

# LEVELr™ ELEVATOR INTERIORS

## INSTALLATION INSTRUCTIONS

### INCLUDED

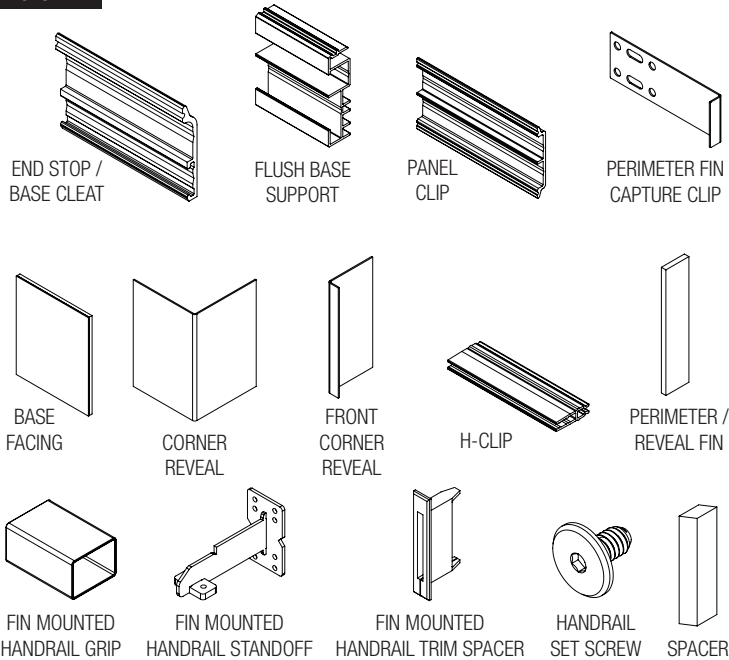

### TOOLS NEEDED

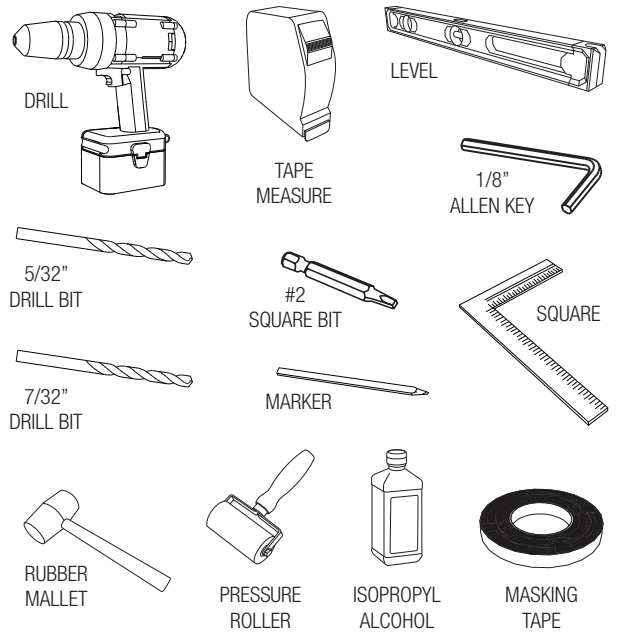

### STEP BY STEP

LEVELr-201A configuration with Flush Base, Reveal Fins, and Fin Mounted Handrail are represented in these instructions. Alternate configurations and trim options will follow a similar installation methodology; as noted, see related instructions on pages 5-8. Please contact your project manager with questions.

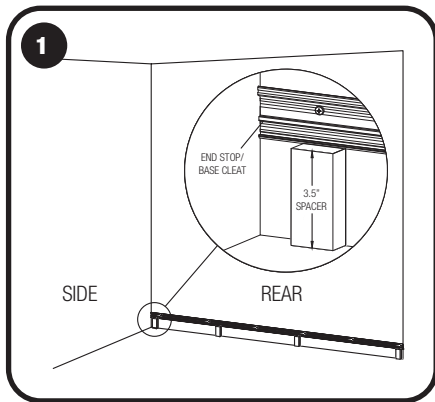

#### Install Horizontal End Stop / Base Cleat.

- Start installation in back left corner, use the supplied MDF spacers for correct spacing from floor.
- Using the top screw chase on the extrusion, secure to wall with screws every 12-18".

**Note:** For LED REVEALS, see related instructions on pages 7-8.

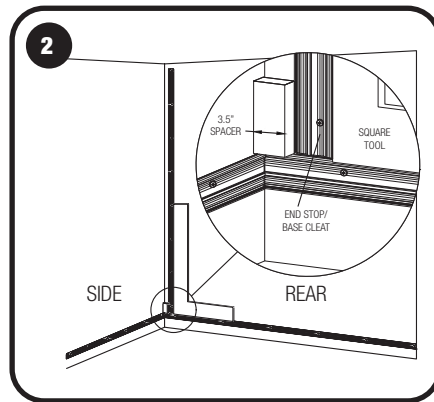

#### Install Vertical End Stop / Base Cleat.

- Use supplied MDF spacer to offset the vertical extrusion from the lower left shell corner.
- Use square tool to ensure perpendicular placement. Precise perpendicular installation is required to maintain the tight system tolerances.
- Secure to wall with screws every 12-18".

**Note:** Vertical End Stop / Base Cleats will have pre-applied Dual-Lock tabs for application.

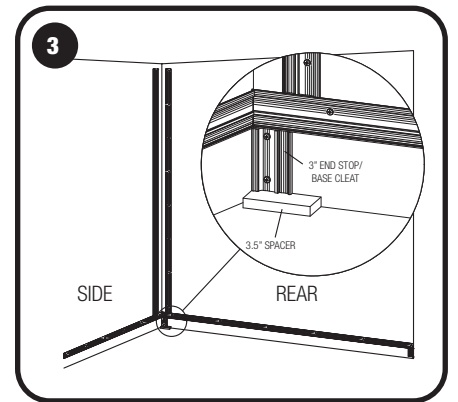

#### Install 3" End Stop / Base Cleats.

- Use supplied MDF spacer for correct spacing from floor.
- Slide 3" extrusion tightly into back corners.
- Secure to wall with screws.

**Note:** 3" End Stop / Base Cleats will have pre-applied Dual-Lock tabs for application.

# LEVELr™ ELEVATOR INTERIORS

## INSTALLATION INSTRUCTIONS

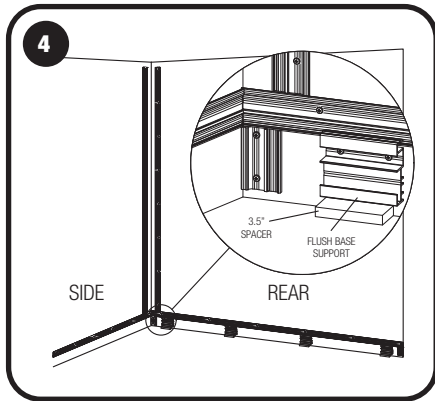

### Install Flush Base Supports.

- Hook Base Supports to the bottom edge of End Stop / Base Cleat, spacing as per drawings, and secure to wall with screws.
- VHB is pre-applied for later use, do not peel.

**Note:** For COVE BASE & LED COVE BASE, see related instructions on pages 5-6.

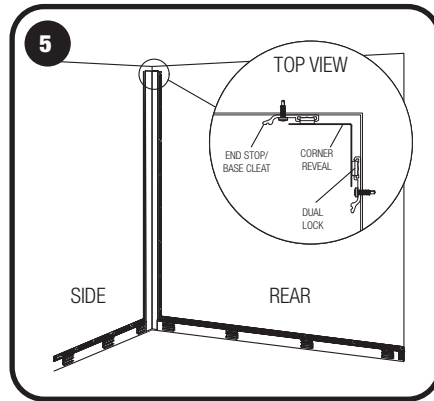

### Install Corner Reveal.

- For best adhesion, clean backside of Corner Reveal using 70% isopropyl alcohol.
- Peel backer from Dual-lock tabs.
- Use supplied MDF spacer for correct spacing from floor; rest Corner Reveal on spacer and carefully center and apply pressure to adhere Corner Reveal to Dual-lock tabs.

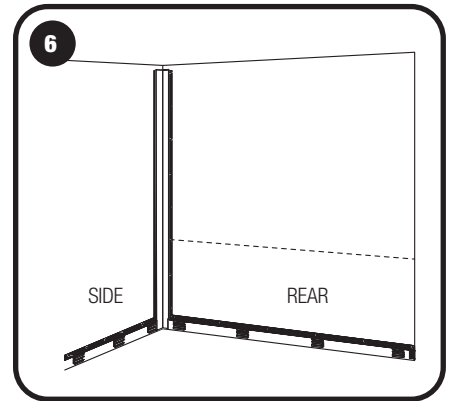

### Draw Handrail Registration Line.

- Identify wall requiring Fin Mounted handrails, refer to drawings and scribe registration lines.

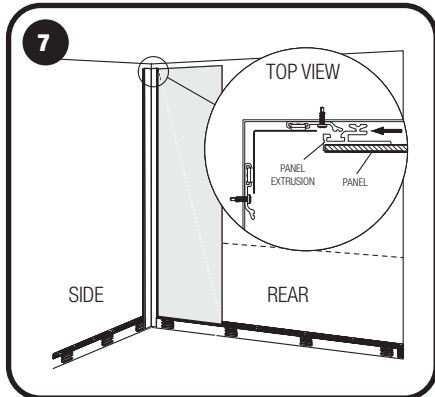

### Install First Panel in sequence.

- Start with the first panel in sequence (usually the bottom left back wall panel).
- Rest panel on Horizontal End Stop / Base Cleat
- Tuck panel tightly into Vertical End Stop / Base Cleat ensuring that the panel is positioned in front of Corner Reveal.

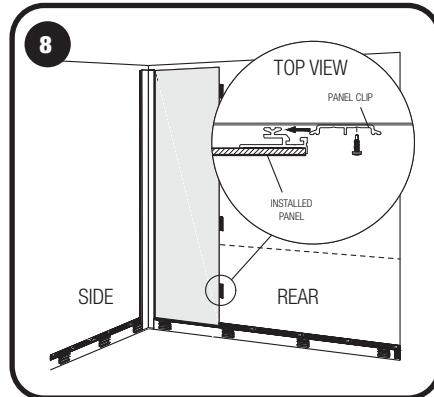

### Attach side Panel Clips.

- Secure side of panel using Panel Clips every 12-18" (avoiding Handrail Registration Line).

**Note:** For LED REVEALS, see related instructions on pages 7-8.

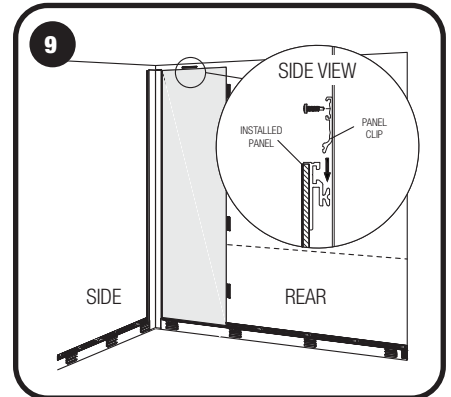

### Attach top Panel Clips.

- Secure top of panel using 1-2 Panel Clips depending on width of panel.

# LEVELr™ ELEVATOR INTERIORS

## INSTALLATION INSTRUCTIONS

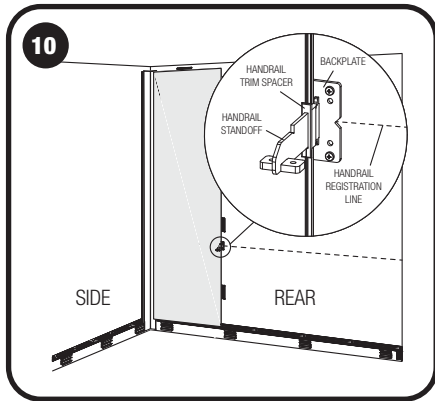

### Install Fin Mounted Handrail Standoff.

- Ensure Handrail Trim Spacer is in place - this will center the standoff in the reveal.
- Align v-notch with Handrail Registration Line.
- Position backplate behind the panel and tightly to panel edge. Secure backplate with screws.
- Install additional Panel Clips directly above and below backplate.
- Remove Handrail Trim Spacer.

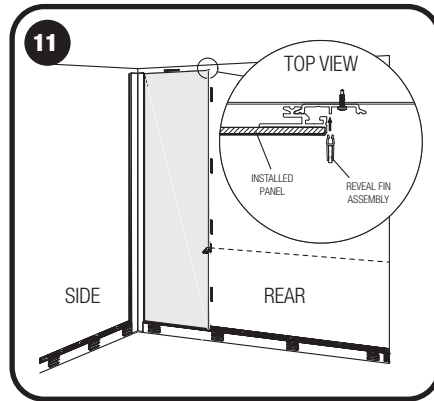

### Install Reveal Fin Assembly to Panel Clips.

- Build Reveal Fin Assemblies by pairing Reveal Fins and H-Clips of matching lengths.
- Refer to drawings and attach Reveal Fin Assemblies to center spine of Panel Clips.
- Reveal Fins will be coplanar with Handrail Standoff

**Note:** Reveal Fin Assembly will not sit flat if Reveal Fin is not fully inserted into H-Clip.

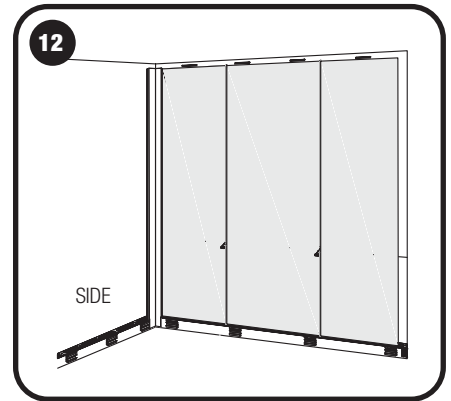

### Repeat steps 6-10 as required.

- Continue installing panels, reveals, and Handrail standoffs as required, refer to drawings for sequence.

**Note:** Panels must tightly “sandwich” the H-Clip to provide a consistent reveal.

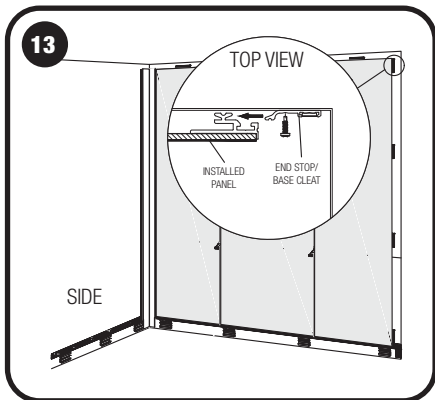

### Install Vertical End Stop / Base Cleats.

- Secure side of last panel using vertical End Stop / Base Cleats with pre-applied Dual-Lock.
- Dual-Lock is pre-applied for later use; do not peel until installing Corner Reveal.

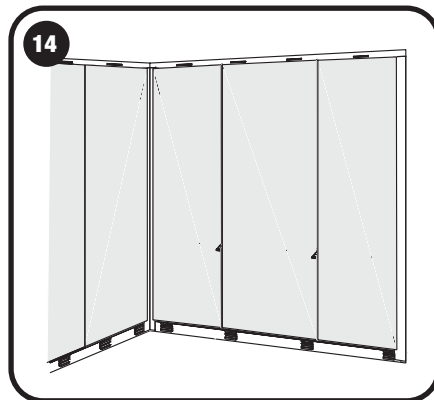

### Repeat instructions for side walls.

- Refer to drawings for sequence and install accordingly using these instructions.

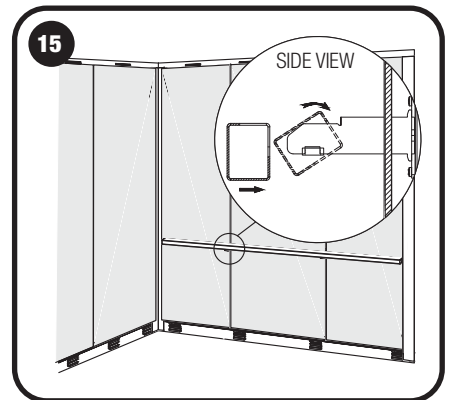

### Install Handrail Grip.

- Slide Handrail Grip onto Standoff with straight slots positioned upward.
- Rotate toward back wall until slot contacts the indent on the Handrail Support.

# LEVELr™ ELEVATOR INTERIORS

## INSTALLATION INSTRUCTIONS

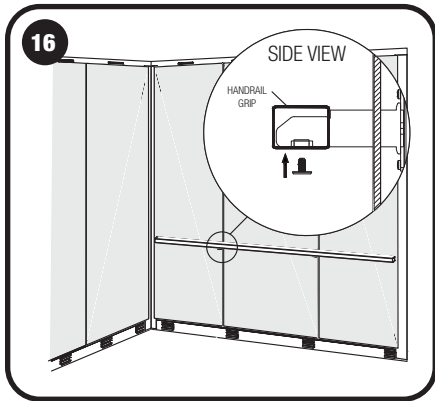

### Install set screw to secure Handrail Grip.

- Once positioned, secure Handrail Grip with provided set screws.

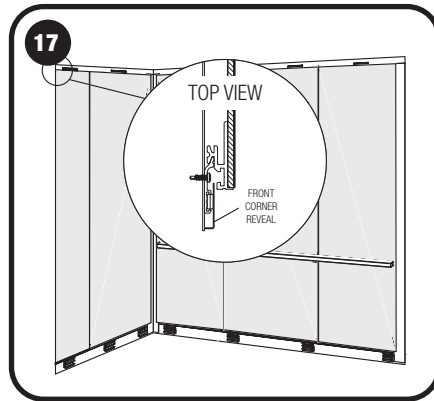

### Install all Front Corner Reveal.

- For best adhesion, clean backside of Front Corner Trim using 70% isopropyl alcohol.
- Peel backer from Dual-lock tabs.
- Use supplied MDF spacer for correct spacing from floor; rest Front Corner Reveal on spacer and carefully position behind panel.
- Apply pressure to adhere Front Corner Reveal to Dual-lock tabs.

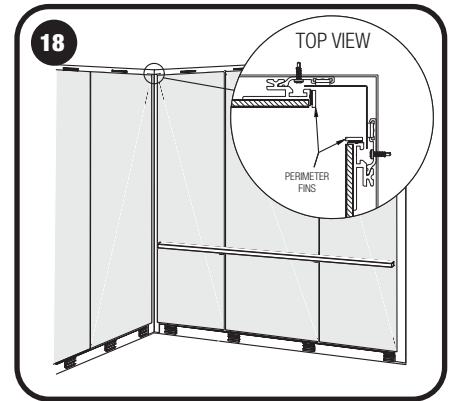

### Install all Perimeter Fins.

- For best adhesion, clean side of panel using 70% isopropyl alcohol.
- Dog-ear pre-applied VHB backer on Perimeter Fins to create a “pull tab”.
- Starting in the corner, use supplied MDF spacer for correct spacing from floor; position Perimeter Fin so front edge is flush with panel.
- Once in place, fully remove VHB backer and apply pressure to adhere Front Corner Trim.

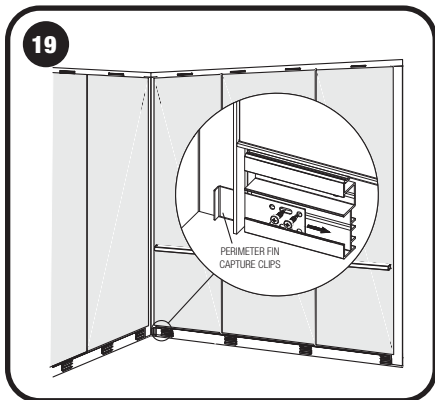

### Install Perimeter Fin Capture Clips.

- Install Perimeter Fin Capture Clips near the base behind Perimeter Fin.
- Slide Capture Clip until tab hugs Perimeter Fin and screw into place with oblong slot.
- Lock into place with additional screw and repeat for all corners.

**Note:** For COVE BASE & LED COVE BASE, see related instructions on pages 5-6.

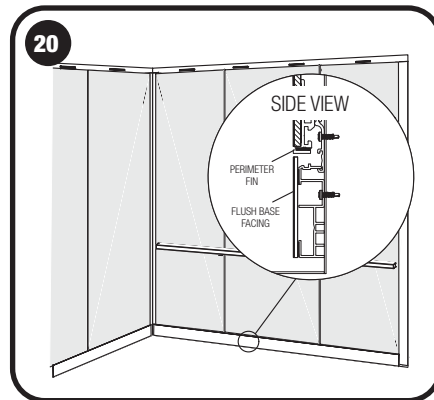

### Install Flush Base Facing.

- Use supplied MDF spacer for correct spacing from floor; dry-fit Base Facing by centering between Perimeter Fins.
- For best adhesion, clean backside of Base Facing using 70% isopropyl alcohol.
- Peel VHB backer from Base Supports and gently apply Base Facing by using light pressure to adhere.

**Note:** Do not install Perimeter Fins above top panels. This area is out of view once ceiling is installed.

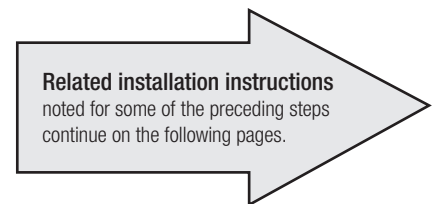

**Related installation instructions**  
noted for some of the preceding steps  
continue on the following pages.

# LEVELr™ ELEVATOR INTERIORS

INSTALLATION INSTRUCTIONS

## COVE BASE

### ALTERNATE COMPONENTS (INCLUDED)

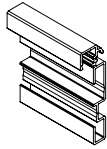

COVE BASE SUPPORT

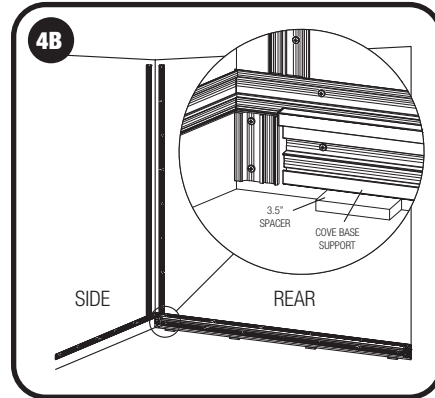

#### Install Cove Base Supports.

- Hook Base Supports to the bottom edge of End Stop / Base Cleat, spacing as per drawings, and secure to wall with screws.
- VHB is pre-applied for later use, do not peel.

**Note:** Continue instructions in step 5 (page 2).

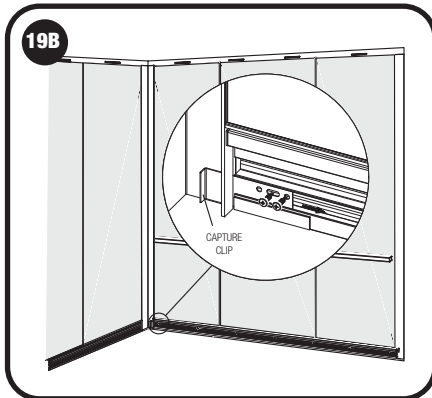

#### Install Perimeter Fin Capture Clips.

- Install Perimeter Fin Capture Clips near the base behind Perimeter Fin.
- Slide Capture Clip until tab hugs Perimeter Fin and screw into place with oblong slot.
- Lock into place with additional screw and repeat for all corners.

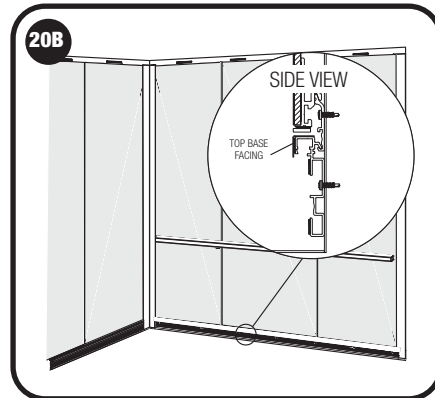

#### Install top portion of Cove Base.

- Dry-fit top portion of Cove Base by centering between Perimeter Fins
- For best adhesion, clean backside of Facing using 70% isopropyl alcohol.
- Peel VHB backer from top portion of Base Supports and gently apply Top Base Facing by using light pressure to adhere.

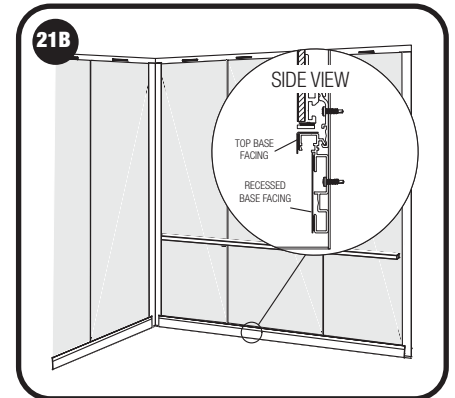

#### Install Base Facing to Cove Base Support.

- Dry-fit recessed portion of Cove Base by centering between Perimeter Fins
- For best adhesion, clean backside of Facing using 70% isopropyl alcohol.
- Peel VHB backer from recessed portion of Base Supports and gently apply Recessed Base Facing by using light pressure to adhere.

**Note:** Cove Base install complete.

# LEVELr™ ELEVATOR INTERIORS

## INSTALLATION INSTRUCTIONS

### LED COVE BASE

#### ALTERNATE COMPONENTS (INCLUDED)

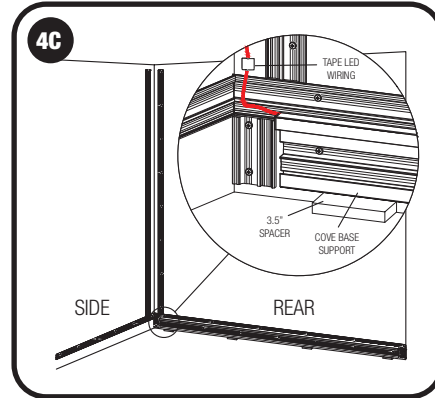
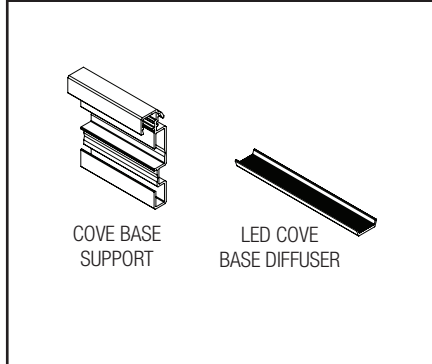

#### Install Cove Base Supports.

- Hook Base Supports to the bottom edge of End Stop / Base Cleat, spacing as per drawings, and secure to wall with screws.
- VHB is pre-applied for later use, do not peel.
- Secure LED wiring to cab shell with tape (once installed, Corner Trim will conceal LED wiring).

**Note:** Continue instructions in step 5 (page 2).

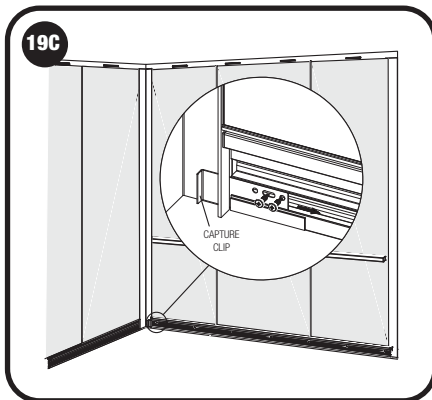

#### Install Perimeter Fin Capture Clips.

- Install Perimeter Fin Capture Clips near the base behind Perimeter Fin.
- Slide Capture Clip until tab hugs Perimeter Fin and screw into place with oblong slot.
- Lock into place with additional screw and repeat for all corners.

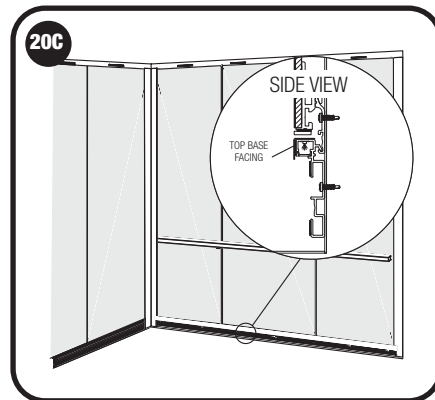

#### Install top portion of Cove Base facing.

- Dry-fit top portion of Cove Base by centering between Perimeter Fins
- For best adhesion, clean backside of Facing using 70% isopropyl alcohol.
- Peel VHB backer from top portion of Base Supports and gently apply Top Base Facing by using light pressure to adhere.

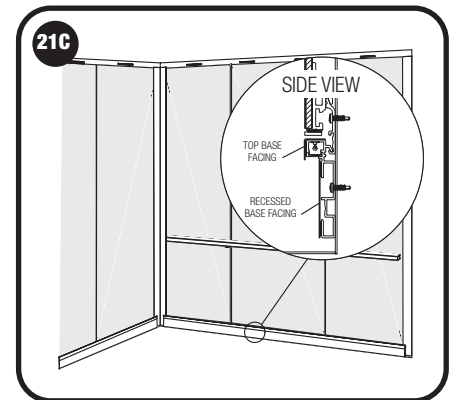

#### Install recessed portion of Cove Base facing.

- Dry-fit recessed portion of Cove Base by centering between Perimeter Fins
- For best adhesion, clean backside of Facing using 70% isopropyl alcohol.
- Peel VHB backer from recessed portion of Base Supports and gently apply Recessed Base Facing by using light pressure to adhere.

**Note:** LED Cove Base install complete.

# LEVELr™ ELEVATOR INTERIORS

## INSTALLATION INSTRUCTIONS

### LED REVEALS

#### ALTERNATE COMPONENTS (INCLUDED)

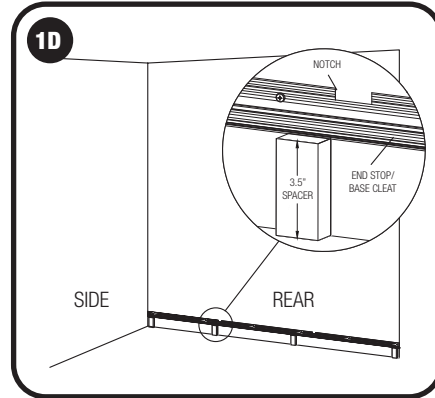
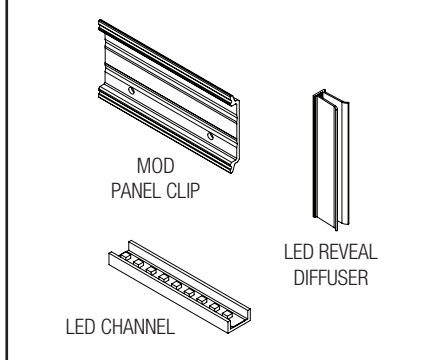

#### Install Horizontal End Stop / Base Cleat.

- Start installation in back left corner, use the supplied MDF spacers for correct spacing from floor.
- Using the top screw chase on the extrusion, Secure to wall with screws every 12-18".

**Note:** Continue instructions in step 2 (page 1).

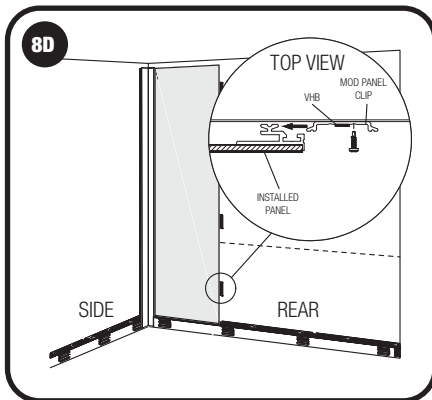

#### Attach side modified Panel Clips.

- Secure side of panel using Panel Clips every 12-18" (avoiding Handrail Registration Line).

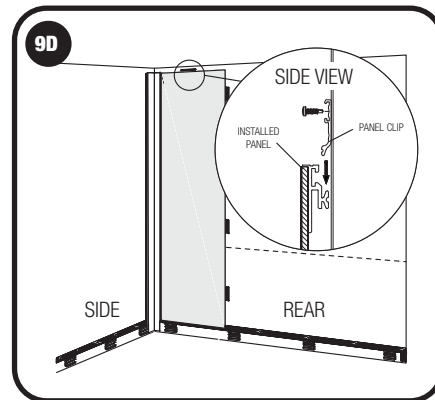

#### Attach top Panel Clips.

- Secure top of panel using 1-2 Panel Clips depending on width of panel.

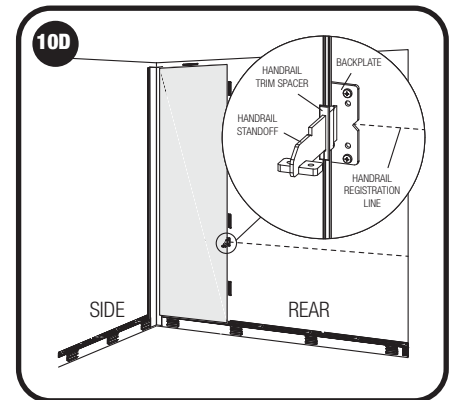

#### Install Fin-mounted Handrail Standoff.

- Ensure Handrail Trim Spacer is in place - this will center the standoff in the reveal.
- Align v-notch with Handrail Registration Line.
- Position backplate behind the panel and tightly to panel edge. Secure backplate with screws.
- Install additional Panel Clips directly above and below backplate.
- Do not remove Handrail Trim Spacer.

# LEVELr™ ELEVATOR INTERIORS

## INSTALLATION INSTRUCTIONS

### LED REVEALS (CONTINUED)

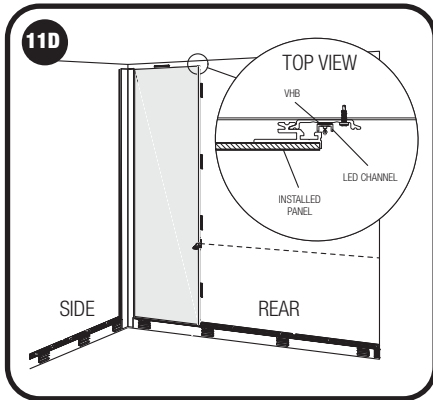

#### Install LED Reveal Assembly to Panel Clips.

- LED Reveal Assembly arrives pre-assembled. For best adhesion, clean backside of LED Channel using 70% isopropyl alcohol.
- Dog-ear pre-applied VHB backer on Panel Clips to create a “pull tab”.
- Starting below Handrail, position LED Reveal Assembly tightly to underside of Handrail Trim Spacer and along groove in panel edge.
- Once in place, fully remove VHB backer and apply pressure to adhere.
- LED wiring will always exit upward. Secure to cab shell with tape.

**Note:** if no handrails, register LED Reveal Assembly with bottom of adjacent panel.

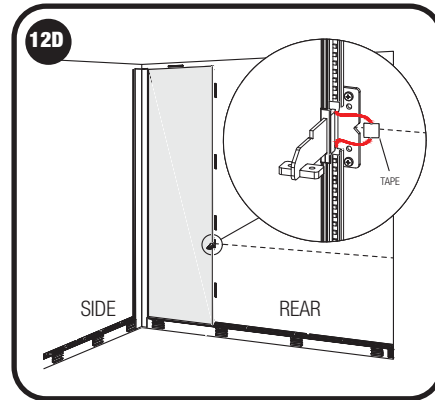

#### Position and tape LED wiring.

- Above Handrail, position LED Reveal Assembly tightly to top of Handrail Trim Spacer and along groove in panel edge.
- Once in place, fully remove VHB backer and apply pressure to adhere.
- LED wiring will always exit upward. Secure to cab shell with tape.

**Note:** Continue instructions in step 13 (page 3).

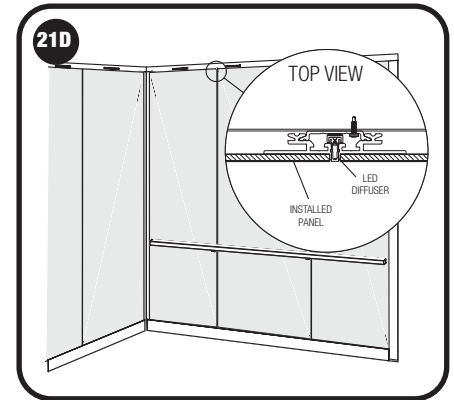

#### Install LED Diffuser.

- Diffuser rests on panel edge, slightly recessed from panel face. Do not insert fully.
- In locations around Handrail Standoff, install and slide the Diffuser into position just behind Handrail Trim Spacer.

**Note:** LED Reveals install complete.



# LEVELr™ ELEVATOR INTERIORS

## RECESSED REVEALS

### ALTERNATE COMPONENTS (INCLUDED)

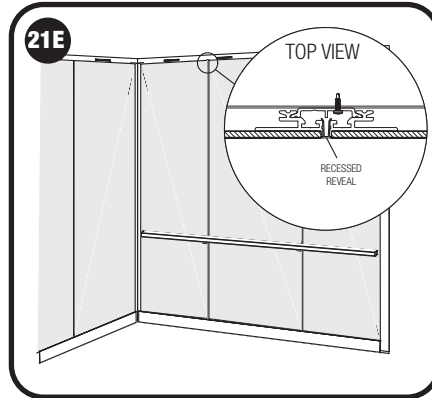
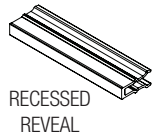

#### Install Recessed Reveals.

- Recessed Reveal rests on panel edge, slightly recessed from panel face. Do not insert fully.
- In locations around Handrail Standoff, install and slide the Recessed Reveal into position just behind Handrail Trim Spacer.

**Note:** Recessed Reveals install complete.