

TRANSIT™ SEATING

SURFACE MOUNT INSTALLATION INSTRUCTIONS

MOUNTING KIT (SOLD SEPARATELY)



5/16" hex bit



7/32" hex bit for tamper-resistant bolts

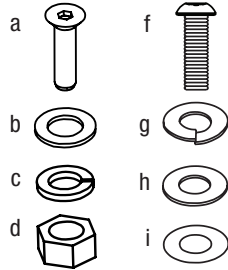

TOOLS NEEDED



pencil

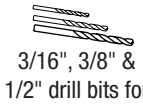

3/16", 3/8" & 1/2" drill bits for concrete

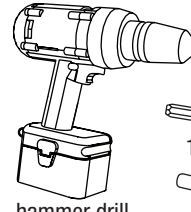

hammer drill

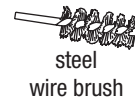

steel wire brush

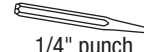

1/4" punch



3/4" Wrench



LOCTITE® 243™ thread locker

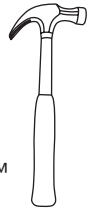

hammer

STEP BY STEP FOR ALL SURFACE MOUNTED TRANSIT SEATING (SBTRA-1BA SHOWN)

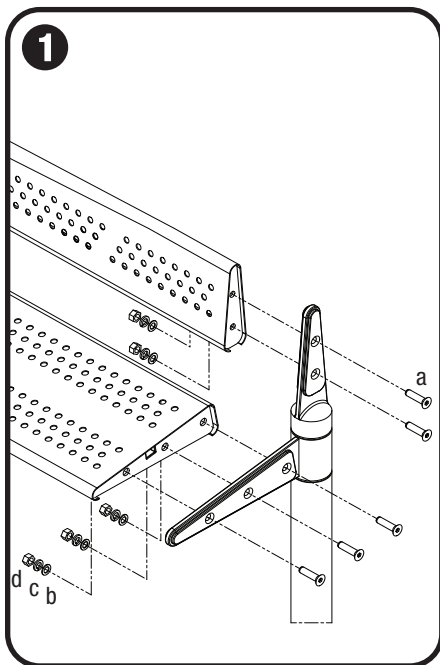

Attach bench seat (and back if required)

- Position bench back against leg as shown first (if required).
- Install 1/2"-13 x 2" socket head cap bolt (a) through leg and bench back. Slide 1/2" stainless steel flat washer (b) then 1/2" stainless steel lock washer (c) onto bolt.
- Apply LOCTITE® 243™ thread locker or similar to fastener threads then thread 1/2"-13 stainless steel hex nut (d) onto bolt.
- Tighten nut securely using 5/16" hex bit and ratchet and 3/4" wrench.
- Repeat process for fasteners in bench seat.

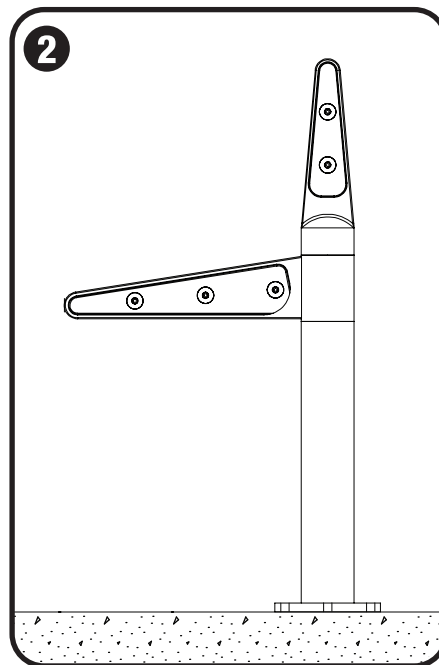

Mark hole locations

- Place bench in desired location. Mark center of each hole location with a pencil.
- NOTE: Bench is not freestanding and must be supported during this step.

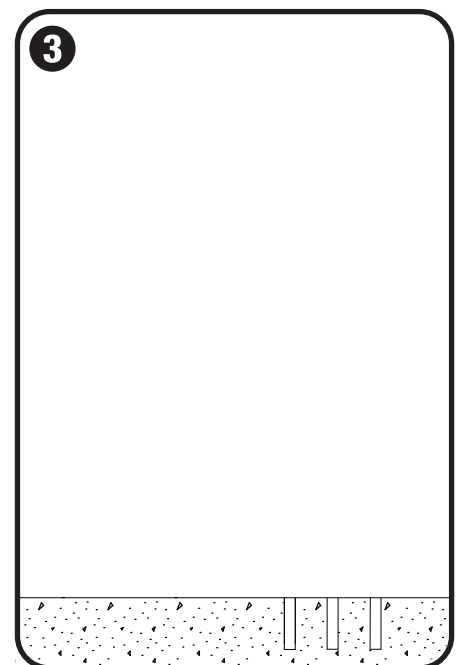

Drill holes

- Use hammer drill to drill 1-7/8" deep x 1/2" diameter anchor hole at each marked location using a 1/2" drill bit suitable for concrete drilling.
- NOTE: Forms+Surfaces recommends starting holes with 3/16" diameter drill bit followed by 3/8" and finally 1/2" for maximum accuracy.

TRANSIT™ SEATING

SURFACE MOUNT INSTALLATION INSTRUCTIONS

STEP BY STEP FOR ALL SURFACE MOUNTED TRANSIT SEATING (SBTRA-1BA SHOWN)

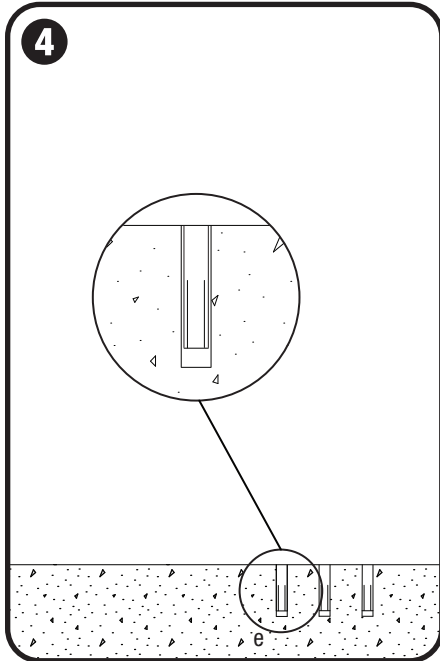

Insert & set anchors

- Use compressed air and steel wire brush to clean each anchor hole.
- Insert 3/8"-16 x 1-1/2" anchor (e) into each anchor hole and use hammer to tap anchor tops flush with ground level.
- Use 1/4" punch and hammer to set anchors by driving down the center of each anchor until it stops.

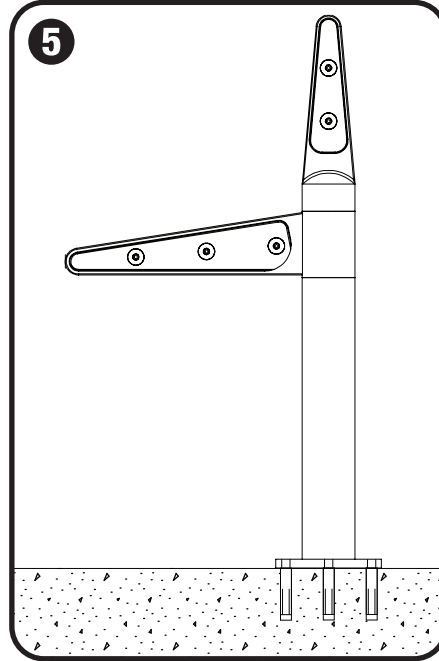

Position bench

- Position bench so that mounting holes line up with anchors.

NOTE: Bench is not freestanding and must be supported until steps 5 and 6 are complete.

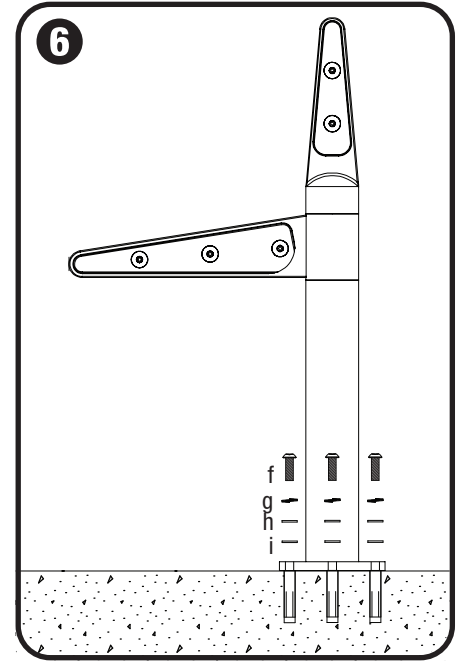

Attach bench

- Slide 3/8" stainless steel lock washer (g), then 3/8" stainless steel flat washer (h) and 3/8" nylon flat washer (i) onto each 3/8"-16 x 1" tamper-resistant button head cap bolt (f).
- Insert bolts into mounting holes in bench and thread into anchors using 7/32" hex bit for tamper-resistant screws.

TRANSIT™ SEATING

SURFACE MOUNT INSTALLATION INSTRUCTIONS

STEP BY STEP FOR ALL SURFACE MOUNTED TRANSIT SEATING (SBTRA-1BA SHOWN)

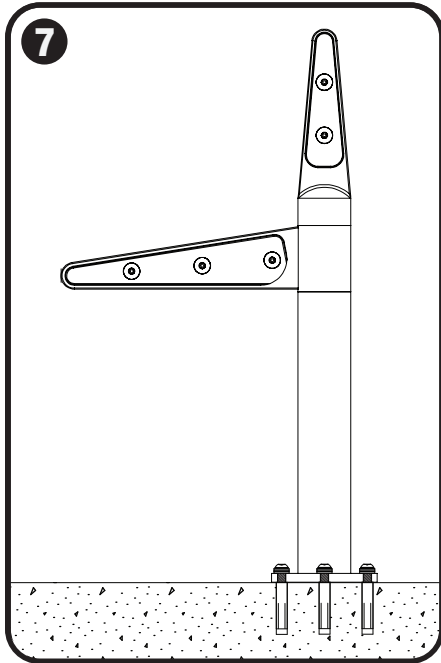

Tighten bolts

- Tighten bolts until snug.