

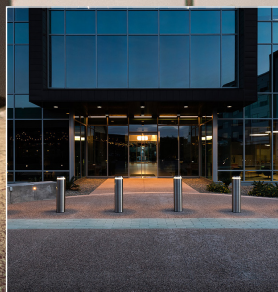

HELIO™ M30/K4 SECURITY BOLLARD

PRODUCT DATA

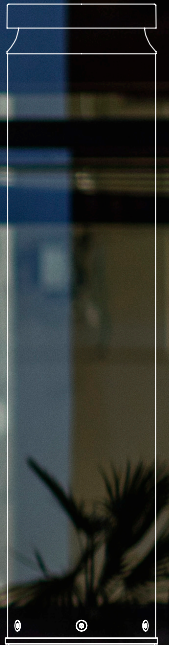



HELIO™ M30/K4 SECURITY BOLLARD

PRODUCT DATA

Helio M30/K4 Security Bollards offer robust protection for public spaces of all kinds. Simply elegant in stainless steel, fixtures 9.25" in diameter have an embedded security core and are available in illuminated and non-illuminated designs. Illuminated bollards feature a frosted acrylic lens, 180° or 360° light distribution, and Cree® LEDs in 3000K warm white and 4000K neutral white. Bollards provide downward-facing light to help minimize light pollution and glare. For expanded performance, coordinating 6" diameter Helio Bollards in illuminated, non-illuminated and security core variations are also available.

MATERIAL & CONSTRUCTION DETAILS

| CONFIGURATIONS | LED LAMPS & DRIVER | INSTALLATION |
|---|--|---|
| <ul style="list-style-type: none"> Bollard dimensions are 40" high x 9.25" diameter. 180° and 360° light distribution options are available. To complement illuminated bollards, a non-illuminated version is also available. A Series 900 Helio Bollard without security core is available (illuminated or non-illuminated). | <ul style="list-style-type: none"> Custom LED light engine with Cree® LEDs. 3000K warm white and 4000K neutral white color temperatures. Less than 5% upward lumen output. LED driver input voltage is 120-277VAC, -30°C minimum starting temperature. 40W driver has reverse-phase, forward-phase, and 0-10V dimming capabilities. LED driver certifications include: IP64 enclosure and Class 2 rated output (UL8750). | <ul style="list-style-type: none"> Security bollards have an embedded security core. Non-security bollards are surface mounted with J-bolts. Installation of a surge protector as part of each unit's wiring is recommended. Necessary hardware is included for all mounting options. Templates are available upon request. |
| MATERIALS & FINISHES | | MAINTENANCE |
| <ul style="list-style-type: none"> Illuminated bollards have a tubular stainless steel column, frosted acrylic lens, and a stainless steel head cap. Non-illuminated bollards are tubular stainless steel with welded stainless steel cap. Standard stainless steel finish is Satin. For optional powdercoat colors see the Forms+Surfaces Powdercoat Chart. Custom RAL colors are available for an upcharge. | <ul style="list-style-type: none"> Metal surfaces can be cleaned as needed using a soft cloth or brush with warm water and a mild detergent. Avoid abrasive cleaners. | |

M30-P1/K4 SECURITY CORE

Site security is a major concern in today's unpredictable world. Public and private buildings, government facilities, campuses and public parks are all susceptible to accidental, as well as deliberate, vehicle infringement. Design professionals, city planners, facilities managers and engineers must now be increasingly sensitive to the safety and security requirements of public and private spaces. Security bollards placed at ingress points are an excellent way to guard against vehicle infringement while allowing pedestrian access.

Most security bollards have taken the form of generic pipes and cylinders that offered little in the way of design or lighting functionality. Forms+Surfaces' Helio M30-P1/K4 Security Bollards bring a pre-engineered and fully-tested security core to our Helio line to offer a beautiful and efficient lighting bollard that also meets the stringent high-impact crash requirements normally attained only with unattractive pipe barriers.

Forms+Surfaces' security bollards have been tested using a Finite Element Analysis (FEA) by a professional engineering consultant. FEA is a software-based tool commonly used in the automotive industry and used extensively for crash test simulations. All of our bollards with the security solution option were tested and passed a very demanding set of impact criteria. Tests were performed using a bollard set in permanent concrete footings and struck by a vehicle at a 90-degree impact. The impact simulation found the bollards to be successful in stopping a 15,000 lb. vehicle traveling at a minimum test velocity of 30 mph in less than 3.3 feet (1 meter).

Our permanently embedded security cores are available for both illuminated and non-illuminated bollards. Please contact us to discuss design and installation considerations for Helio bollards with security cores.

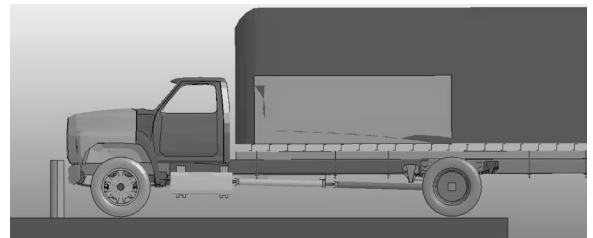

Crash scenario with 15,000 lb pickup truck approaching embedded bollard system at 30 mph

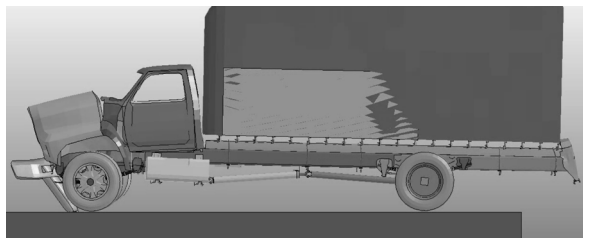

Full-scale crash immediately after impact



HELIO™ M30/K4 SECURITY BOLLARD

PRODUCT DATA

NOMINAL DIMENSIONS - EMBEDDED M30/K4 SECURITY CORE

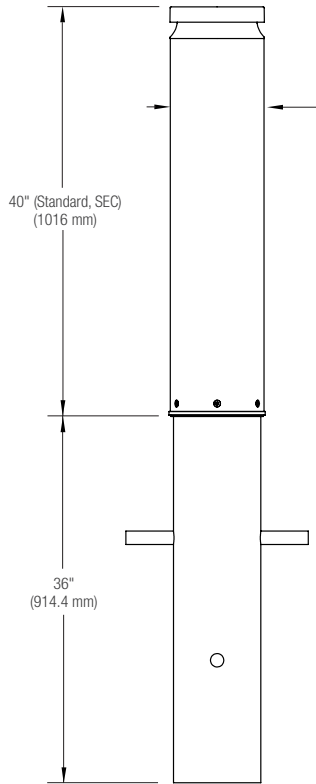

NOMINAL DIMENSIONS - SURFACE MOUNT WITH J-BOLTS

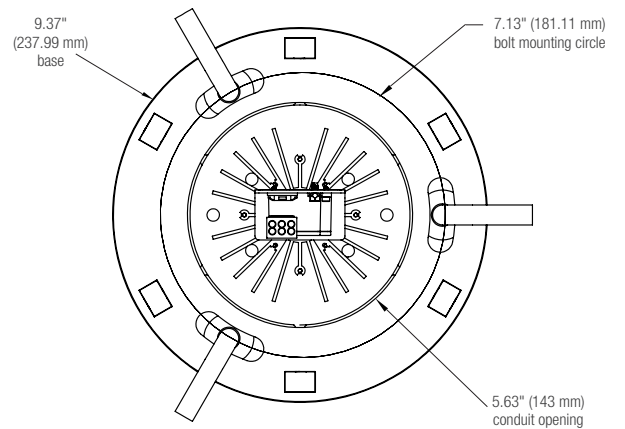
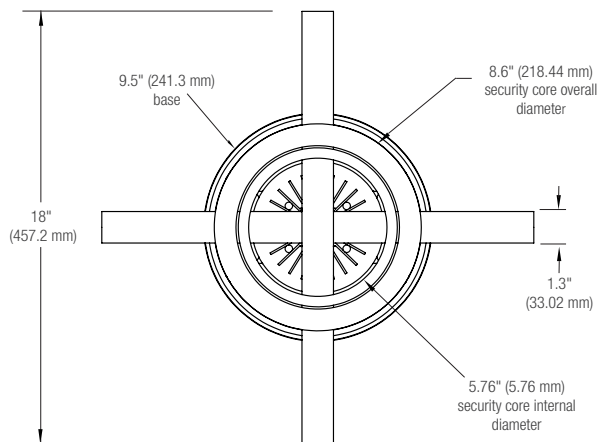
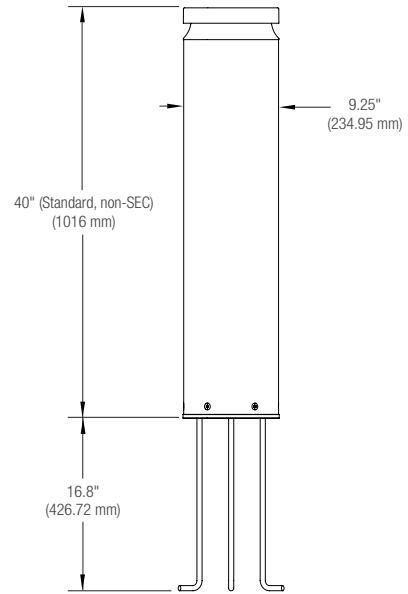



HELIO™ M30/K4 SECURITY BOLLARD

PRODUCT DATA

LIGHT ENGINE DESCRIPTION

| LED ENGINE | DESCRIPTION | COLOR TEMPERATURE | STARTING TEMPERATURE °C |
|------------|-------------|-------------------|-------------------------|
| 3000K LED | 40W | 3000K | -30 |
| 4000K LED | 40W | 4000K | -30 |

CERTIFICATION

- ETL and C-ETL listed for wet locations.

ENVIRONMENTAL CONSIDERATIONS

- Please refer to the Helio M30/K4 Security Bollard Environmental Data Sheets for detailed environmental impact information.
- Metal components have a long life cycle and are 100% recyclable.
- Standard powdercoat finishes are no-VOC; non-standard powdercoat finishes are no- or low-VOC, depending on color.
- Low maintenance.

MODEL NUMBERS AND DESCRIPTIONS

| MODEL | DESCRIPTION |
|----------------|--|
| LBLHO-903-SEC | Helio M30/K4 Security Bollard, Series 900, illuminated |
| LBLHO-903-NSEC | Helio M30/K4 Security Bollard, Series 900, non-illuminated |
| LBLHO-903 | Helio Bollard, Series 900, illuminated (non-security) |
| LBLHO-903-N | Helio Bollard, Series 900, non-illuminated (non-security) |

PRODUCT OPTIONS

The following options are available for an upcharge

| | |
|---|-----------------------------|
| Add powdercoat color from Forms+Surfaces Powdercoat Chart | Custom RAL powdercoat color |
|---|-----------------------------|

LEAD TIME: 6 to 8 weeks. Shorter lead times may be available upon request. Please contact us to discuss your specific timing requirements.

PRICING: Please contact us at **800.451.0410** or **sales@forms-surfaces.com**. At Forms+Surfaces, we design, manufacture and sell our products directly to you. Our sales team is available to assist you with questions about our products, requests for quotes, and orders. Territory Managers are located worldwide to assist with the front-end specification and quoting process, and our in-house Project Sales Coordinators follow your project through from the time you place an order to shipment.

TO ORDER SPECIFY: Quantity, finish, color temperature, and light distribution option. Quote/Order Forms are available on our website to lead you through the specification process in a simple checkbox format.