

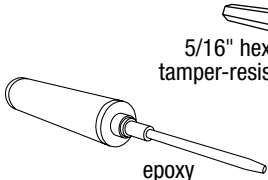

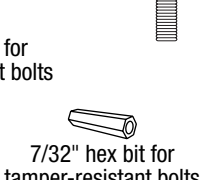



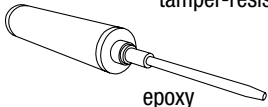

TANGENT™ RAIL SEATING

SURFACE MOUNT INSTALLATION INSTRUCTIONS

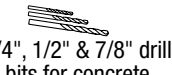
MOUNTING KIT (SOLD SEPARATELY)		TOOLS NEEDED	
 <p>5/16" hex bit for tamper-resistant bolts</p>	 <p>7/32" hex bit for tamper-resistant bolts</p>	 <p>pencil</p>	 <p>hand-ratchet</p>
 <p>epoxy</p>	 <p>hammer drill</p>	 <p>1/4", 1/2" & 7/8" drill bits for concrete</p>	 <p>steel wire brush</p>
 <p>loctite</p>	 <p>epoxy gun</p>		

STEP BY STEP

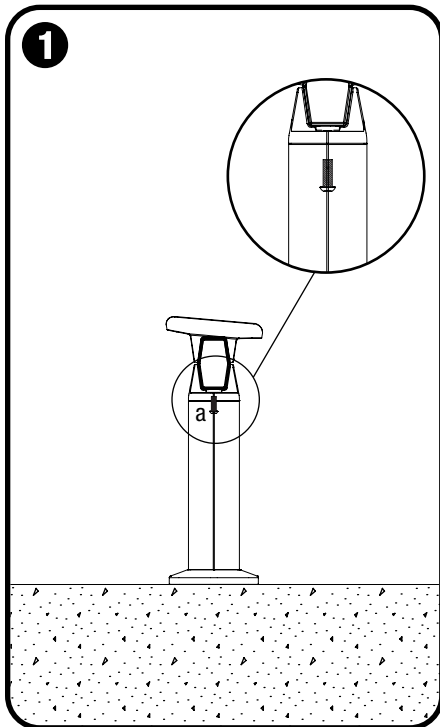

Attach legs to rail

- Line holes in leg connection castings up with holes in rail and insert bolts.
- Thread 3/8"-16 x 1-1/4" button head cap bolts (a) into holes and tighten using a hand-ratchet with a 7/32" hex bit for tamper-resistant bolts.
- When placing rail, note that the back of the leg is indented and the front of the leg is flat.

NOTE: Rail seating is not freestanding and must be supported during this step.

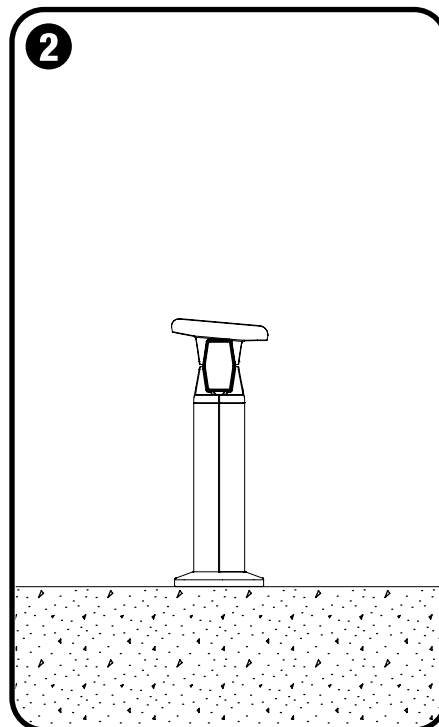

Mark hole locations

- Place rail & legs in desired location. Mark center of each hole location with a pencil.
 - Seat connect bracket is angled downward toward the rear of the bench.
- NOTE: Rail seating is not freestanding and must be supported during this step.

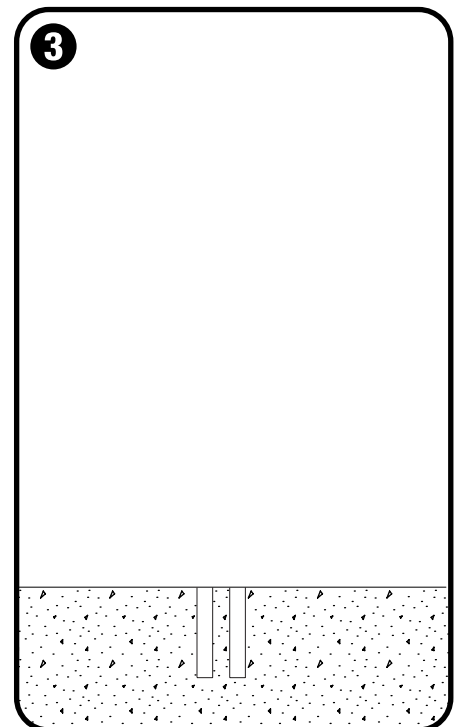

Drill holes

- Use hammer drill to drill 5" deep x 7/8" diameter anchor hole at each marked location using a 7/8" drill bit suitable for concrete drilling.
- NOTE: Forms+Surfaces recommends starting holes with 1/4" diameter drill bit followed by 1/2" and finally 7/8" for maximum accuracy.

TANGENT™ RAIL SEATING

SURFACE MOUNT INSTALLATION INSTRUCTIONS

STEP BY STEP

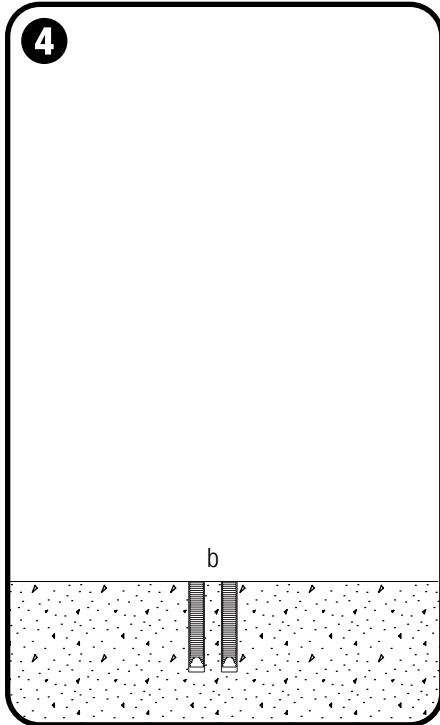

Fill holes & insert anchors

- Use compressed air and steel wire brush to clean each anchor hole in accordance with epoxy instructions.
- Use gun to fill each anchor hole 5/8 of the hole depth in accordance with epoxy instructions.
- Insert 1/2"-13 x 5" epoxy anchor (b) into each anchor hole so anchor top is flush with ground. Allow proper curing time according to cure schedule on epoxy instructions before moving on to the next step.

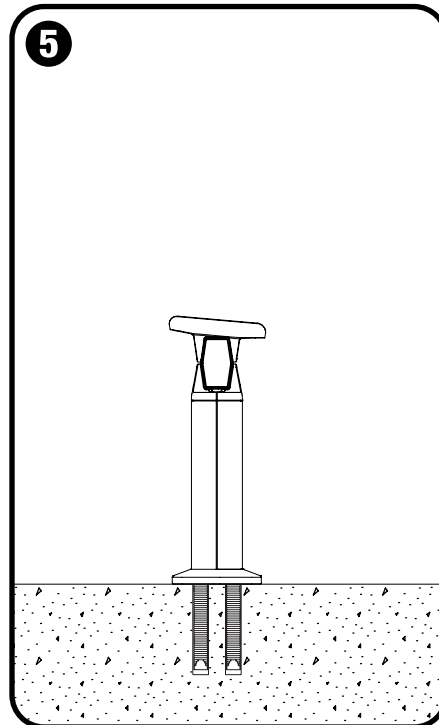

Position rail & legs

- Position rail & legs so that mounting holes line up with anchors.
- NOTE: Rail seating is not freestanding and must be supported during this step.

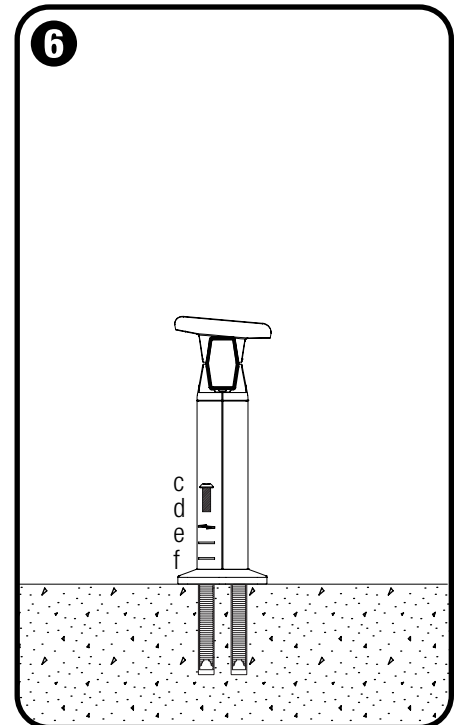

Attach rail & legs

- Slide 1/2" stainless steel lock washer (d), 1/2" stainless steel flat washer (e), and 1/2" nylon flat washer (f) onto each 1/2"-13 x 1-1/2" tamper-resistant button head cap bolt (c).
- Insert bolts into mounting holes in bench and thread into anchors using 5/16" hex bit for tamper-resistant bolts.

TANGENT™ RAIL SEATING

STEP BY STEP

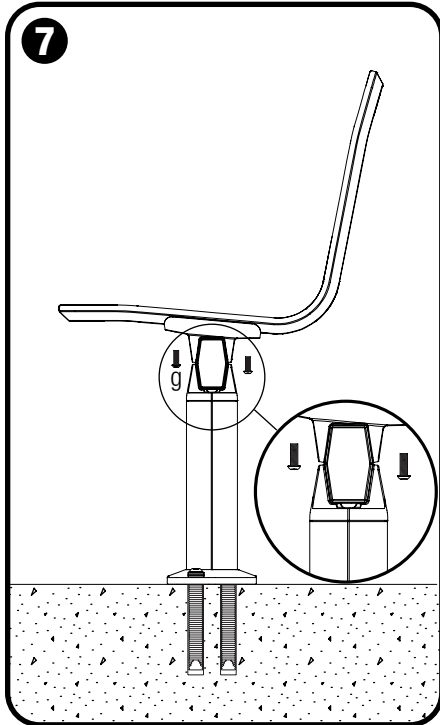

Attach seats & armrests to rail

- Line holes in seats and armrests up with holes in connection castings (already attached to rail) and insert bolts.
- Thread 3/8" - 16 x 3/4" button head cap bolts (g) into holes and tighten using a hand-ratchet with 7/32" hex bit for tamper-resistant bolts.

NOTE: Seats and armrests must be supported during this step until all bolts are tightened.

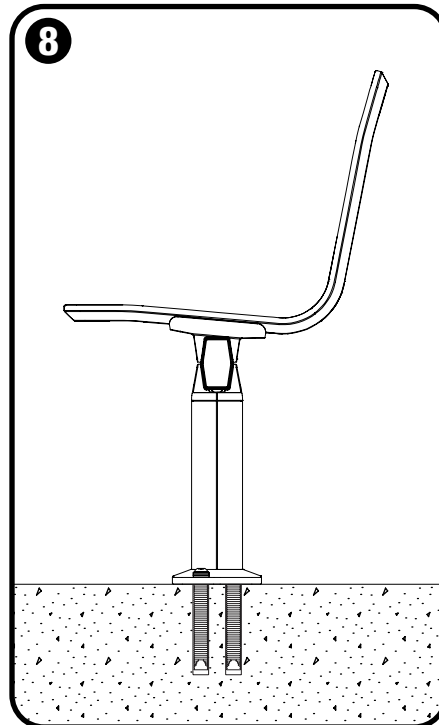

Tighten bolts

- Tighten all bolts with a hand-ratchet until snug.