



OLYMPIA™ BIKE RACK

PRODUCT DATA





OLYMPIA™ BIKE RACK

PRODUCT DATA

The **Olympia Bike Rack's** smooth, fluid curves combined with the strength that comes with solid corrosion-resistant cast aluminum construction make this rack a perfect choice for parks, corporate campuses and more. Its stand-alone, space-saving design allows for an unlimited number of configuration options for ultimate design flexibility.

MATERIAL & FINISHES

MATERIAL	FINISHES
<ul style="list-style-type: none"> Body is made of corrosion-resistant cast aluminum with a powdercoat finish. 	<ul style="list-style-type: none"> See the Forms+Surfaces Powdercoat Chart for details. Custom RAL colors are available for an upcharge. Due to the inherent nature of metal castings, gloss powdercoats are not offered for cast components.

INSTALLATION & MAINTENANCE

GUIDELINES & SECURITY	INSTALLATION	MAINTENANCE
<ul style="list-style-type: none"> Meets Association of Pedestrian and Bicycle Professionals (APBP) guidelines. A locking point detail and mounting configurations that meet APBP guidelines can be found on page 2 of this document. 	<ul style="list-style-type: none"> Olympia Bike Racks must be surface mounted with embedded anchors. Stainless steel anchors and tamper-resistant stainless steel bolts are sold separately. 	<ul style="list-style-type: none"> Metal surfaces can be cleaned as needed using a soft cloth or brush with warm water and a mild detergent. Avoid abrasive cleaners.

NOMINAL DIMENSIONS

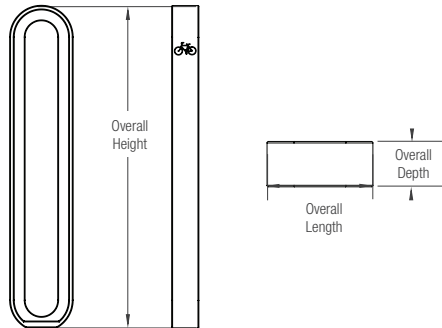

OVERALL LENGTH	OVERALL DEPTH	OVERALL HEIGHT	WEIGHT
7" (178 mm)	3" (76 mm)	35.6" (904 mm)	22.2 lbs (10.1 kg)

LOCKING POINT AND CONFIGURATION EXAMPLES

The Olympia Bike Rack was designed to allow for a multitude of locking point and configuration options to meet your individual needs. Please note that for optimal performance, Forms+Surfaces recommends a 36" center-to-center placement. See diagrams below and the separate installation instructions document for more details.

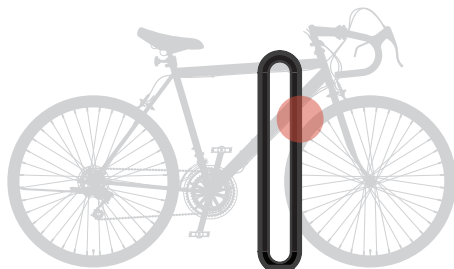

 A standard U-lock can be locked at this location to meet APBP guidelines for security and functionality.

LOCKING POINT EXAMPLE

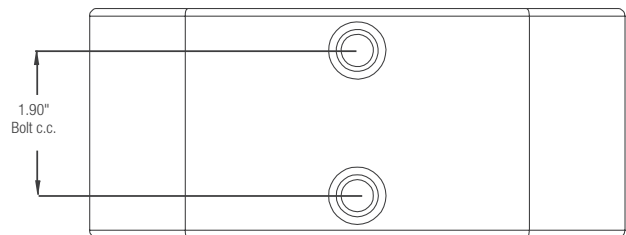

MOUNTING / HARDWARE DETAIL



LOCKING POINT AND CONFIGURATION EXAMPLES (Continued)

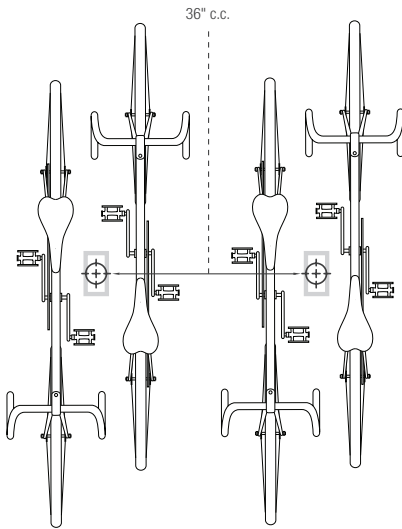

CONFIGURATION EXAMPLE A

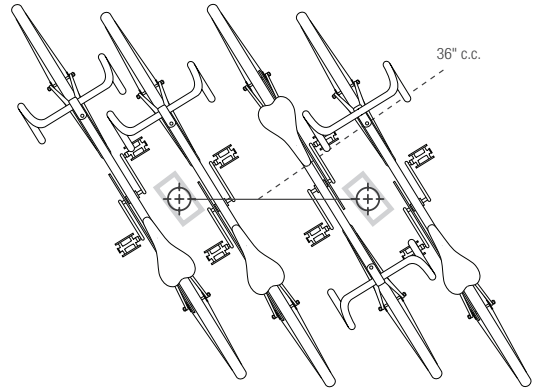

CONFIGURATION EXAMPLE B

ENVIRONMENTAL CONSIDERATIONS

- Please refer to the Olympia Bike Rack Environmental Data Sheet for detailed environmental impact information.
- Olympia's aluminum casting has up to 95% recycled content and is fully recyclable.
- Standard powdercoat finishes are no-VOC; non-standard powdercoat finishes are no- or low-VOC, depending on color.
- Low maintenance.

MODEL NUMBER AND DESCRIPTION

MODEL	DESCRIPTION
SKOLY	Olympia Bike Rack

PRODUCT OPTIONS

The following options are available for an upcharge

Stainless steel anchors and tamper-resistant stainless steel bolts	Custom RAL powdercoat color
--	-----------------------------

LEAD TIME: 4 weeks. Shorter lead times may be available upon request. Please contact us to discuss your specific timing requirements.

PRICING: Please contact us at **800.451.0410** or **sales@forms-surfaces.com**. At Forms+Surfaces, we design, manufacture and sell our products directly to you. Our sales team is available to assist you with questions about our products, requests for quotes, and orders. Territory Managers are located worldwide to assist with the front-end specification and quoting process, and our in-house Project Sales Coordinators follow your project through from the time you place an order to shipment.

TO ORDER SPECIFY: Quantity, model, powdercoat color for body casting. Quote/Order Forms are available on our website to lead you through the specification process in a simple checkbox format.