

BOTTLES & CANS

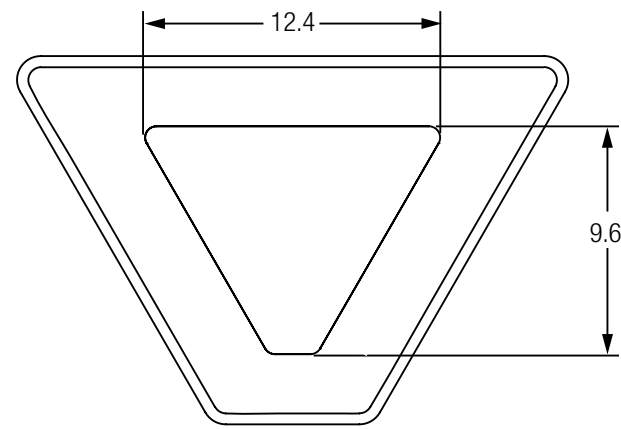

LITTER

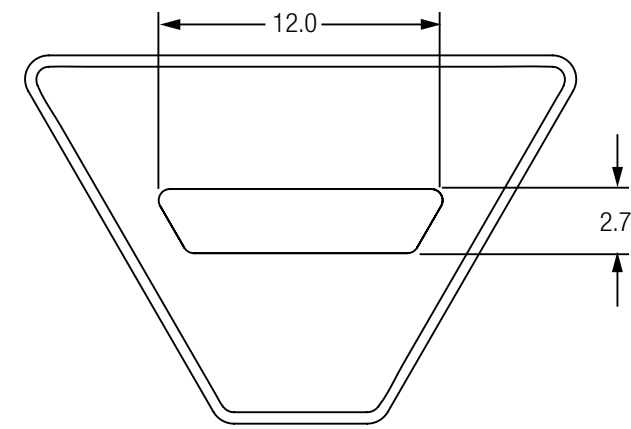

PAPER

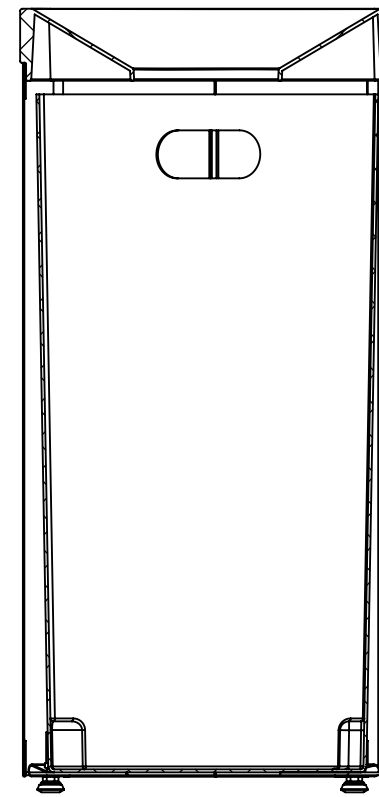
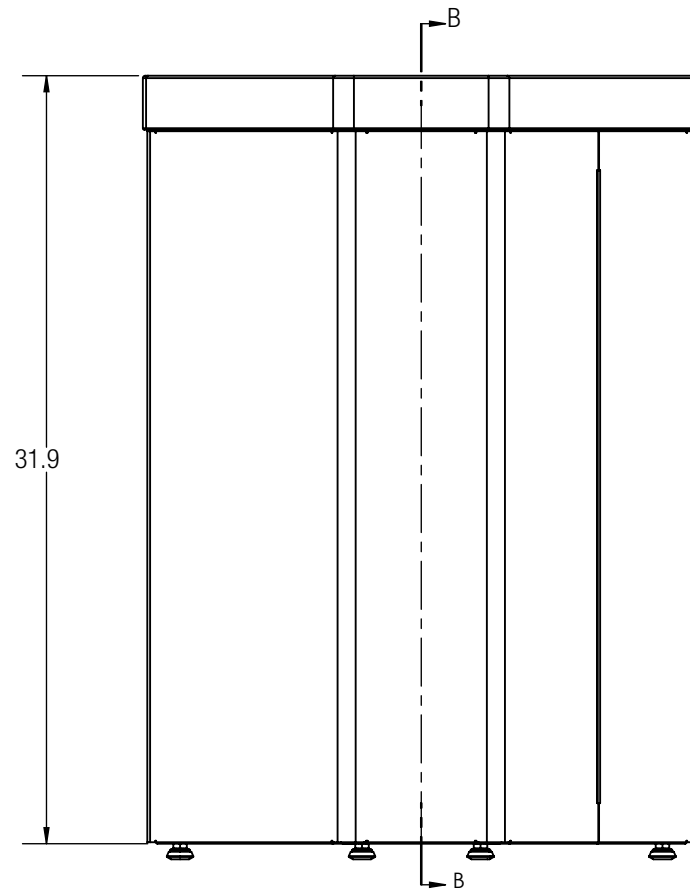

SECTION B-B

CUSTOMER APPROVAL:

X \_\_\_\_\_

DATE:

X \_\_\_\_\_

UNLESS OTHERWISE SPECIFIED,  
DIMENSIONS ARE IN INCHES

TOLERANCES (UNLESS OTHERWISE SPECIFIED):  
FRACTIONAL:  $\pm 1/32$   
ANGULAR/BEND:  $\pm 1^\circ$   
TWO PLACE DECIMAL:  $\pm .030$   
THREE PLACE DECIMAL:  $\pm .020$

MATERIAL: SEE DATA SHEET

FINISH: SEE DATA SHEET

WEIGHT: 50 LBS

SOURCE: MDW

SCALE: N.T.S.

**FORMS+SURFACES**® 30 Pine Street, Pittsburgh, PA 15223  
Tel (800) 451-0410 Fax (412) 781-7840

DATE  
03/19/2013

TRIAD RECEPTACLE (24 GALLON)  
SLTRD-24B  
SLTRD-24L  
SLTRD-24P

PROPRIETARY AND CONFIDENTIAL

THE INFORMATION CONTAINED IN THIS  
DRAWING IS THE SOLE PROPERTY OF  
FORMS + SURFACES. ANY REPRODUCTION  
IN PART OR AS A WHOLE WITHOUT  
WRITTEN PERMISSION IS PROHIBITED.

SIZE	DWG. NO.	REV	SHEET
B	SLTRD-24BLP-TD	000.0	1 OF 1