

# SURFACES









# CONTENTS



## SURFACES

	<b>6 VividGlass</b>
8	About VividGlass
10	ViviChrome Chromis
12	ViviChrome Chromis Applications
14	ViviChrome Scribe
16	ViviChrome Scribe Applications
18	ViviGraphix Graphica
20	ViviGraphix Graphica Applications
22	ViviGraphix Gradiance
24	ViviGraphix Gradiance Applications
26	ViviSpectra Elements
28	ViviSpectra Elements Applications
30	ViviSpectra Spectrum
32	ViviSpectra Spectrum Applications
34	ViviSpectra Zoom
36	ViviSpectra Zoom Applications
38	ViviSpectra VEKTR
40	ViviSpectra VEKTR Applications
42	ViviStone
44	ViviStone Applications
46	ViviStrata Monolithic
48	ViviStrata Monolithic Applications
50	ViviStrata Layers
52	ViviStrata Layers Applications
54	ViviTela Mesh
56	ViviTela Mesh Applications
58	Jot Mobile Glassboard
60	Finishes + LumiLevels

	<b>62 BermanGlass</b>
64	About BermanGlass
66	Classic Kiln Cast Glass
68	Classic Kiln Cast Glass Applications
70	Intervals Kiln Cast Glass
72	Intervals Kiln Cast Glass Applications
74	Profile Kiln Cast Glass
76	Profile Kiln Cast Glass Applications
78	Refract Kiln Cast Glass
80	Refract Kiln Cast Glass Applications
82	Levels Kiln Cast Glass
84	Levels Kiln Cast Glass Applications
86	Glass Hardware

	<b>88 Stainless Steel + Fused Metal</b>
90	About Stainless Steel + Fused Metal
92	Stainless Steel Finishes
94	Fused Metal Colors + Finishes
96	Eco-Etch Patterns
98	Impression Patterns
100	Fusion Patterns
102	Stainless Steel Applications
104	Fused Metal Applications

	<b>106 Linq Woven Metal</b>
108	About Linq Woven Metal
110	Linq Woven Metal
112	Linq Woven Metal Applications

	<b>114 Bonded Metal</b>
116	About Bonded Metal
118	Bonded Metal
122	Bonded Metal Applications
	<b>124 Bonded Quartz</b>
126	About Bonded Quartz
128	Bonded Quartz
130	Bonded Quartz Applications

## SYSTEMS

138	LEVELe Wall Cladding System
139	LightPlane Panels
140	Elevator Interiors + Doors
141	Columns + Column Covers

## DESIGN TOOLS

146	VEKTR Digital Canvas
148	Zoom Digital Darkroom
150	Virtual Quarry
152	Elevator Design Studio
154	Comprehensive Support
155	Additional Resources



# SURFACES

VividGlass

BermanGlass

Stainless Steel

Fused Metal

Linq Woven Metal

Bonded Metal

Bonded Quartz















# VIVIDGLASS

Reflecting more than 15 years of product innovation and the ongoing development of sophisticated in-house technologies, our specialty laminated glass gives you unrivaled creative freedom. The families within this group are each broadly defined by their visual characteristics: *ViviChrome* emphasizes solid color; *ViviGraphix* adds a diversity of graphic elements; *ViviSpectra* incorporates photos and other continuous tone color imagery; *ViviStrata* features precise etched designs; *ViviStone* brings the beauty of real stone to glass; and *ViviTela* captures the rich look of woven materials.

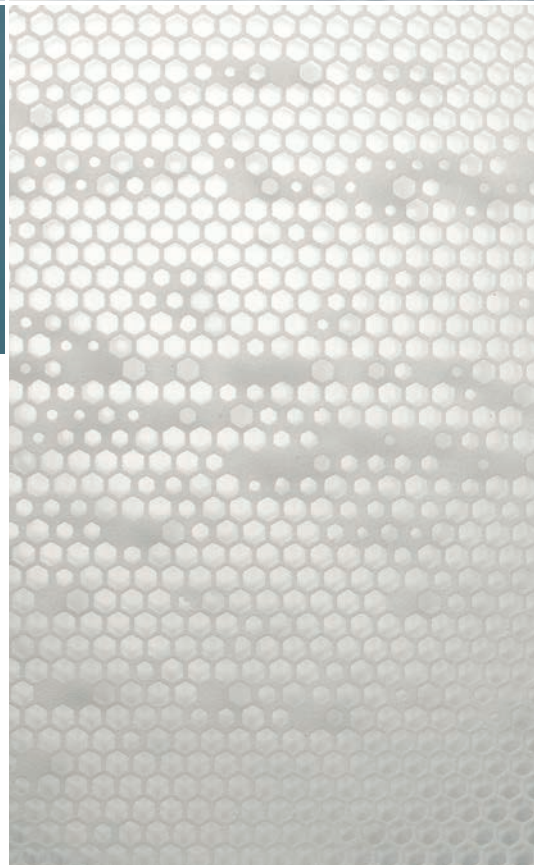
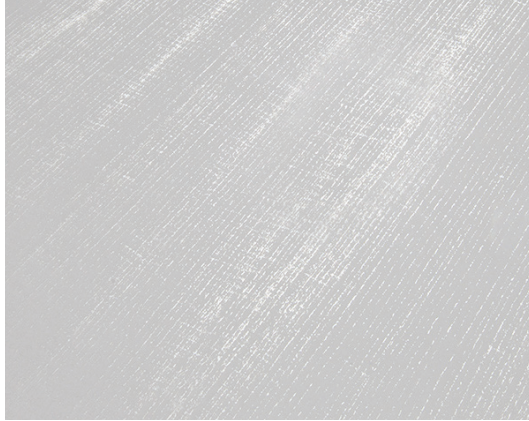

# ABOUT VIVIDGLASS

---

VividGlass is our line of architectural laminated glass. More than simply a finite palette of options, the families within this group are highly configurable and invite you to combine different visual elements to achieve the end results you desire.

Whether drawing from our standard offerings or incorporating your own custom imagery, VividGlass gives you the flexibility you need to transform indoor and outdoor settings of all kinds.

While details for each family are described on the following pages, it can help to understand several basic parameters that inform each VividGlass specification and can be used to optimize your glass design: Configurations, Interlayers, LumiLevels and Finishes.



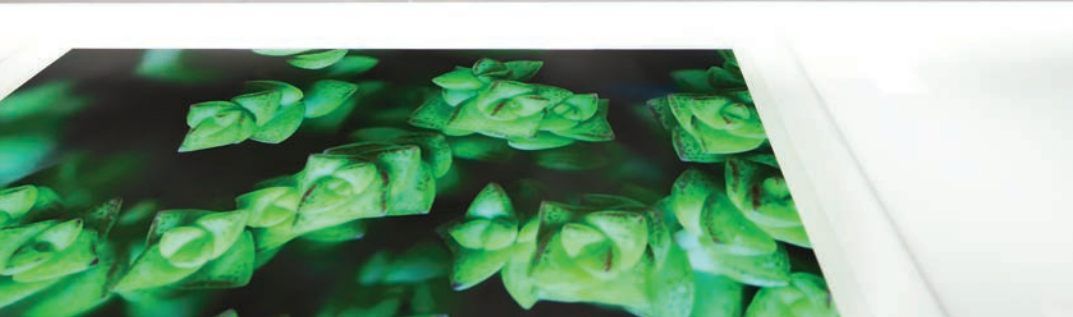

**Configuration** refers to the amount of light transmitted—or not—through VividGlass. To a large extent, the end use for your glass determines which configuration is used.

**View** is a single- or double-sided configuration with interlayer(s) laminated between two transparent lites of glass. View is typically used when the glass will be seen from both sides, as in partitions, room dividers, doors and other applications where semi-privacy is desired. It can also be used in backlit displays.

**Reflect** is a single-sided configuration with interlayer(s) laminated between a transparent lite of glass and a reflective glass backer. Reflect is intended for one-sided applications where the glass will be used against another surface—for example, on walls, columns or in elevator interiors.



**Interlayers** bring the visual excitement to VividGlass. Think of them as blank canvases that allow you to express your creative ideas. Choose from the many standard interlayer colors and patterns outlined on the following pages. Personalize a look with custom colors, graphics or project-themed artwork. Or create truly one-of-a-kind interlayer designs using our interactive design tools.

**LumiLevels** expand the functional reach of many VividGlass selections by providing variations in glass translucency levels. Six different LumiLevels ensure a full range of effects.

**Finishes** define the surface appearance of VividGlass and give you more ways to refine your finished design. Four standard options vary in levels of diffusion, reflectivity, glare and optical distortion, and provide unique solutions for meeting individual project needs.





A

B

C

D

E

F



# VIVICHROME CHROMIS

Bringing solid colors to life, ViviChrome Chromis invites you to choose from our standard interlayer colors or let us match your Benjamin Moore, Sherwin Williams, Pantone, or other custom color specification.

Chromis glass is available in View and Reflect configurations, all LumiLevel options, and Pearlex, Opalex and Standard finishes.

- A. Slate Blue + View + Standard
- B. Slate Blue + Reflect + Opalex
- C. Seaglass + Reflect + Opalex
- D. Seaglass + View + Standard
- E. Taupe + Reflect + Opalex
- F. Taupe + View + Standard
- G. Ice Grey + Reflect + Opalex
- H. White + Reflect + Opalex
- I. Ice Grey + View + Standard
- J. White + View + Standard
- K. Mirror Mist + Reflect + Opalex





# VIVICHROME CHROMIS APPLICATIONS



**Left:** ViviChrome Chromis glass, custom color interlayer, Pearlex finish; ViviGraphix Gradiance glass, custom color interlayer, Pearlex finish. Palo Alto Medical Foundation - San Carlos Center, San Carlos, California.

**Top Middle:** LEVELe-105 Elevator Interior and LEVELe Wall Cladding System: ViviChrome Chromis glass, custom color interlayer, Opalex finish; and Fused Graphite, Sandstone finish. Mission City Corporate Center, San Diego, California.

**Top Right:** LightPlane Panels in ViviChrome Chromis glass, Seaglass interlayer, Pearlex finish. Private location, Short Hills, New Jersey.

**Right:** LEVELe-107 Elevator Interior: ViviChrome Chromis glass, White interlayer, Pearlex finish; and Stainless Steel, Seastone finish, Dallas Impression pattern; LightPlane Panels in ViviChrome Chromis glass, custom color interlayer, Opalex finish. Shippan Landing, Stamford, Connecticut.

**Opposite Page:** LEVELe Wall Cladding System and LEVELe Column System: ViviChrome Chromis glass, White interlayer, Opalex finish. Bank of America Plaza, Nashville, Tennessee.









A



B

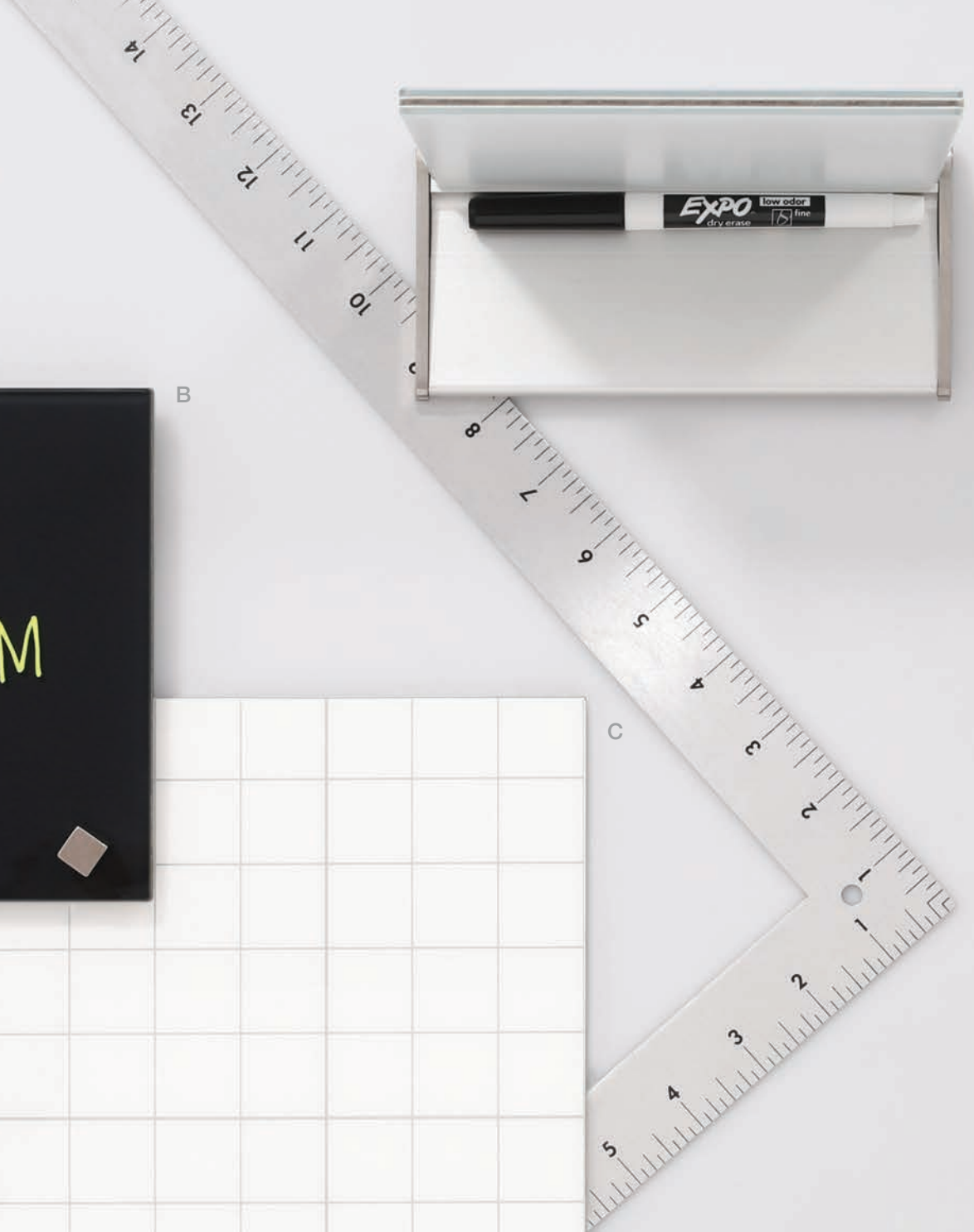
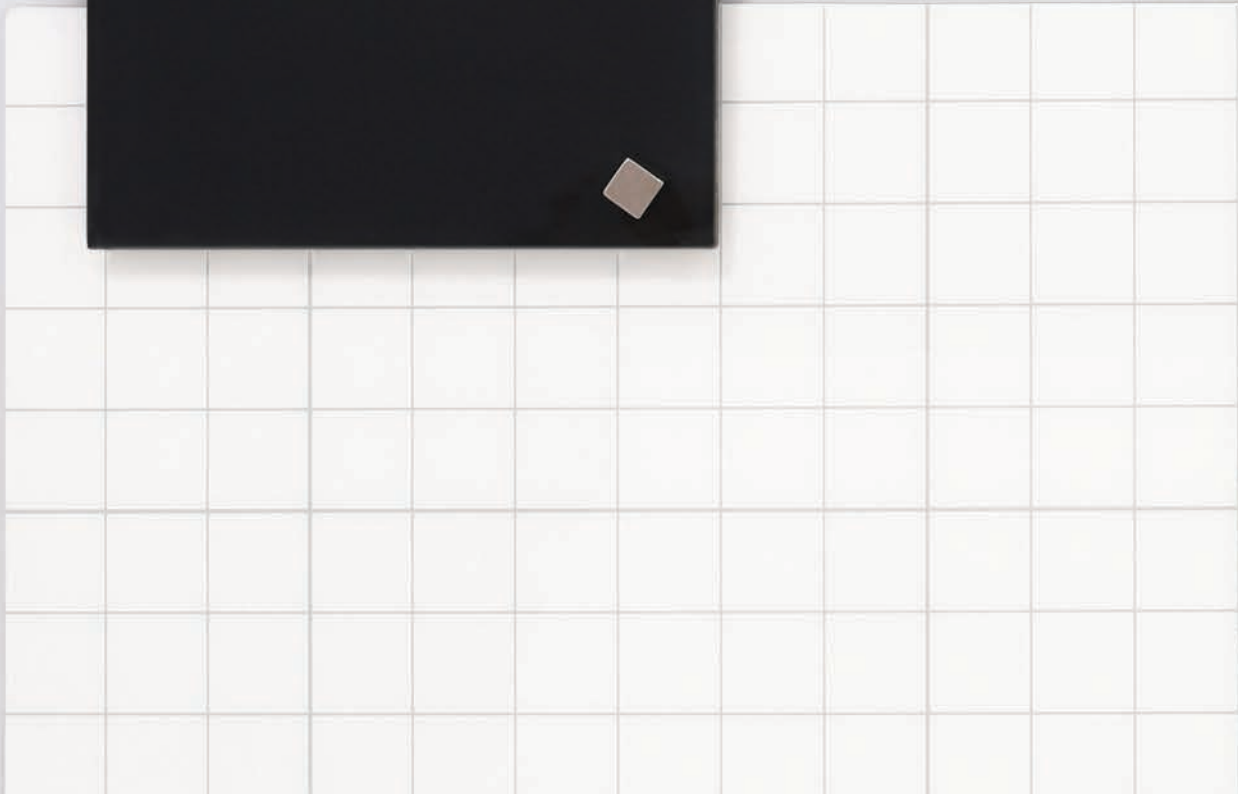

C



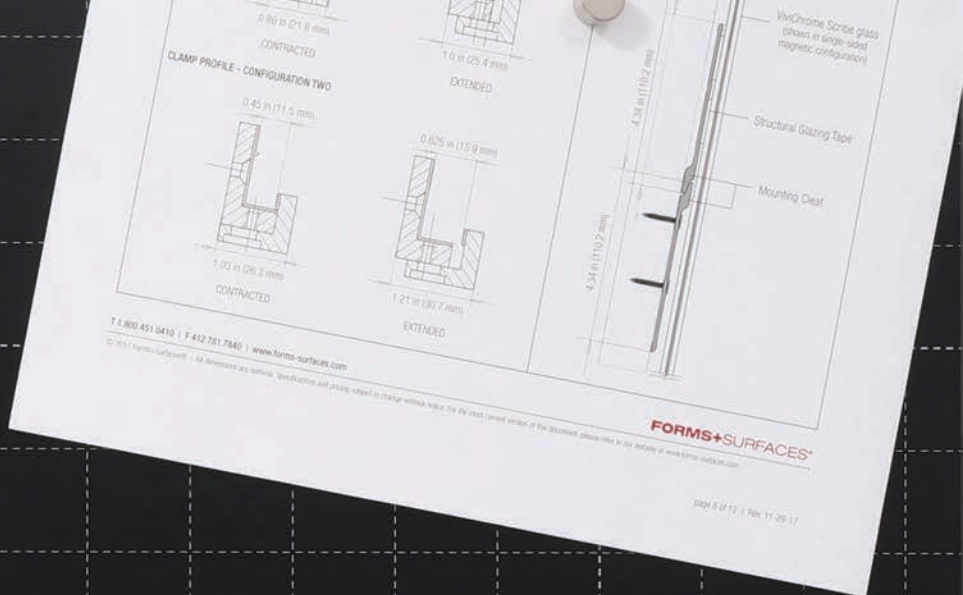

# VIVICHROME SCRIBE

ViviChrome Scribe offers spectacular performance as a writing board or creative wall. Designed for use with dry or wet erase markers and/or magnets, Scribe can be specified in standard or custom colors. Custom interlayer graphics are also an option.

Scribe glass is available in opaque single- and double-sided configurations and Pearlex and Standard finishes. Marker trays, magnets and mounting accessories are also available.

- A. Ultra White + Pearlex
- B. Blackboard + Pearlex
- C. Ultra White + Custom Graphic + Standard
- D. Blackboard + Custom Graphic + Standard
- E. Ultra White + Standard
- F. White + Custom Graphic + Standard



E

F

D



# VIVICHROME SCRIBE APPLICATIONS



**Left:** ViviChrome Scribe glass, custom clear and White interlayer. KI Showroom, Merchandise Mart, Chicago, Illinois.

**Top Middle:** ViviChrome Scribe glass, White interlayer, Standard finish. Northwestern University, Evanston, Illinois.

**Top Right:** LEVELe Wall Cladding System: ViviChrome Scribe glass, Blackboard interlayer, Standard finish; and Stainless Steel, Sandstone finish, Dallas Impression pattern. Fresenius Medical Care, Nashville, Tennessee.

**Right:** Partition walls in ViviChrome Scribe glass, White interlayer, Standard finish. Ammirati, New York, New York.

**Opposite Page:** LEVELe Wall Cladding System: ViviChrome Scribe glass, Ultra White interlayer, Standard finish; and custom acrylic logo graphics. NAV Consulting, Oakbrook Terrace, Illinois.





NAV  
CONSULTING





A

E

B

F

G

H

C

D

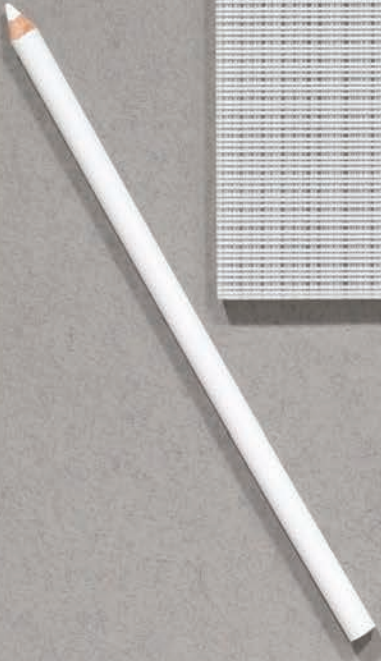
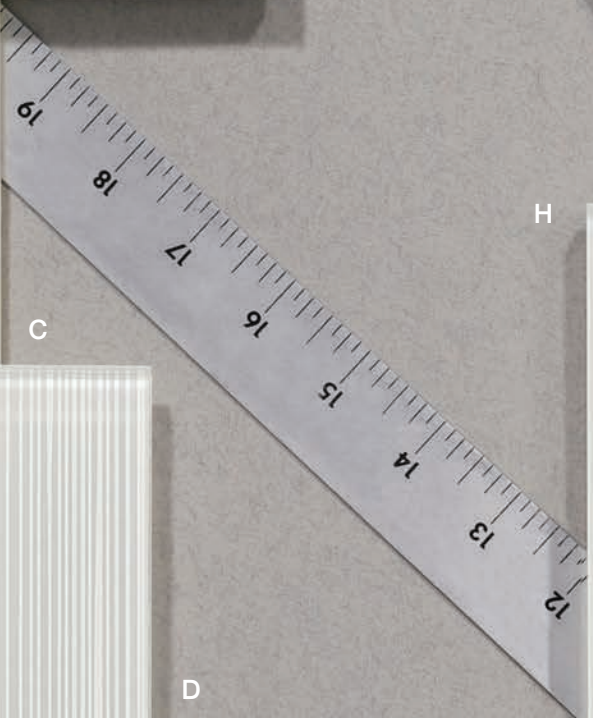





# VIVIGRAPHIX GRAPHICA

ViviGraphix Graphica features color graphic patterns in single or multiple interlayers. Options include our standard patterns and ViviChrome Chromis colors, or virtually any custom graphic or color.

Graphica glass can be specified in View and Reflect configurations, all LumiLevel options, and Pearlex and Standard finishes.

- A. Seagrass + White + Reflect + Pearlex
- B. Drift + Custom Color + Reflect + Standard
- C. Frost + White + Reflect + Standard
- D. Silkworm + White + View + Standard
- E. Centene + White + View + Standard
- F. Glacier + Custom Color + Reflect + Standard
- G. Dot Medium + White + View + Standard
- H. Current + White + Reflect + Standard
- I. Glacier + White + Reflect + Standard
- J. Cairo + White + Custom View + Standard
- K. Drift + White + View + Standard
- L. Cairo + Custom Color + Reflect + Standard
- M. Cairo + White + View + Standard



# VIVIGRAPHIX GRAPHICA APPLICATIONS



**Left:** LEVELe-102 Elevator Interior with customized panel layout: ViviGraphix Graphica glass, Cairo interlayer in White, Standard finish; and American Cherry with Dark Mahogany Stain wood veneer. Sallie Mae, Newark, Delaware.

**Top Middle:** ViviGraphix Graphica glass, custom graphic interlayer in White, Standard finish. Duluth International Airport, Duluth, Minnesota.

**Top Right:** LEVELe-105 Elevator Interior: ViviGraphix Graphica glass, customized Silkworm interlayer in White, Standard finish; and Bonded Bronze, Dark Patina, Rain pattern. Grand Hyatt Washington, Washington, D.C.

**Right:** Partition wall in ViviGraphix Graphica glass, Current interlayer in White, Standard finish. Presidential City Apartments, Philadelphia, Pennsylvania.

**Opposite Page:** LightPlane Panels in ViviGraphix Graphica glass, custom graphic interlayer in Metallic Silver, Standard finish. Esperson Buildings, Houston, Texas.







PERSON





A



B

D

C





# VIVIGRAPHIX GRADIANCE

ViviGraphix Gradiance patterns can fade from opaque to clear in numerous ways. Ideal for applications where semi-privacy is desired, the rate and degree of fade can be tailored to project-specific needs.

Gradiance glass is available with one or more color graphic interlayers in a double-sided View configuration. Options include our standard patterns and ViviChrome Chromis colors, or virtually any custom graphic or color. Finishes include Pearlex and Standard. All LumiLevel options are available.

- A. Dot Mini Fade + White + View + Standard
- B. Scatter + Custom Color + View + Standard
- C. Montane + White + View + Standard
- D. Dot Mini Fade + Custom Color + View + Pearlex
- E. Switchgrass + White + View + Standard
- F. Vapor + White + View + Standard
- G. Scatter + White + View + Standard



# VIVIGRAPHIX GRADIANCE APPLICATIONS



**Left:** Doors and transom in ViviGraphix Gradiance glass, Scatter interlayer in White, Standard finish. Elinor Bunin Munroe Film Center, New York, New York.

**Top Middle:** Partition wall in ViviGraphix Gradiance glass, custom graphic interlayer in White, Standard finish. Schaumburg Toyota, Schaumburg, Illinois.

**Top Right:** Partition wall in ViviGraphix Gradiance glass, Scatter interlayer in White, Standard finish. Florida International University - Ryder School of Business, Media Labs, Miami, Florida.

**Right:** Partition wall in ViviGraphix Gradiance glass, custom Switchgrass interlayer in White, Standard finish. San Diego Marriott La Jolla, La Jolla, California.

**Opposite Page:** Partition wall in ViviGraphix Gradiance glass, custom graphic interlayer in White, Standard finish. McShane Construction Company, Rosemont, Illinois.





MC SHANE  
CONSTRUCTION  
C O M P A N Y

CONOR  
COMMERCIAL  
REAL ESTATE





A



D



B

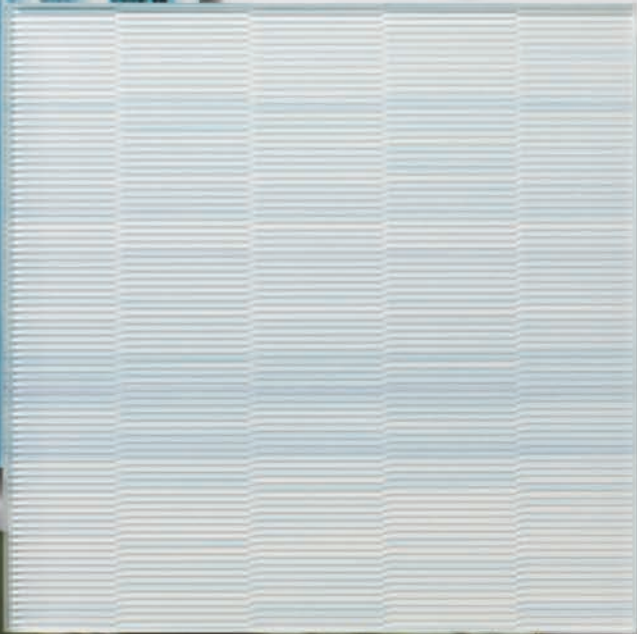

G



E



F



C





# VIVISPECTRA ELEMENTS

Capturing the rhythms of nature in glass, ViviSpectra Elements subtly brings the outdoors in with a series of continuous tone color images sourced from wood, stone, botanicals and other natural themes.

Elements glass is available in View and Reflect configurations and Pearlex and Standard finishes.

- A. Yucca Blue + View + Standard
- B. Marea + Reflect + Standard
- C. Yucca + View + Pearlex
- D. Tali + View + Standard
- E. Tandarra + Reflect + Standard
- F. Umbra + View + Standard
- G. Timber + Reflect + Standard
- H. Black Fig + View + Standard
- I. Strata + View + Pearlex
- J. Black Marble + Reflect + Standard
- K. Raya + Reflect + Standard
- L. White Marble + Reflect + Standard



# VIVISPECTRA ELEMENTS APPLICATIONS



**Left:** Wall panels in ViviSpectra Elements glass, Tandarra interlayer, Standard finish.

**Top Middle:** LEVELe-105 Elevator Interior with customized panel layout: LightPlane Panels in ViviSpectra Elements glass, custom Black Fig interlayer, Standard finish; and Stainless Steel, custom finish. Private location, Chicago, Illinois.

**Top Right:** LEVELe-107 Elevator Interior with customized panel layout: LightPlane Panels in ViviSpectra Elements glass, custom Yucca Blue interlayer, Standard finish; ViviSpectra Elements glass, Black Fig interlayer, Standard finish; and ViviChrome Chromis glass, White interlayer, Standard finish. Private location, Dallas, Texas.

**Right:** LEVELe-107 Elevator Interior: LightPlane Panels in ViviSpectra Elements glass, Yucca pattern, Pearlex finish; and Bonded Bronze, Dark Patina, Trevia pattern. 1520 & 1528 Woodward Avenue, Detroit, Michigan.

**Opposite Page:** LightPlane Panels in ViviSpectra Elements glass, Acero interlayer, Pearlex finish. Axis Apartments & Lofts, Chicago, Illinois.









A



B

C

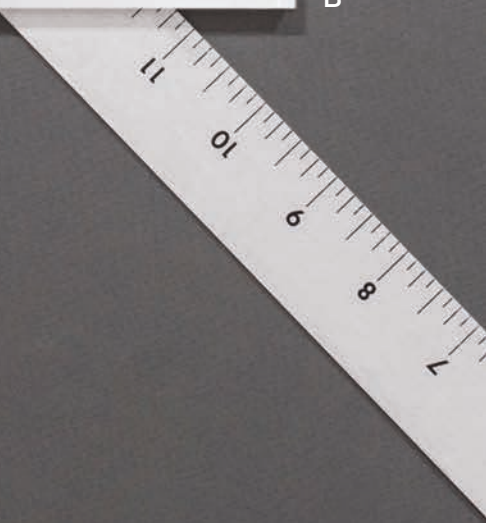





## VIVISPECTRA SPECTRUM

ViviSpectra Spectrum interlayers incorporate customer-supplied photos, digital files, and other continuous tone color imagery.

Spectrum is a great choice if you already have the imagery you want to use, and the image file is large enough to fit your intended application (supplied imagery must be a minimum of 300 dpi at scale). Artwork that ties to a project's design theme, features logos or branding graphics, or displays wayfinding elements are some of the ways customers have incorporated their own artwork into ViviSpectra Spectrum glass.

Spectrum glass can be specified in View and Reflect configurations, all LumiLevel options, and Pearlex and Standard finishes.

- A. Custom Image + Reflect + Standard
- B. Custom Image + Reflect + Pearlex
- C. Custom Image + View + Standard
- D. Custom Image + Reflect + Standard
- E. Custom Image + View + Standard



# VIVISPECTRA SPECTRUM APPLICATIONS



**Left:** LightPlane Panels in ViviSpectra Spectrum glass, custom image interlayer, Standard finish. Blue Cross and Blue Shield of Kansas City, Kansas City, Missouri.

**Top Middle:** LEVELe Wall Cladding System: ViviSpectra Spectrum glass, custom image interlayer, Standard finish. Nationwide Children's Hospital - Research Building III, Columbus, Ohio.

**Top Right:** Partition wall in ViviSpectra Spectrum glass, custom image interlayer, Pearlex finish. University Health System - Robert B. Green Campus, San Antonio, Texas.

**Right:** LightPlane Panels in ViviSpectra Spectrum glass, custom image interlayer, Standard finish. Chicago Transit Authority, Washington/Wabash Station, Chicago, Illinois.

**Opposite Page:** ViviSpectra Spectrum glass, custom image interlayer, Standard finish. University Health System - University Hospital, San Antonio, Texas.











A



C

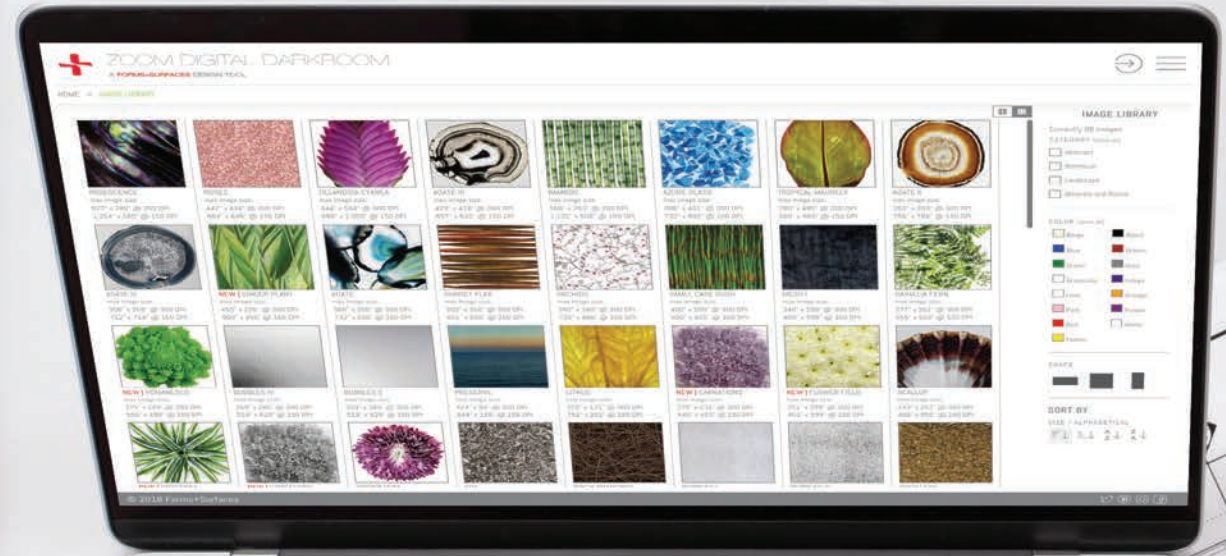

B





# VIVISPECTRA ZOOM

ViviSpectra Zoom interlayers incorporate Zoom images from our growing library of large-scale, super-high-resolution photos.

Ranging from sweeping panoramic vistas to intriguing close-ups of nature and the world around us, Zoom images are accessible through the Zoom Digital Darkroom—our interactive design tool that gives you endless ways to create highly original photographic designs.

Zoom glass is available in View and Reflect configurations, all LumiLevel options, and Pearlex and Standard finishes.

Learn more about the Zoom Digital Darkroom on pages 148-149.

- A. Iridescence + Reflect + Standard
- B. Carnations + Reflect + Standard
- C. Sacramento Mountains + Reflect + Standard
- D. Freshwater Stones + Reflect + Standard
- E. Feather Grass + View + Pearlex
- F. Agate + View + Standard





# VIVISPECTRA ZOOM APPLICATIONS



**Left:** Partition wall in ViviSpectra Zoom glass, Carnations Greyscale interlayer.

**Top Middle:** LEVELe-106 Elevator Interior: LightPlane Panels in ViviSpectra Zoom glass, Canopy interlayer.

**Top Right:** Backlit reception desk in ViviSpectra Zoom glass, Gold Leaf interlayer.

**Right:** LightPlane Panels in ViviSpectra Zoom glass, Azure interlayer.

**Opposite page:** Feature wall in ViviSpectra Zoom glass, Flower Field interlayer.











A

B

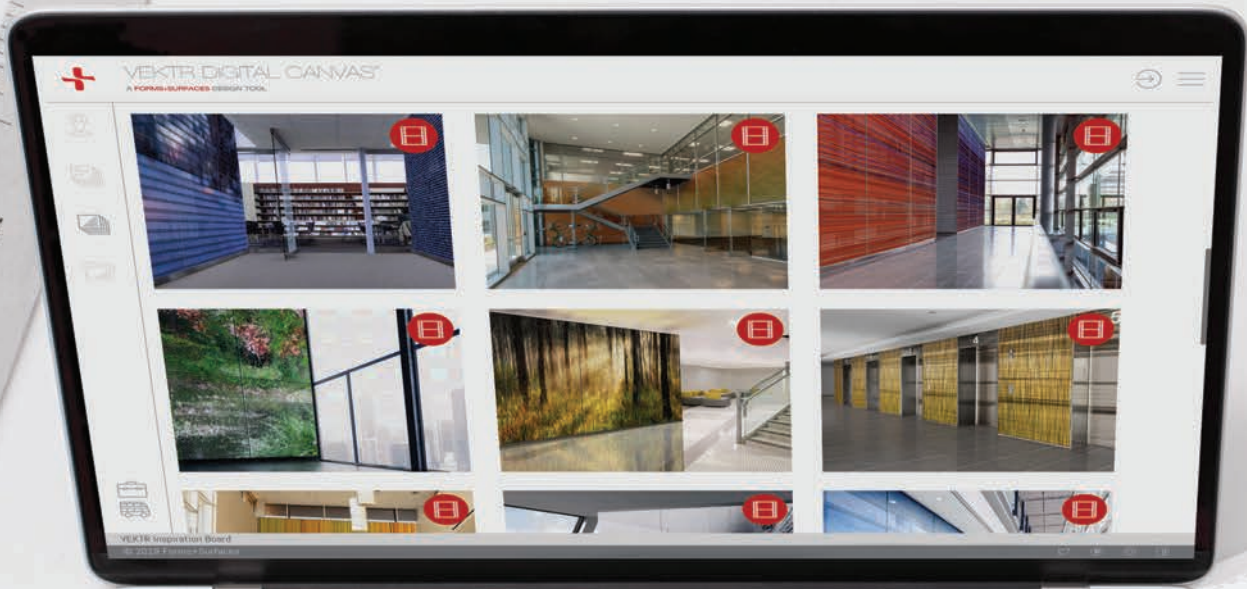





# VIVISPECTRA VEKTR

ViviSpectra VEKTR interlayers feature customized interpretations of your own digital imagery, which you create using the VEKTR Digital Canvas (VDC), another of our interactive design tools.

Putting artistic control at your fingertips, the VDC lets you transform digital images of any size from any source into infinitely scalable vector artwork that's output as continuous tone interlayers in VEKTR glass.

VEKTR glass can be specified in View and Reflect configurations, all LumiLevel options, and Pearlex and Standard finishes.

Learn more about the VEKTR Digital Canvas on pages 146-147.

- A. Custom Image + Crimp Filter + Reflect + Standard
- B. Custom Image + Zag Filter + Reflect + Standard
- C. Custom Image + Glacier Filter + Reflect + Standard
- D. Custom Image + Scatter Filter + Reflect + Pearlex
- E. Custom Image + Stripes Filter + View + Standard



# VIVISPECTRA VEKTR APPLICATIONS



**Left:** Wall panels in ViviSpectra VEKTR glass, Pearlex finish.

**Top Middle:** LEVELe Wall Cladding System: ViviSpectra VEKTR glass, Standard finish.

**Top Right:** Partition wall in ViviSpectra VEKTR glass, Standard finish.

**Right:** LEVELe Wall Cladding System: ViviSpectra VEKTR glass, Pearlex finish.

**Opposite Page:** LEVELe Wall Cladding System: ViviSpectra VEKTR glass, Standard finish; custom base.











A



B



**VIRTUAL QUARRY**  
A FORMS+SURFACES DESIGN TOOL

Welcome Back | Log out | My Account | New Project



**Virtual Quarry | Step 1 of 4: Select Your Stone and Master Slab**

VIRTUAL QUARRY  
STEP BY STEP NAVIGATION

1. SELECTION 2. DIMENSIONS 3. CONFIGURATION 4. REVIEW

SHOW YOUR SLAB PORTFOLIO

**ViviStone Families**

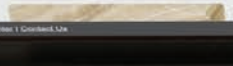
	<p><b>WHITE ONYX</b> White Onyx is a modern take on a classic neutral aesthetic. Subtle shifts of white and grey, accented by charcoal veining, give White Onyx character and dimension without overpowering.</p> <p><a href="#">View Slab</a></p>
	<p><b>OPAL ONYX</b> Opal Onyx features milky, amorphous shapes in a pale spectrum of white, buttercream, rose and blue-grey. With its delicate veining and detail, Opal Onyx brings warmth and harmony to any space.</p> <p><a href="#">View Slab</a></p>
	<p><b>PEARL ONYX</b> Pearl Onyx is a neutral pattern comprised of a cool palette of white, blue-grey and taupe. This elegant stone features fine, coral-like details as well as large gradient areas reminiscent of a solitary landscape.</p> <p><a href="#">View Slab</a></p>
	<p><b>CREAM ONYX</b> Cream Onyx gently glows with the warmest tones of amber and white, with an occasional pop</p> <p><a href="#">View Slab</a></p>

Virtual Quarry. Research. Select. | Contact Us

C

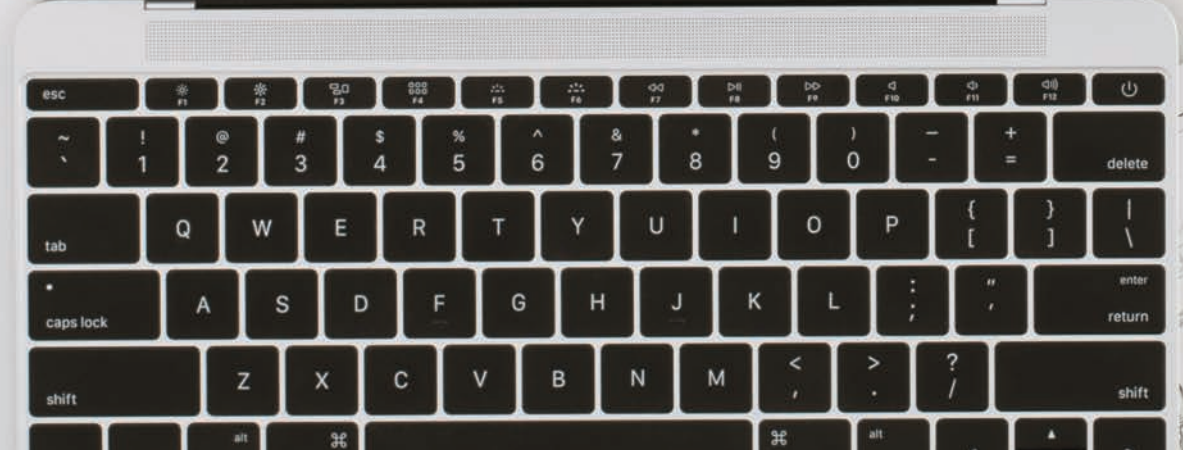





# VIVISTONE

Uniting the beauty of real stone with the convenience of architectural glass, Vivistone's graphic interlayers are ultra-sharp, full-scale representations of stones from around the world.

Each Vivistone family consists of a library of slabs that offer beautiful variations in color and graining. Slabs can be used in their entirety, or smaller sections can be defined, mirrored, rotated, and repeated to create highly original layouts—configuration is easy with our Virtual Quarry design tool.

Vivistone is available in View and Reflect configurations, and Pearlex and Standard finishes.

Learn more about the Virtual Quarry on pages 150-151.

- A. Opal Onyx + View + Standard
- B. Pearl Onyx + Reflect + Pearlex
- C. Honey Onyx + View + Pearlex
- D. White Onyx + Reflect + Pearlex
- E. Abalone Onyx + View + Standard
- F. Cream Onyx + Reflect + Pearlex



# VIVISTONE APPLICATIONS



**Left:** LEVELc-2000N Elevator Interior: ViviStone Honey Onyx, Pearlex finish; Mirror glass; Stainless Steel, Linen finish; and stiles and rails in Stainless Steel, Seastone finish. Woolworth Building, Eugene, Oregon

**Top Middle:** LightPlane Panels in ViviStone Opal Onyx glass, Pearlex finish. UCLA Health - Santa Clarita Imaging and Interventional Center - Radiology, Los Angeles, California.

**Top Right:** LEVELe Wall Cladding System: LightPlane Panels in ViviStone White Onyx glass, Pearlex finish. Oakbrook Office North, Oak Brook, Illinois.

**Right:** LEVELe-106 Elevator Interior: LightPlane Panels in ViviStone Pearl Onyx glass, Pearlex finish; ViviChrome Chromis glass, Slate Blue interlayer, Pearlex finish; and Stainless Steel, Seastone finish. 1100 Louisiana Street, Houston, Texas.

**Opposite Page:** Reception desk in ViviStone Cream Onyx glass, Standard finish. Omni Nashville Hotel, Nashville, Tennessee.











A

B

C

D





# VIVISTRATA MONOLITHIC

ViviStrata Monolithic glass is comprised of a single tempered glass lite with etching on one or both sides. Our proprietary etching process is extremely precise and allows us to produce crisp details, fine lines, and intricate small-scale patterns and etched designs.

An invisible protective sealer on the glass repels dirt, makes the glass easy to clean, and ensures the long-lasting beauty of each etched surface.

All patterns at left are shown in the double-sided etching configuration.

- A. Plot
- B. Stripes
- C. Hive
- D. Ripple
- E. Palisade
- F. Canopy
- G. Glint
- H. Surge





# VIVISTRATA MONOLITHIC APPLICATIONS

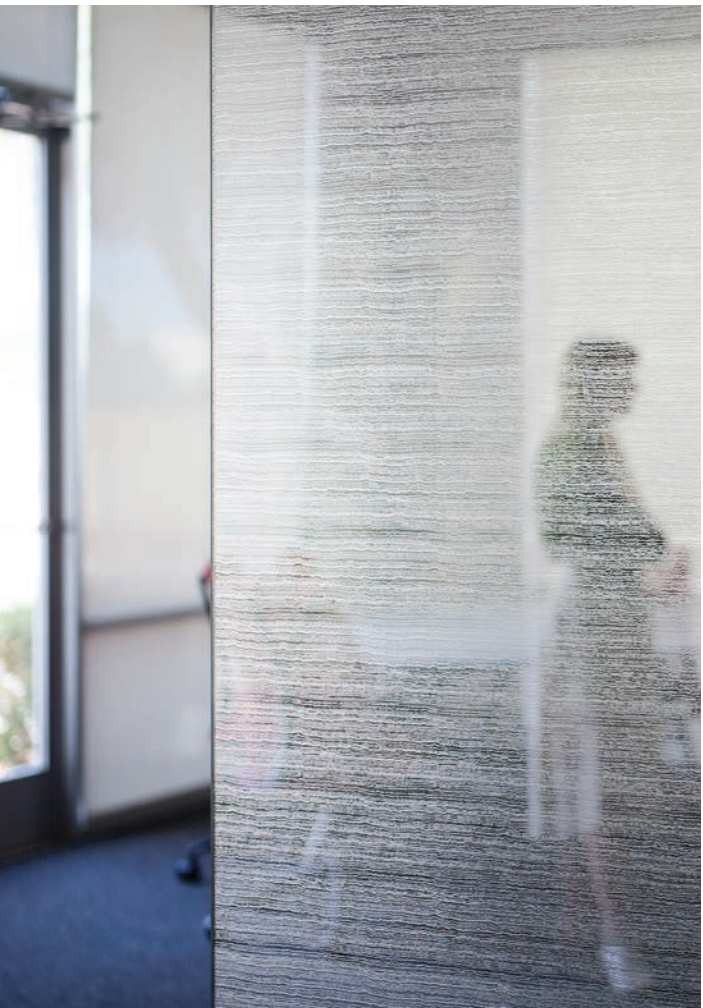

**Left:** Vivistrata Monolithic glass in Ripple pattern.

**Top Middle:** Vivistrata Monolithic glass in Ripple pattern.

**Top Right:** Vivistrata Monolithic glass in Ripple pattern.

**Right:** Vivistrata Monolithic glass in Hive pattern.

**Opposite Page:** Vivistrata Monolithic glass in Hive pattern.

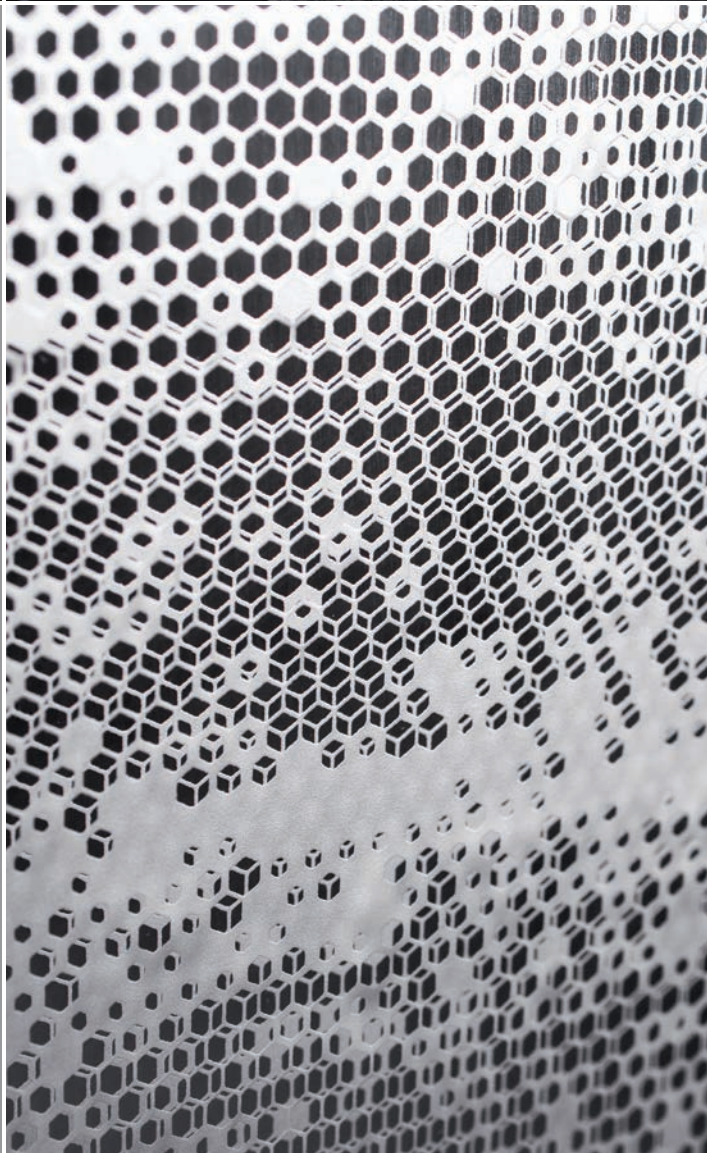







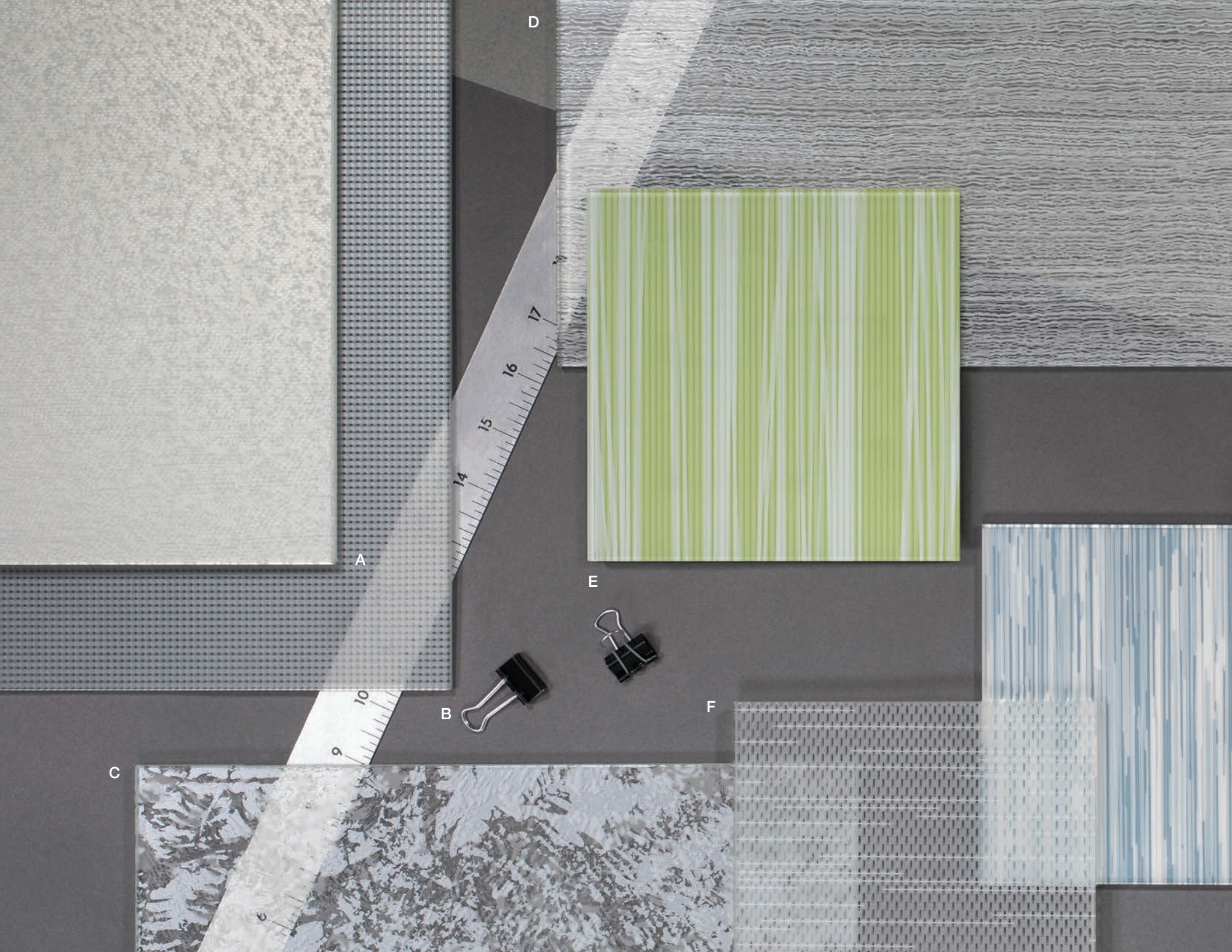

D

A

E

B

F

C





# VIVISTRATA LAYERS

ViviStrata Layers glass features one or two color graphic interlayers laminated between two lites of glass, with precise etched designs on one or both glass lites. Each multi-layered pattern is a dynamic play between interlayer graphics, etched elements, and light.

An invisible protective sealer on the glass repels dirt, makes the glass easy to clean, and ensures the long-lasting beauty of each etched surface.

Layers glass is available in View and Reflect configurations, all LumiLevel options, and Standard finish.

- A. Glint + White + Reflect
- B. Plot + White + View
- C. Canopy + White + View
- D. Ripple + White + View
- E. Palisade + Custom Color + Reflect
- F. Glide + Metallic Silver + View
- G. Surge + Custom Color + Reflect
- H. Palisade + White + View
- I. Palisade + Custom Color + Reflect
- J. Surge + White + Reflect
- K. Hive + White + Reflect





# VIVISTRATA LAYERS APPLICATIONS



**Left:** ViviStrata Layers glass, Glide pattern in Metallic Silver.

**Top Middle:** ViviStrata Layers glass, Surge pattern in Slate Blue.

**Top Right:** ViviStrata Layers glass, Glint pattern in White.

**Right:** ViviStrata Layers glass, Palisade pattern in White.

**Opposite Page:** ViviStrata Layers glass, Glide pattern in Metallic Silver.











A

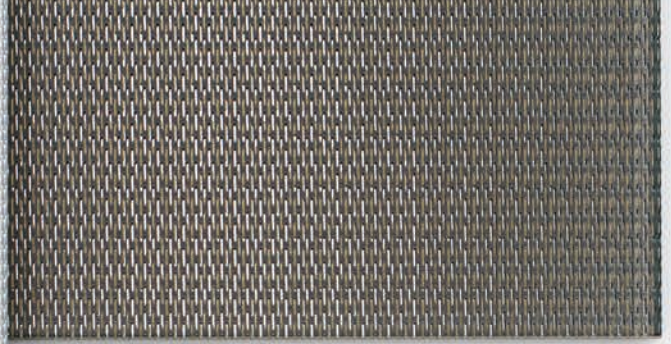

D



B

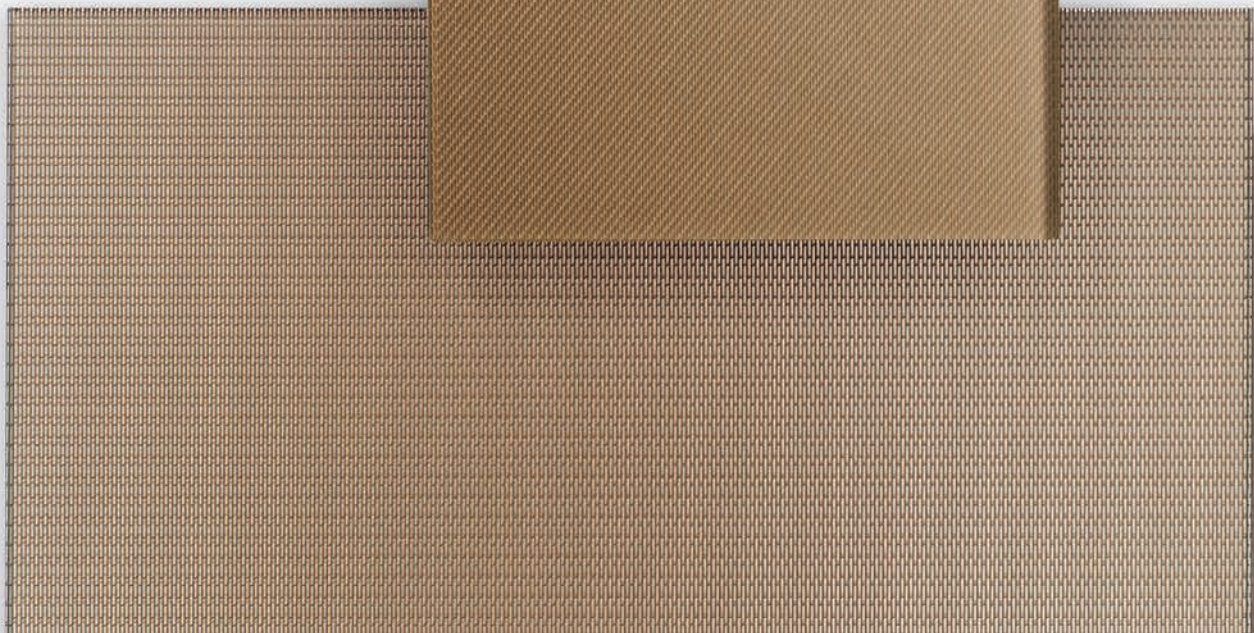

C







## VIVITELA MESH

ViviTela Mesh brings the rich look of woven metal to glass. Our highly controlled production processes ensure precise, consistent patterns – across individual glass lites and from one lite to the next – without the runs, folds or other imperfections often seen with laminated metals or fabrics.

ViviTela Mesh patterns are available in colors that match other F+S metals so it's easy to bring a cohesive look to a project. Finish options include Pearlex+ and Standard.

- A. Pointed Twill + Stainless Steel + Reflect + Pearlex+
- B. Twill + Bronze + Reflect + Standard
- C. Oxford + Nickel Bronze + Reflect + Pearlex+
- D. Overlay + Nickel Silver + Reflect + Standard
- E. Framework + White Gold + Reflect + Standard
- F. Overlay + Nickel Silver + Reflect + Standard
- G. Pointed Twill + Stainless Steel + Reflect + Pearlex+





# VIVITELA MESH APPLICATIONS



**Left:** ViviTela Mesh glass, Oxford interlayer in Nickel Bronze, Pearlex+ finish.

**Top Middle:** ViviTela Mesh glass, Twill interlayer in Bronze, Standard finish.

**Top Right:** ViviTela Mesh glass, Pointed Twill interlayer in Stainless Steel, Pearlex+ finish.

**Right:** ViviTela Mesh glass, Framework interlayer in White Gold, Standard finish.

**Opposite Page:** ViviTela Mesh glass, Overlay interlayer in Nickel Silver, Standard finish.















# JOT MOBILE GLASSBOARD

Jot is a double-sided, magnetic glassboard with sleek aesthetics and mobile, go-anywhere appeal. Angled legs make it easy to arrange Jot into layouts of different shapes and sizes. They also take Jot from in-use to in-storage quickly and efficiently: glassboards nest for a minimal, space-saving footprint.

Jot incorporates ultra-thin, ultra-durable Diamalite glass with a magnetic interlayer. The glass is erasable, non-ghosting and easily cleaned. Jot's aluminum frame has a durable powdercoat finish. Full-rotation lockable casters provide seamless mobility.

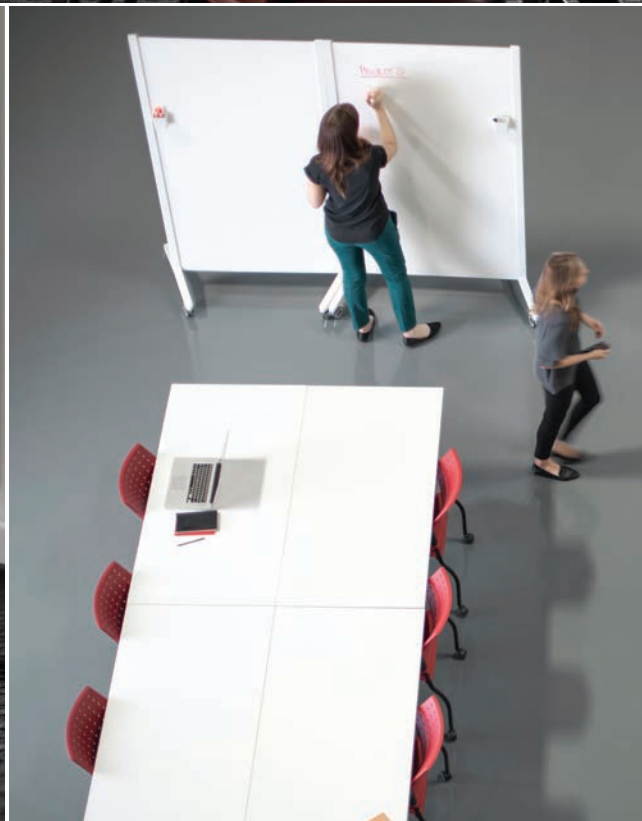



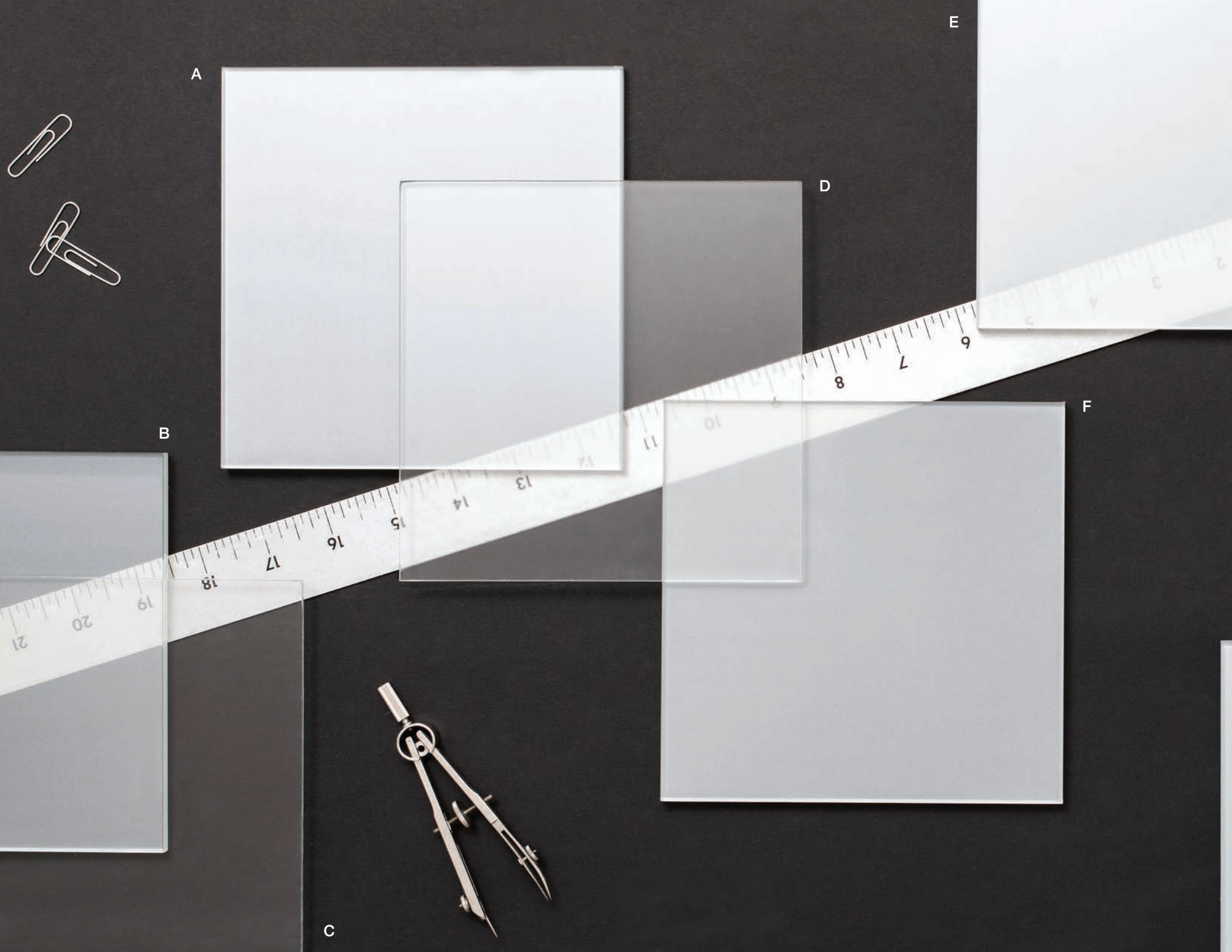

A

E

D

B

F

C





## FINISHES + LUMILEVELS

Finish and LumiLevel options vary per VividGlass family as noted on the preceding pages.

Finishes define the surface appearance of the glass:

Opalex has a very finely etched surface that creates a moderate amount of diffusion, is nonreflective and fingerprint-resistant.

Pearlex and Pearlex+ have finely etched surfaces that create a minimal amount of diffusion, are non-reflective, and fingerprint-resistant.

Standard finish is reflective and non-distortive.

LumiLevel is a measurement of the translucency of View glass. It can also be used to diffuse light from the reflective glass backer in Reflect glass.

There are six LumiLevel options.

- A. LumiLevel #2
- B. LumiLevel #1
- C. Standard Finish
- D. Pearlex Finish
- E. LumiLevel #4
- F. LumiLevel #3
- G. LumiLevel #5
- H. Opalex Finish
- I. LumiLevel #6
- J. Pearlex+ Finish











# BERMANGLASS

BermanGlass expands the creative reach of the F+S glass program by bringing artisanal sculptural textures into the mix. Building upon a long history of kiln cast glass design and manufacturing, the line is shaped by five different families, each with its own visual characteristics: Levels glass pairs artisanal cast glass textures with laminated color and graphic interlayers; Intervals introduces precise, small-scale textures; Profile is defined by linear motifs; Refract features deeply sculpted surfaces; and Classic designs have a timeless, handcrafted feel.

Created when Joel Berman Glass Studios joined the F+S family, BermanGlass unites artistic glass design with the technical expertise and uncompromising quality for which F+S is known.



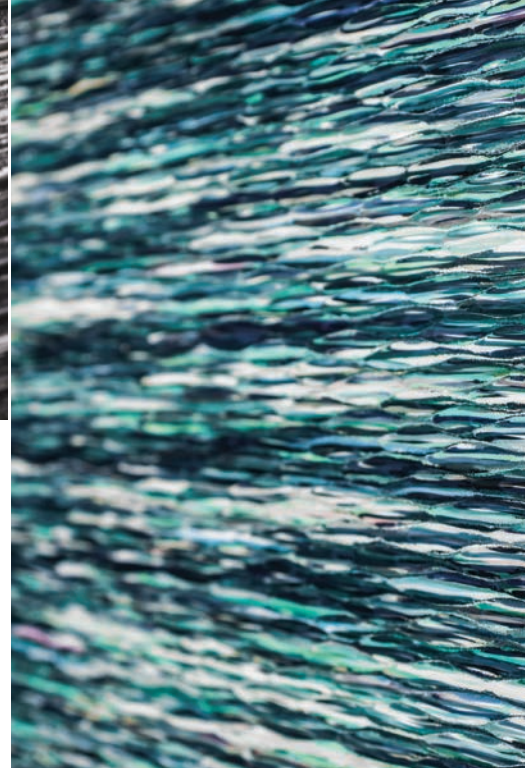
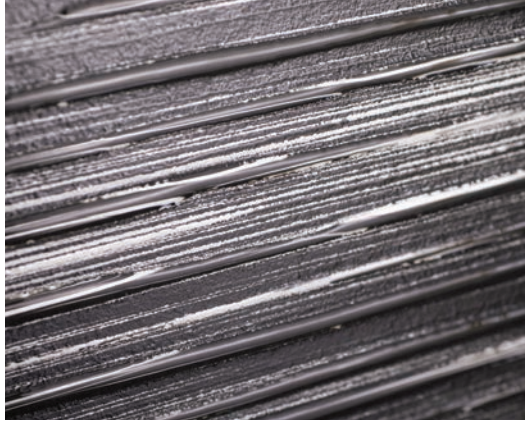

## ABOUT BERMANGLASS

---

BermanGlass is the result of more than three decades of glass innovation and experimentation. Over the years the line has become known for its pioneering kiln cast glass designs and uncompromising attention to detail.

From the beginning, BermanGlass has pushed the boundaries of what can be achieved in architectural glass. The line's artistic forms and textures have established expressive new possibilities for kiln cast glass and evolved a visual language that continues to inform glass design all over the world.

BermanGlass can be found on projects large and small, in corporate, commercial, hospitality, and healthcare settings, indoors and out.

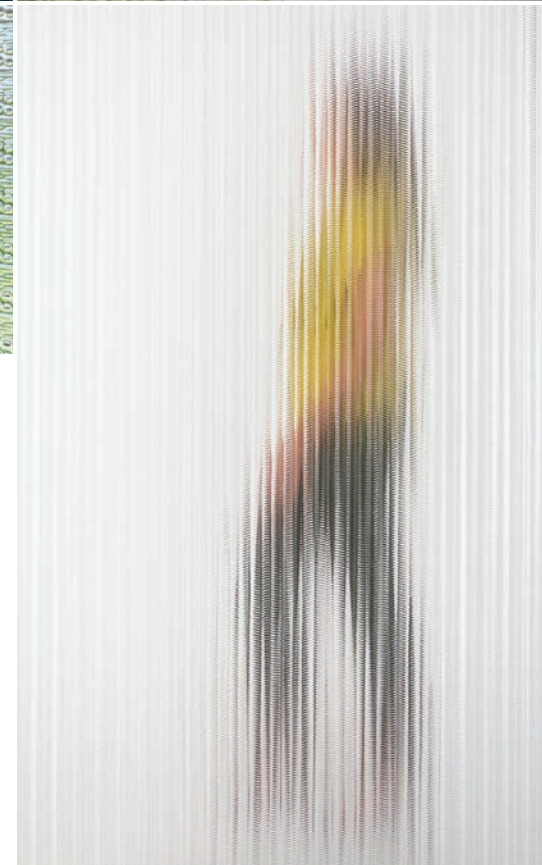
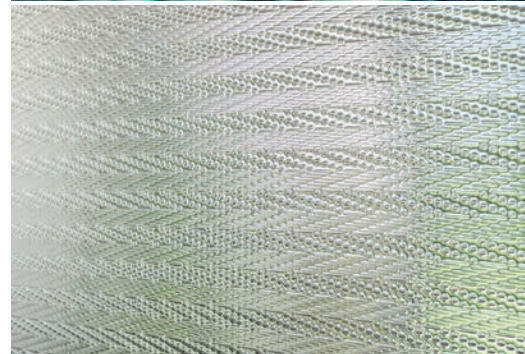





Traditionally, master mold makers carved BermanGlass molds by hand. Today, we're still hands-on. But as new technologies evolve, so too does our ability to move into new visual territories and reach new levels of efficiency without sacrificing the artisanal character of our most time-honored original designs.

Experimentation leads to discovery in the F+S Design Studio. As we explore synergistic possibilities that unite our diverse glass capabilities, our ongoing research and development efforts, growing in-house production facilities, and skilled teams of artisans and technicians inform and inspire our ideas and propel the BermanGlass line forward.

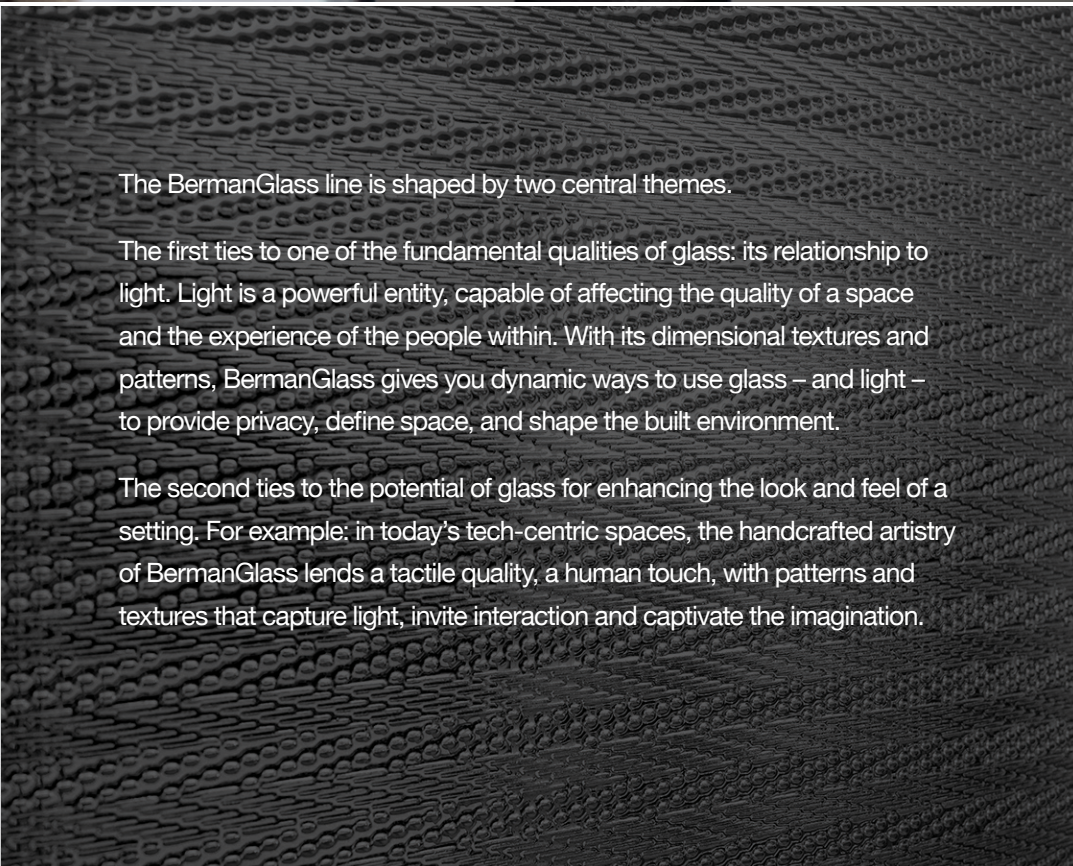

The BermanGlass line is shaped by two central themes.

The first ties to one of the fundamental qualities of glass: its relationship to light. Light is a powerful entity, capable of affecting the quality of a space and the experience of the people within. With its dimensional textures and patterns, BermanGlass gives you dynamic ways to use glass – and light – to provide privacy, define space, and shape the built environment.

The second ties to the potential of glass for enhancing the look and feel of a setting. For example: in today's tech-centric spaces, the handcrafted artistry of BermanGlass lends a tactile quality, a human touch, with patterns and textures that capture light, invite interaction and captivate the imagination.





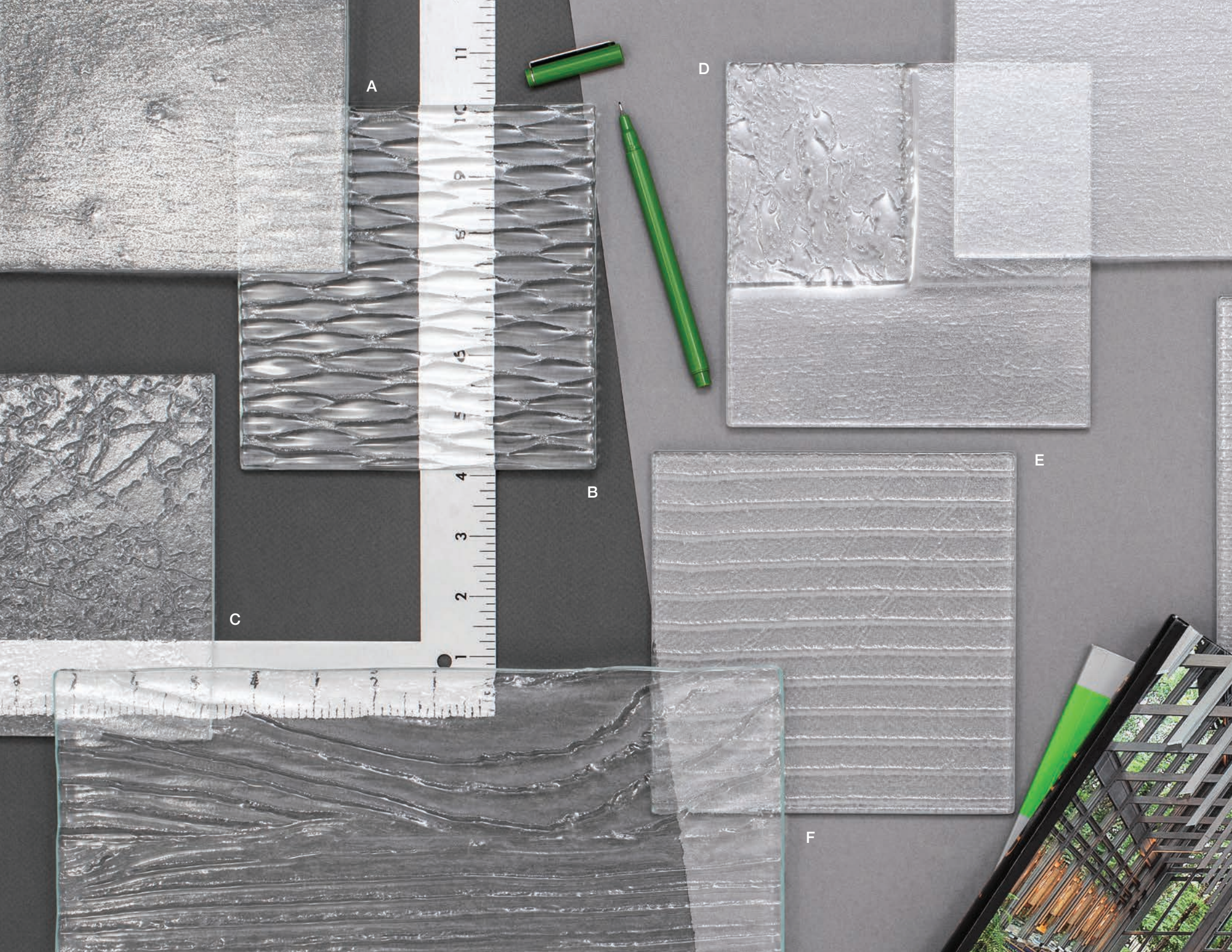

A

D

B

C

E

F



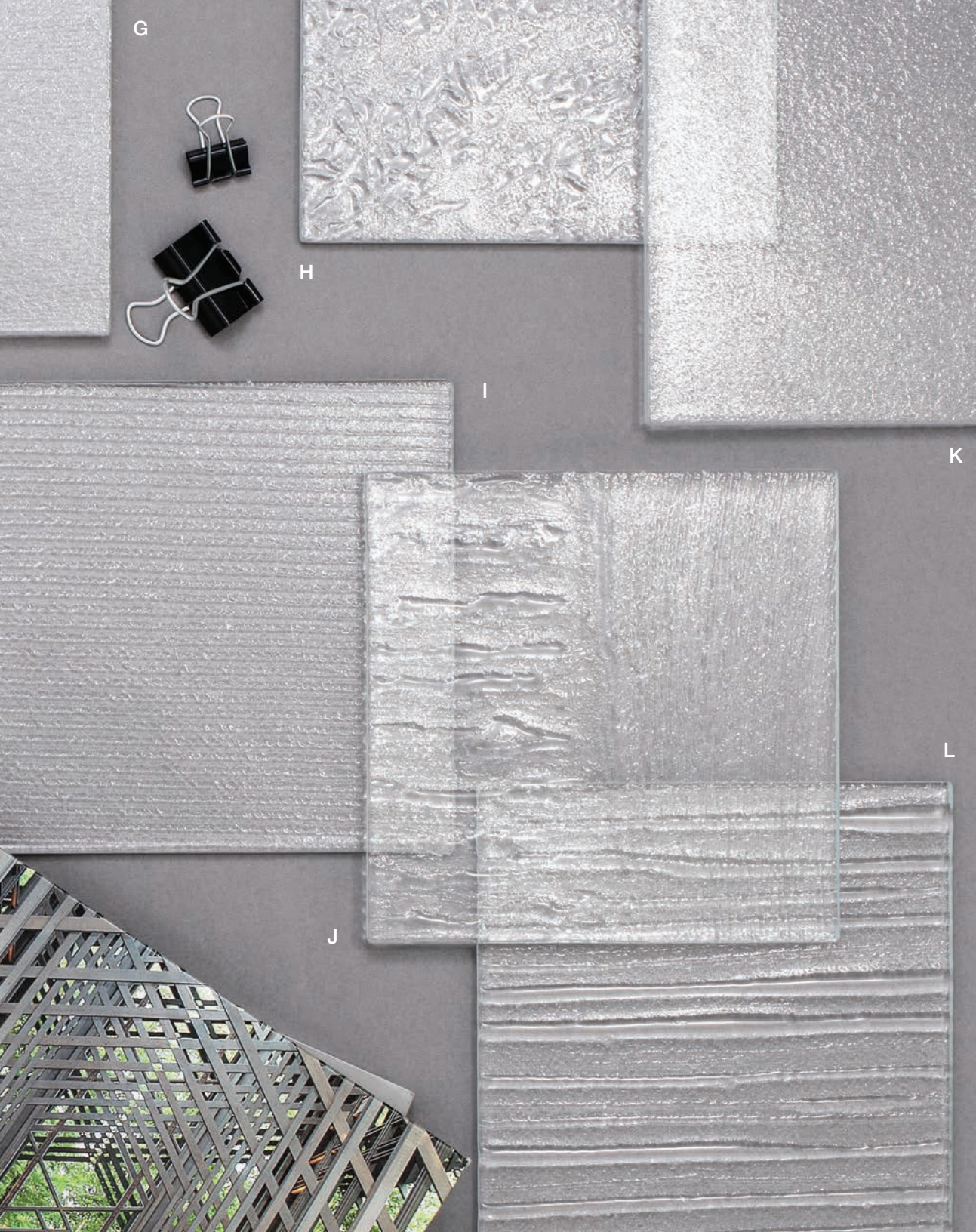

# CLASSIC KILN CAST GLASS

Classic Kiln Cast Glass features sculptural textures that are cast on hand-carved molds. Offering a timeless look and feel, these artisanal designs enhance any setting and suit glass applications of all kinds—indoors or out.

Classic glass is offered in a wide range of standard textures, each in a variety of standard glass thicknesses. While the glass is inherently transparent, surface treatments to vary opacity levels are also available.

- A. Pietra
- B. Nuv'eau
- C. Spruzzo
- D. Bricks
- E. Grande Rake
- F. Plank
- G. On-Wa
- H. Atlantis
- I. Rake
- J. Strata
- K. Valencia
- L. Hikaru



# CLASSIC KILN CAST GLASS APPLICATIONS

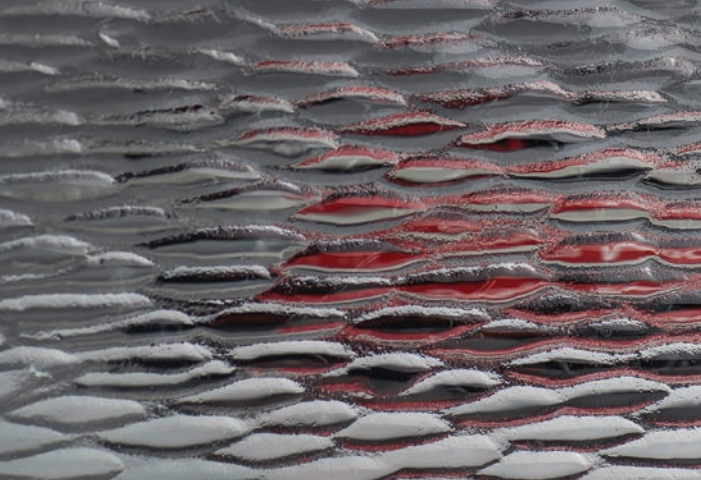

**Left:** Railing infill in Classic Kiln Cast Glass in custom texture. Washington University, Farrell Learning and Teaching Center, St. Louis, Missouri.

**Top Middle:** Classic Kiln Cast Glass in Nuv'eau texture.

**Top Right:** Classic Kiln Cast Glass in Pietra texture.

**Right:** Classic Kiln Cast Glass in On-Wa texture.

**Opposite Page:** Classic Kiln Cast Glass in Plank texture.











A



B



C



D

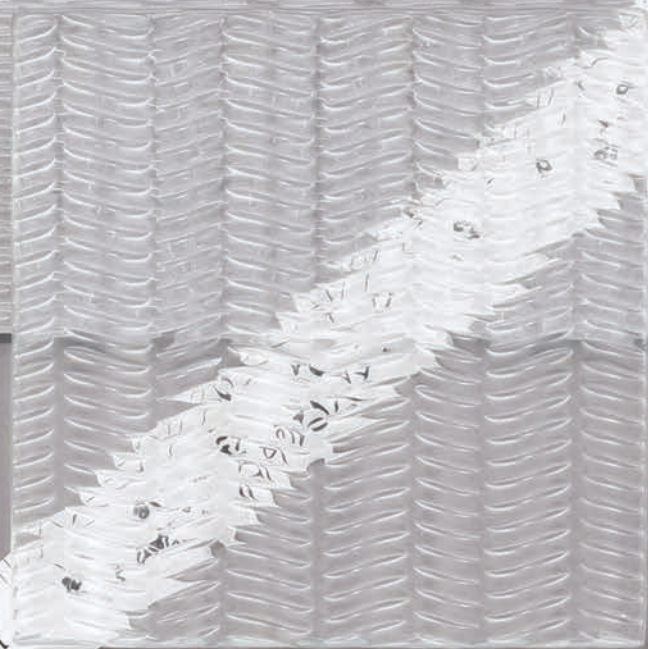





# INTERVALS KILN CAST GLASS

Intervals Kiln Cast Glass features precise, small-scale textures reminiscent of woven materials. Production innovations unique to F+S build on the artisanal heritage of kiln cast glass but propel the material forward with an infusion of geometric precision. The result: high-impact low-relief designs at an intimate, intricate scale.

Intervals glass is offered in a wide range of standard textures, each in a variety of standard glass thicknesses. While the glass is inherently transparent, surface treatments to vary opacity levels are also available.

- A. Origin
- B. Coda
- C. Locus
- D. Verse
- E. Prose
- F. Octave



# INTERVALS KILN CAST GLASS APPLICATIONS

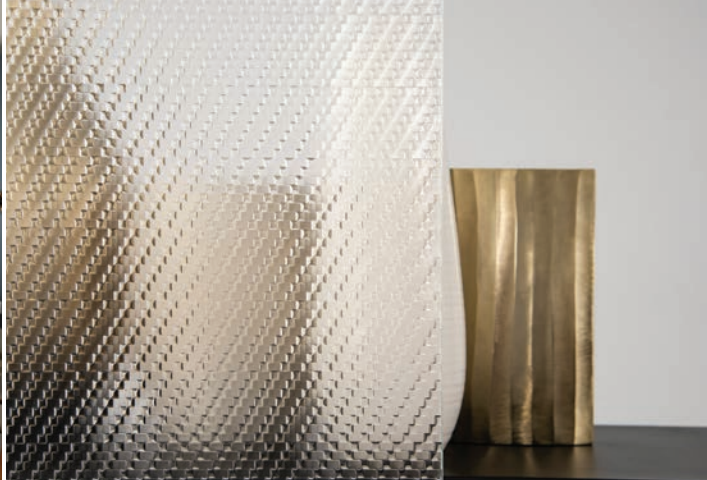

- Left:** Intervals Kiln Cast Glass in Prose texture.
- Top Middle:** Intervals Kiln Cast Glass in Locus texture.
- Top Right:** Intervals Kiln Cast Glass in Origin texture.
- Right:** Intervals Kiln Cast Glass in Prose texture.
- Opposite:** Intervals Kiln Cast Glass in Octave texture.





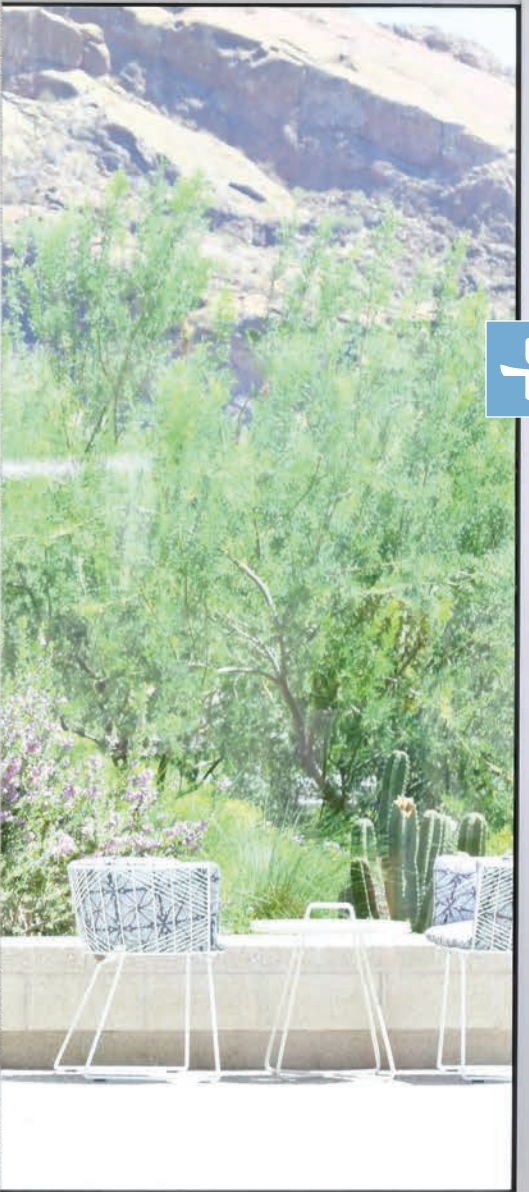



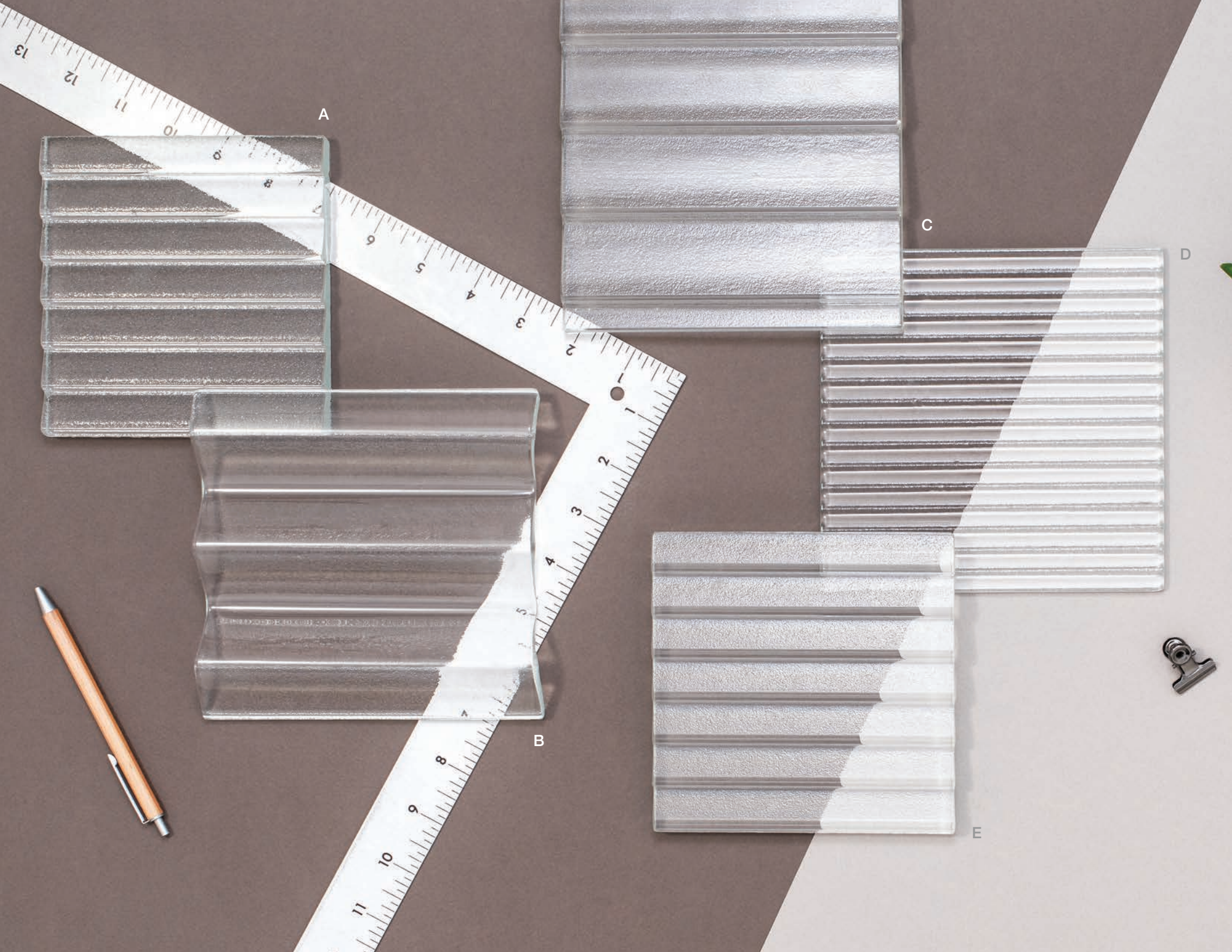

A

C

D

B

E





# PROFILE KILN CAST GLASS

Profile Kiln Cast Glass is defined by crisp linear textures. Each has its own sculptural dimensionality and some are available in vertical and horizontal orientations. Profile textures are a versatile way to bring clean linear geometry to indoor and outdoor environments.

Profile glass is offered in a wide range of standard textures, each in a variety of standard glass thicknesses. While the glass is inherently transparent, surface treatments to vary opacity levels are also available.

- A. Taglio
- B. Trio
- C. Monats
- D. Corduroy
- E. Lanto
- F. Sticks
- G. Corrugated





# PROFILE KILN CAST GLASS APPLICATIONS



**Left:** Canopy with Profile Kiln Cast Glass in Corrugated texture with custom wire interlayer. Urban Outfitters - 521 Fifth Avenue, New York, New York.

**Top Middle:** Canopy with Profile Kiln Cast Glass in Sticks texture. 25 Bond Street, New York, New York.

**Top Right:** Canopy with Profile Kiln Cast Glass in Sticks texture. 25 Bond Street, New York, New York.

**Right:** Exterior wall with Profile Kiln Cast Glass in Corrugated texture with sandblast finish. Hotel Eventi, New York, New York.

**Opposite Page:** Exterior glass panels in Profile Kiln Cast Glass in custom texture. Eleven Times Square, New York, New York.







PROSKAUER  
MICROSOFT  
SJP PROPERTIES  
ANSWERS

Proskauer»

Microsoft  
SJP PROPERTIES  
Answers







B



A





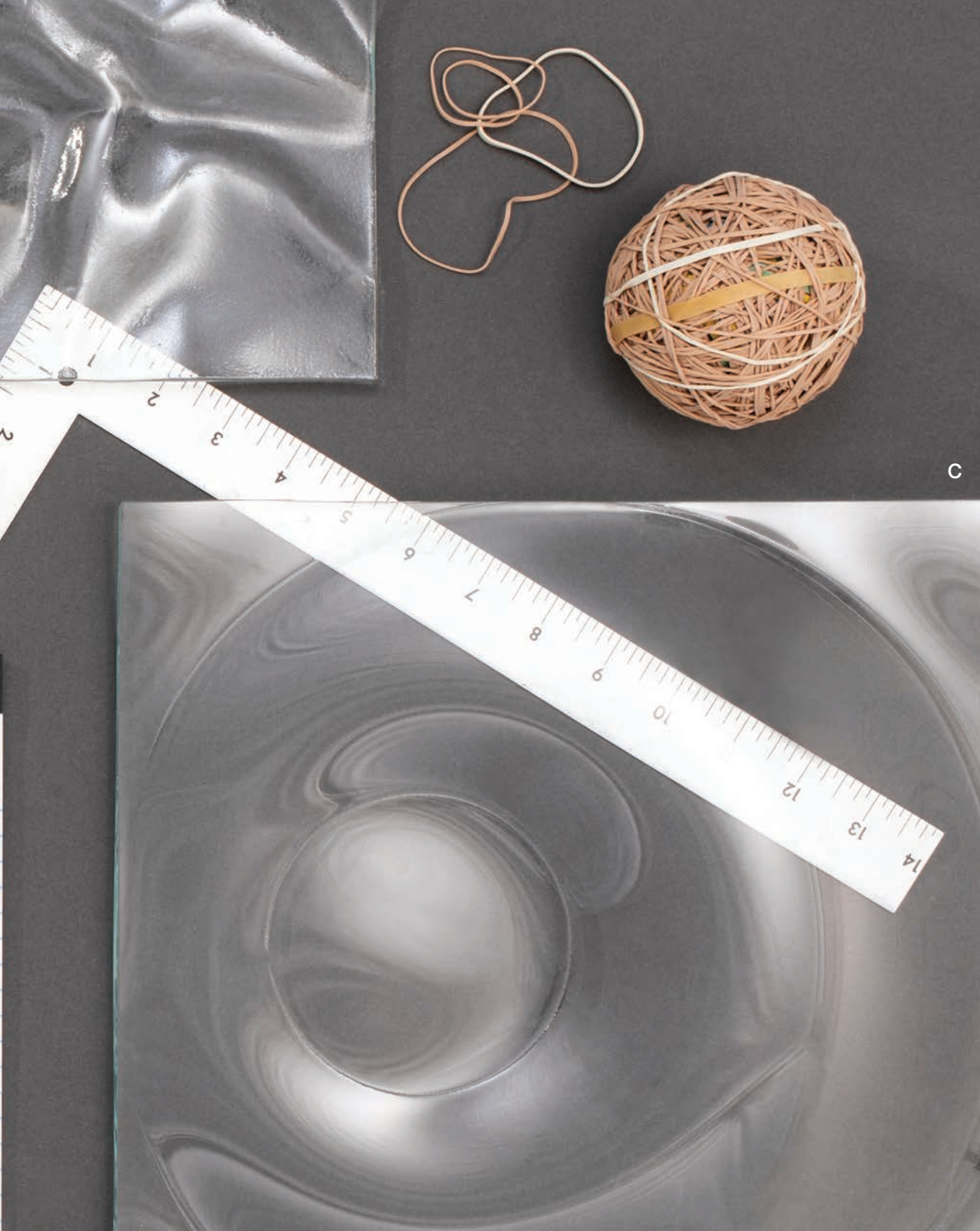

## REFRACT KILN CAST GLASS

Refract Kiln Cast Glass pushes the boundaries of 3-dimensional architectural glass. The line's artistic, deeply sculpted surfaces play with shadows and light and offer highly expressive ways to transform indoor and outdoor spaces.

Refract glass is offered in a variety of standard glass thicknesses. While the glass is inherently transparent, surface treatments to vary opacity levels are also available.

- A. Ellisse
- B. Arrigado
- C. Olivia





# REFRACT KILN CAST GLASS APPLICATIONS



- Left:** Refract Kiln Cast Glass in Ellisse texture.
- Top Middle:** Refract Kiln Cast Glass in Arrigado texture.
- Top Right:** Refract Kiln Cast Glass in Arrigado texture.
- Right:** Refract Kiln Cast Glass in Olivia texture.
- Opposite Page:** Refract Kiln Cast Glass in Ellisse texture.









A

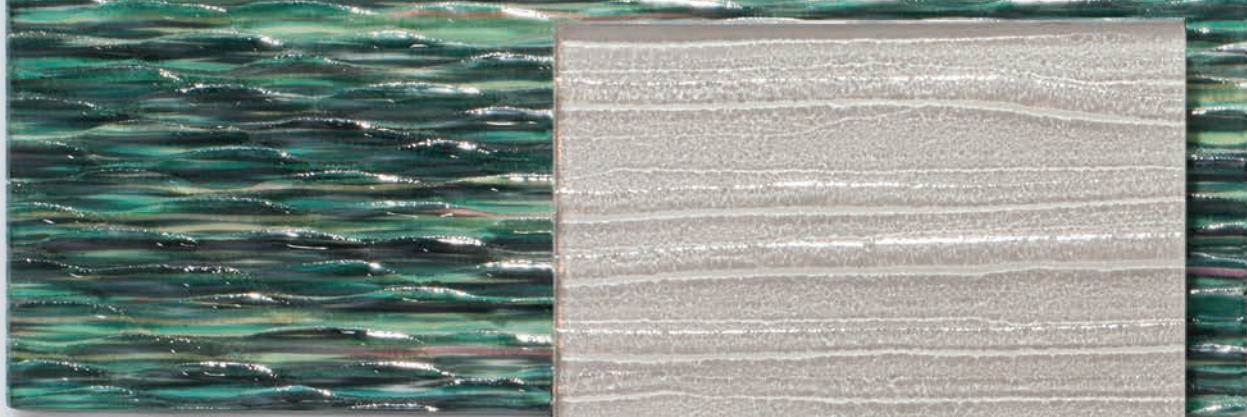

B



C



D



E



F

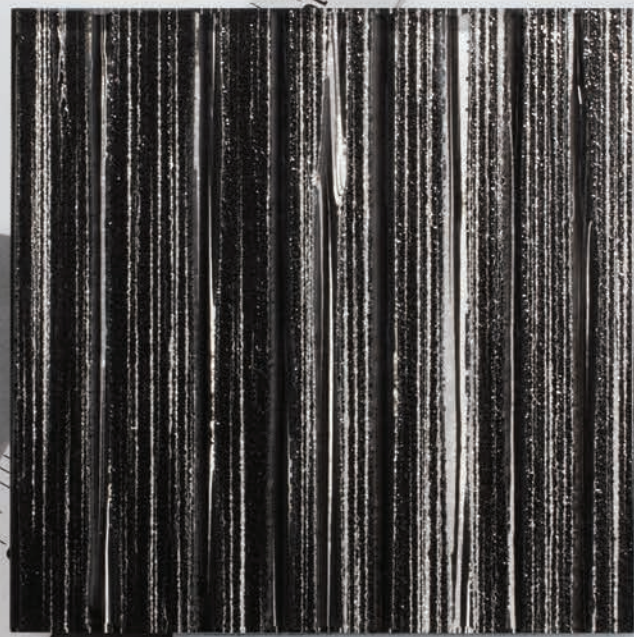





## LEVELS KILN CAST GLASS

Levels is artisanal kiln cast glass laminated with color and graphic interlayers. Each beautifully sculpted surface captures light on and through the glass. Interlayers optimized for each design add a sense of depth and dimension and accentuate ever-shifting plays of light, texture, color, and motion.

Levels Kiln Cast Glass is available exclusively in our LEVELe Wall Cladding and Column Systems, LEVELe Elevator Interiors, and LightPlane Panels.

- A. Nuv'eau + Lagoon
- B. Hikaru + Taupe
- C. Hikaru + Shimmer + White
- D. Nuv'eau + Shimmer + White
- E. Corduroy + Switchbacks + White
- F. Hikaru + Obsidian
- G. Corduroy + Shimmer + White + Graphite
- H. Corduroy + Taupe
- I. Corduroy + Caprice
- J. Hikaru + Shadow + White
- K. Nuv'eau + Shadow + White + Nickel Bronze





# LEVELS KILN CAST GLASS APPLICATIONS



**Left:** Wall panels with Levels Kiln Cast Glass in Corduroy + Shimmer design.

**Top Middle:** Levels Kiln Cast Glass in Hikaru + Taupe design.

**Top Right:** Reception desk with Levels Kiln Cast Glass in Hikaru + Taupe design.

**Right:** Levels Kiln Cast Glass in Nuv'eau + Lagoon design, shown in LightPlane Panel.

**Opposite Page:** LightPlane Panels with Levels Kiln Cast Glass in Nuv'eau + Lagoon design.











A

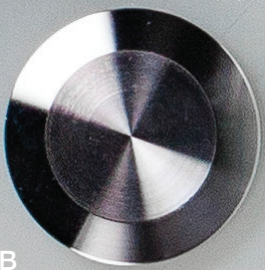

B

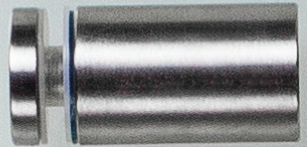

C





# GLASS HARDWARE

---

The F+S glass hardware collection gives you numerous options for installing VividGlass and BermanGlass architectural glass. The different components make it easy to address a wide range of vertical and horizontal applications and align with project design themes.

Included within this group are Edge Grip, Round, and Slot Mount standoffs, Spider Fittings, Square Mall Clamps and a Tapered Rail System.

- A. Slot Mount Standoff
- B. Spider Fitting
- C. Round Standoff
- D. Square Mall Clamp











# STAINLESS STEEL + FUSED METAL



Forms+Surfaces is among the world's premier resources for architectural stainless steel—a material unmatched in quality and beauty. Our high-durability finishes and a wide range of distinctive patterns offer limitless design and performance options for public spaces of all kinds.

Fused Metal, our exclusive line of colored stainless steel, is created using vapor deposition technology to fuse titanium alloys at the molecular level to stainless steel substrates. Fused Metal provides the durability and maintenance ease of stainless steel in a rich range of colors.





## ABOUT STAINLESS STEEL + FUSED METAL

---

Stainless steel is our flagship material. As the basis for many F+S products, it's a material that aligns with our contemporary aesthetic and one we love for its superior performance, easy maintainability, long life cycle, and high recycled content and recyclability.

It's also a material we've worked with for decades – honing our expertise across projects of all shapes and sizes, indoors and out, around the world. Our large-scale manufacturing facilities are home to sophisticated fabrication and finishing equipment. And our integrated design, engineering and project management teams are equipped with the latest tooling and technologies to ensure full coordination and quality control at every phase, from project inception to submittal package to delivery of materials at the job site.

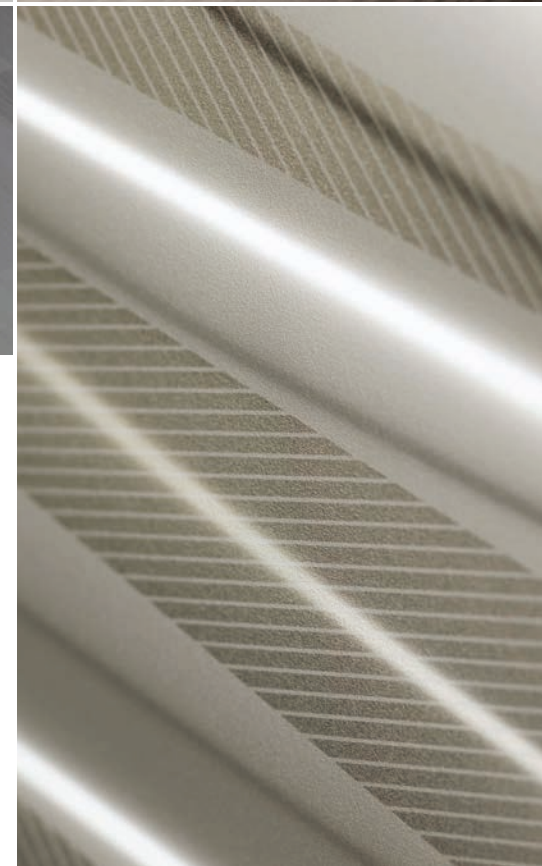
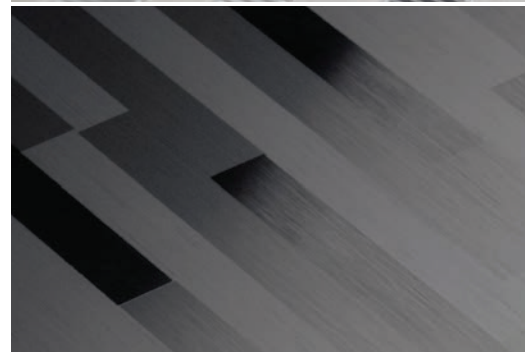



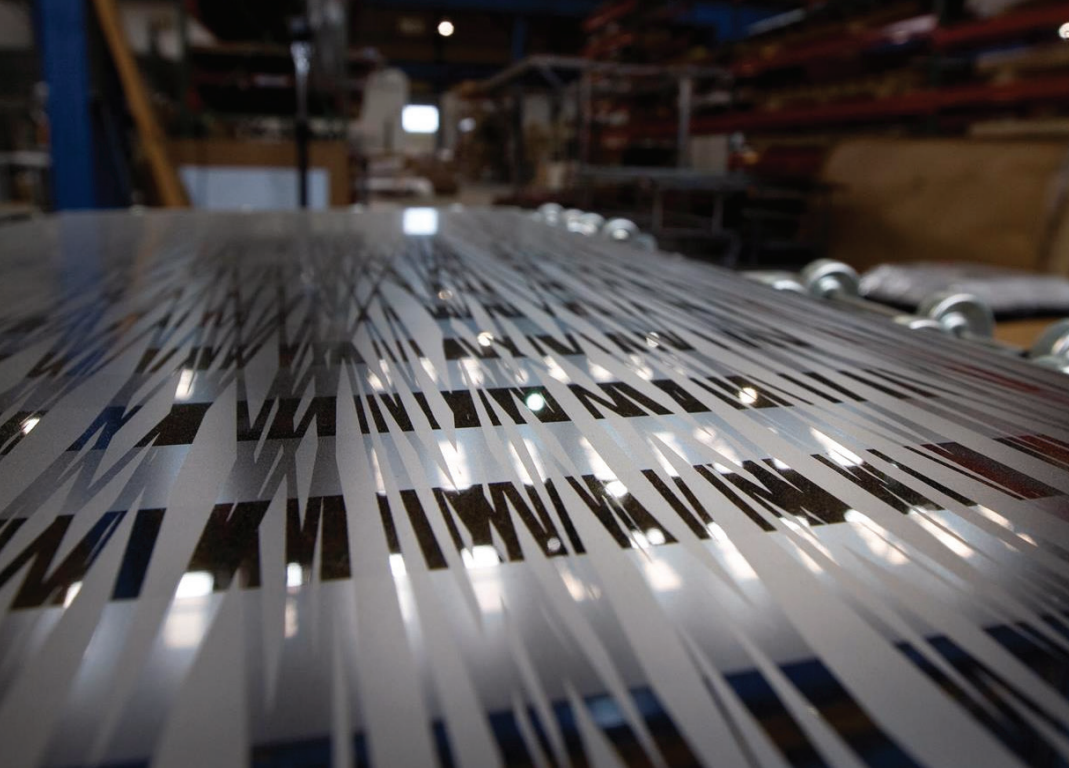

**Material** refers to the basic starting point: either stainless steel, or Fused Metal in one of several standard Fused Metal colors.

**Finish** defines each material's surface appearance. Stainless steel and Fused Metal can be specified in a variety of distinctive finishes including standard and High-Durability options. Ideal for use in high-traffic public spaces, High-Durability finishes are beautiful work-hardened surfaces with exceptional resistance to abrasion and wear.

**Patterns** are optional applied designs that add visual interest and expanded customization potential to the material/finish combination. Stainless steel and Fused Metal patterns span a wide range of aesthetics and are grouped into three broad categories: Impression, Eco-Etch and Fusion.



Fused Metal, our exclusive line of colored stainless steel, draws on this vast heritage. Fused Metal offers the performance benefits of stainless steel but moves beyond the stainless aesthetic with a rich range of colors that are beautiful on their own or as a complement to other F+S Surfaces.

Both stainless steel and Fused Metal afford numerous design and surface treatment options. Because they don't require applied finishes or coatings, we're able to let their natural beauty shine through with intrinsic finishes that allow retention of the inherent metal aesthetic; don't wear off; are non-toxic; and are available in high-durability variations that make the surfaces scratch-resistant and easier to maintain.

Stainless steel and Fused Metal are also highly configurable materials. While specific details are shown on the following pages, it will help to review three basic parameters that impact each stainless steel and Fused Metal specification: Materials, Finishes and Patterns.





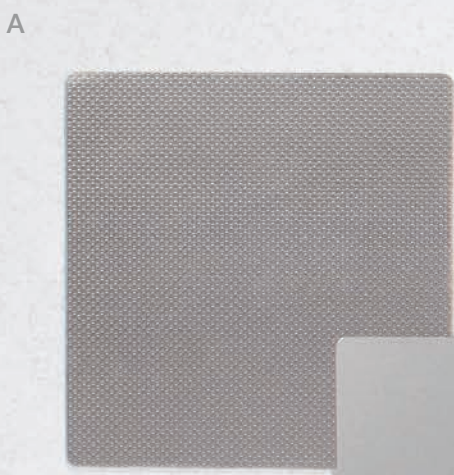



# STAINLESS STEEL FINISHES

Stainless steel is available in a variety of finishes in a choice of standard and High-Durability options.

High-Durability finishes include Silk, Sandstone, Seastone, Linen and Diamond. Standard finishes are Mist, Mirror and Satin.

- A. Stainless Steel + Silk
- B. Stainless Steel + Satin
- C. Stainless Steel + Linen
- D. Stainless Steel + Mist
- E. Stainless Steel + Seastone
- F. Stainless Steel + Diamond
- G. Stainless Steel + Sandstone
- H. Stainless Steel + Diamond
- I. Stainless Steel + Mirror
- J. Stainless Steel + Sandstone
- K. Stainless Steel + Satin

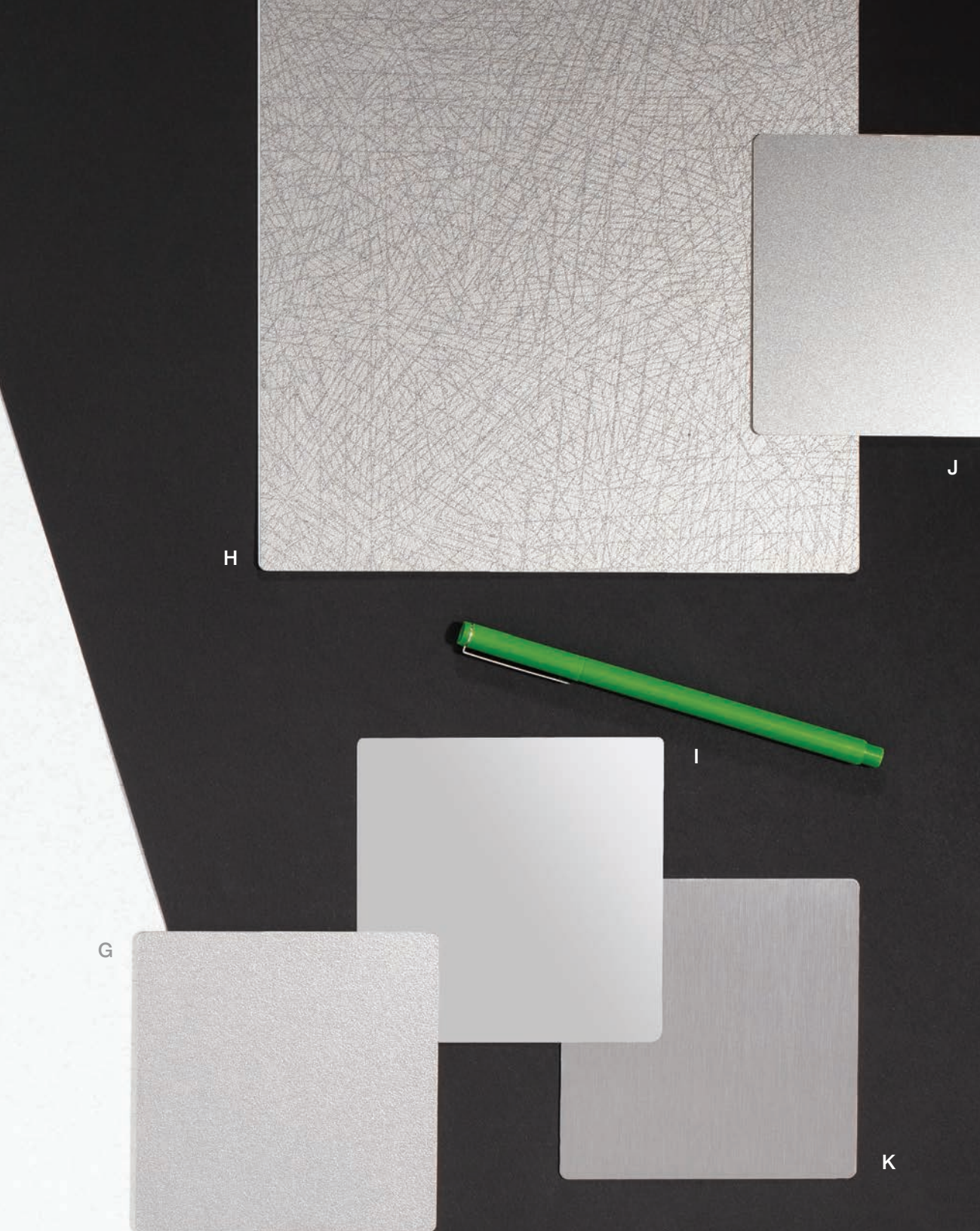





A



C



G



B



H



I



D



10

11



E

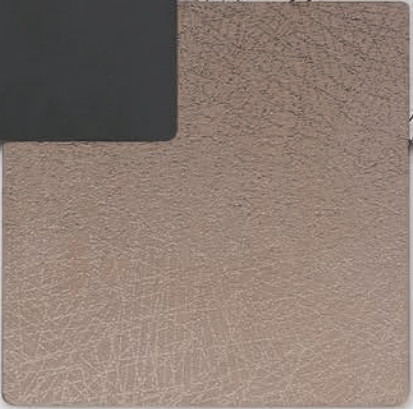

F

13

14

15

16

17

18

19

20







# FUSED METAL COLORS + FINISHES

Fused Metal is available in a variety of colors and standard and High-Durability finishes.

Fused Metal colors include Fused Bronze, Fused Graphite, Fused Nickel Bronze, Fused Nickel Silver and Fused White Gold.

High-Durability finishes include Sandstone, Seastone, Linen and Diamond. Standard finish options are Mirror and Satin.

- A. Fused Bronze + Seastone
- B. Fused Nickel Silver + Seastone
- C. Fused Nickel Silver + Diamond
- D. Fused Graphite + Mirror
- E. Fused White Gold + Linen
- F. Fused Nickel Bronze + Diamond
- G. Fused Graphite + Sandstone
- H. Fused Nickel Bronze + Satin
- I. Fused Nickel Silver + Linen
- J. Fused White Gold + Satin
- K. Fused Nickel Bronze + Linen
- L. Fused Graphite + Seastone
- M. Fused Bronze + Sandstone
- N. Fused White Gold + Mirror



A

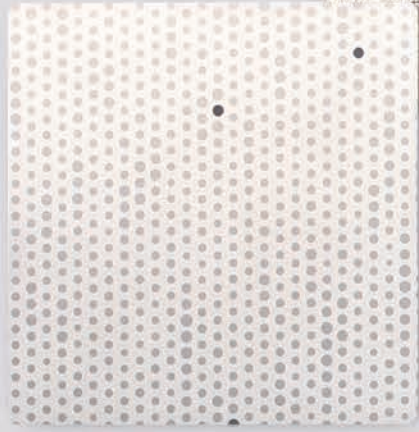

B



D

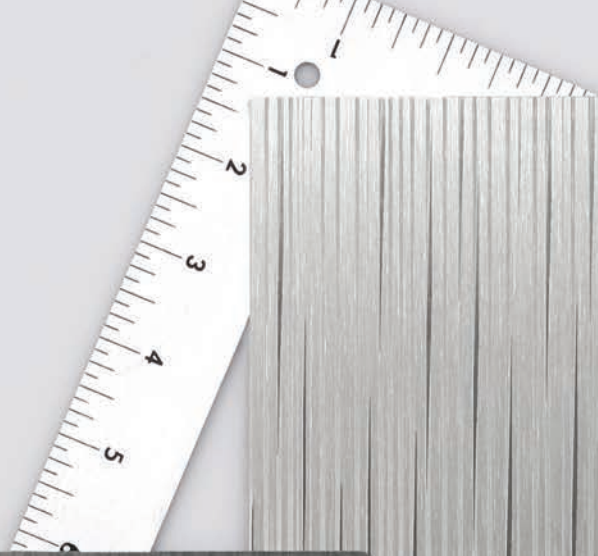

H



G

C



E

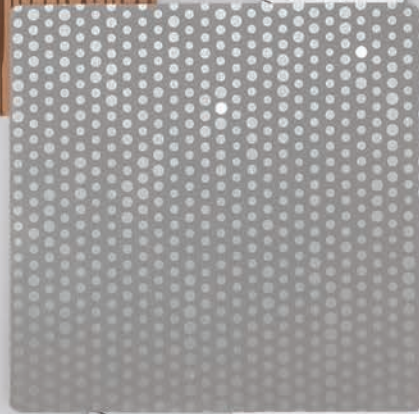

F





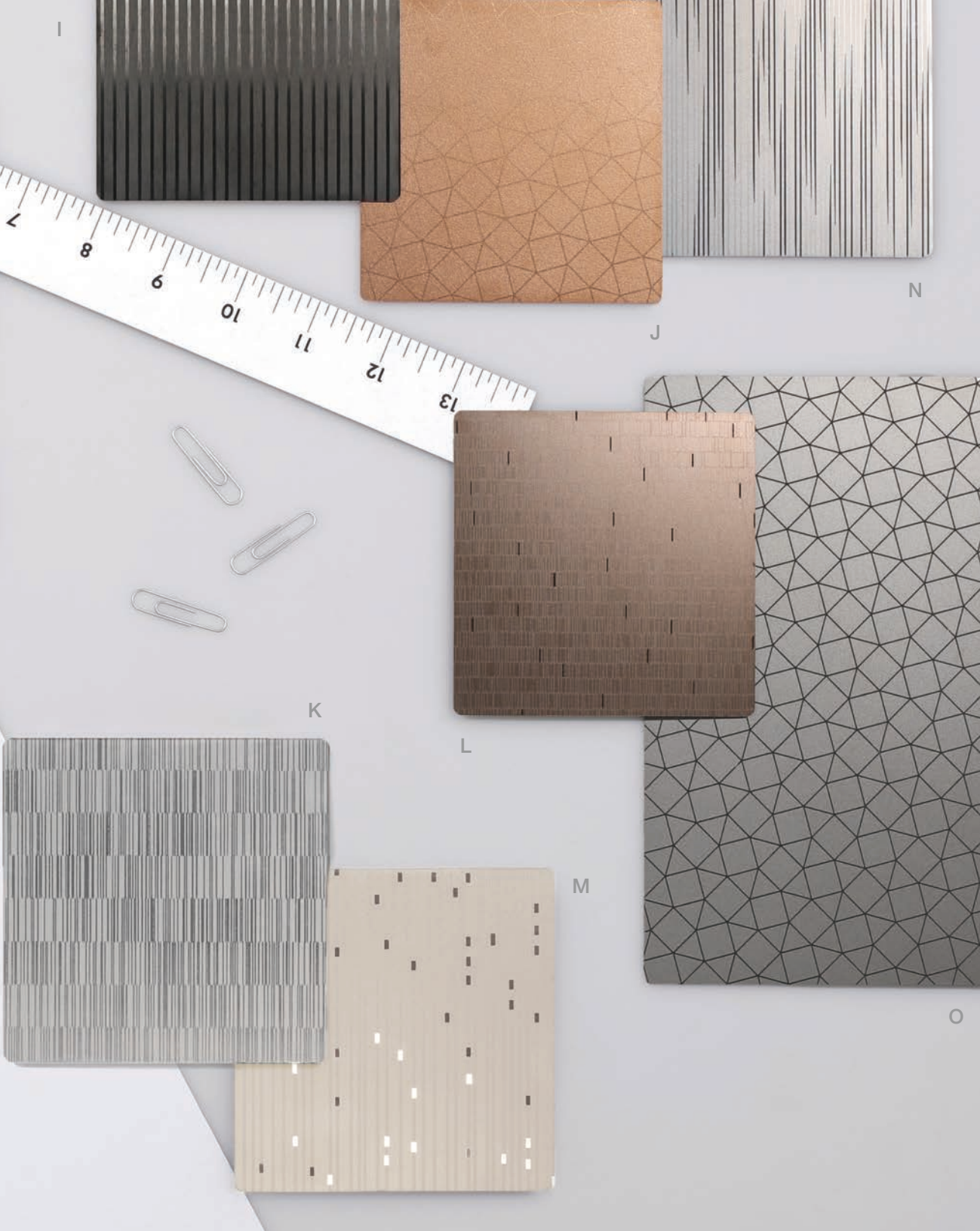

# ECO-ETCH PATTERNS

Eco-Etch patterns are eco-friendly etched designs applied to stainless steel and Fused Metal surfaces using our advanced photolithographic bead-blasting system instead of acids or harmful chemicals.

Our standard Eco-Etch patterns are only a starting point. The flexibility and speed of the Eco-Etch system afford tremendous customization potential with artwork you supply or that's developed by Forms+Surfaces.

- A. Fused White Gold + Mirror + Thatch
- B. Stainless Steel + Mirror + Flicker
- C. Stainless Steel + Satin + Stacks
- D. Stainless Steel + Satin + Glacier
- E. Fused Bronze + Mirror + Silkworm
- F. Stainless Steel + Satin + Flicker
- G. Fused Nickel Silver + Seastone + Reeds
- H. Stainless Steel + Mirror + Seagrass
- I. Fused Graphite + Satin + Stripe
- J. Fused Bronze + Seastone + Mica
- K. Stainless Steel + Satin + Sequence
- L. Fused Nickel Bronze + Mirror + Dash
- M. Fused White Gold + Mirror + City Lights
- N. Stainless Steel + Mirror + Current
- O. Stainless Steel + Mirror + Mica







A

B

C

F

D

E

G





# IMPRESSION PATTERNS

Our proprietary manufacturing capabilities include large-scale stamping equipment that can apply unique, full-press patterns across an entire sheet of material using a single tool.

The result is a series of beautiful, high-relief patterns that add visual impact, enhanced durability, and a rich, tactile feel to stainless steel and Fused Metal surfaces.

- A. Stainless Steel + Satin + Dune
- B. Stainless Steel + Sandstone + Dallas
- C. Stainless Steel + Seastone + Kalahari
- D. Stainless Steel + Seastone + Chardonnay
- E. Stainless Steel + Satin + Denver
- F. Fused Nickel Silver + Seastone + Champagne
- G. Fused Nickel Bronze + Sandstone + Dune
- H. Fused White Gold + Seastone + Dallas
- I. Fused Bronze + Seastone + Chardonnay
- J. Fused Nickel Silver + Seastone + Denver
- K. Fused Graphite + Mirror + Dallas







A



B



C



D



E



F

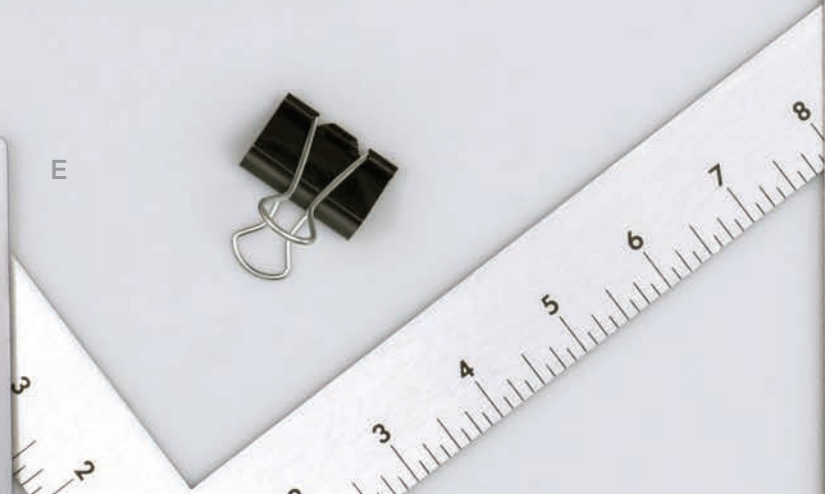





# FUSION PATTERNS

Fusion is a collection of patterns that, as the name implies, combine two or more pattern types—Etched and Impression, for example—to create unique and visually intriguing stainless steel and Fused Metal surfaces.

Fusion patterns play with shadows and light and bring an added sense of depth and dimension to the settings in which they're installed.

- A. Stainless Steel + Seastone + Cinch
- B. Stainless Steel + Seastone + Moraine
- C. Stainless Steel + Seastone + Mesa
- D. Stainless Steel + Mirror + Carbon
- E. Stainless Steel + Seastone + Moraine
- F. Fused White Gold + Seastone + Cinch
- G. Fused Bronze + Seastone + Moraine
- H. Fused Graphite + Seastone + Carbon
- I. Fused Bronze + Seastone + Cinch
- J. Fused Nickel Silver + Seastone + Moraine





# STAINLESS STEEL APPLICATIONS



**Left:** LEVELe-108 Elevator Interior with customized panel layout: Stainless Steel, Satin finish; Stainless Steel, Seastone finish; and Fused Graphite, Satin finish. Franklin Square Capital Partners, Philadelphia, Pennsylvania.

**Top Middle:** LEVELe Wall Cladding System: Stainless Steel, Seastone finish; and ViviChrome Chromis glass, custom color interlayer, Standard finish. Kossen Equipment, Inc., Jackson, Mississippi.

**Top Right:** Wall panels in Stainless Steel with Mirror finish, City Lights Eco-Etch pattern. Silvercar - DFW, Dallas, Texas.

**Right:** Column in Stainless Steel, Seastone finish. Nationwide Children's Hospital - Research Building III, Columbus, Ohio.

**Opposite Page:** LEVELe Wall Cladding System with Stainless Steel, Seastone finish. Chicago Board of Trade, Chicago, Illinois.





 A vertical panel of three screens. The top screen shows a news broadcast with the text "NEW DEBATE OVER CONFEDERATE FLAG ON STATE HOUSE GROUNDS". The middle screen shows a boat on a body of water. The bottom screen features a "BUSINESS ALERT" graphic.

 A large central panel with a blue background. The main text reads "America's TOP STATES FOR BUSINESS" in a stylized, glowing font. Below this, it says "WEDNESDAY 8A-9A ET" and "STARTING IN SQUAWK BOX 6A ET". At the bottom, there is a financial ticker with the following data:

WTI (Jul)	59.34	BRENT (Aug)	62.72	NAT GAS (Jul)	2.733
AJ	21.86 ▲ 0.01	C.H. Robinson (CHRW)	54.42 ▲ 0.21	Avago Technology	33.15

 A vertical panel of three screens. The top screen shows a news broadcast. The middle screen shows a person's face. The bottom screen shows a news broadcast with a person's face.





# FUSED METAL APPLICATIONS



**Left:** Elevator doors in Fused Bronze, Satin finish, custom Eco-Etch pattern. New York Life Insurance, Dallas, Texas.

**Top Middle:** LEVELe Wall Cladding System with Fused White Gold, Seastone finish, Kalahari Impression pattern. Fountain Place, Dallas, Texas.

**Top Right:** LEVELe Wall Cladding System with Fused Nickel Silver, Linen finish. Texas Life Insurance, Waco, Texas.

**Right:** LEVELe-104 Elevator Interior: Stainless Steel, custom finish; and Fused Graphite, Mirror finish, custom Eco-Etch pattern. Metropolitan Bank Mississippi Headquarters, Ridgeland, Mississippi.

**Opposite Page:** Wall panels in Fused White Gold, Seastone finish. University of Chicago - Saieh Hall for Economics, Chicago, Illinois















# LINQ WOVEN METAL



Linq Woven Metal brings a distinctly F+S twist to woven metal. Shaped by innovative design and material capabilities exclusive to Forms+Surfaces, Linq unites modern aesthetics, exceptional durability, and full integration with our wall systems, columns, elevator interiors and more.

Linq patterns consist of flat and/or round wires interwoven to create distinctive textures and designs. The patterns emphasize stainless steel, though brass is available for select patterns.



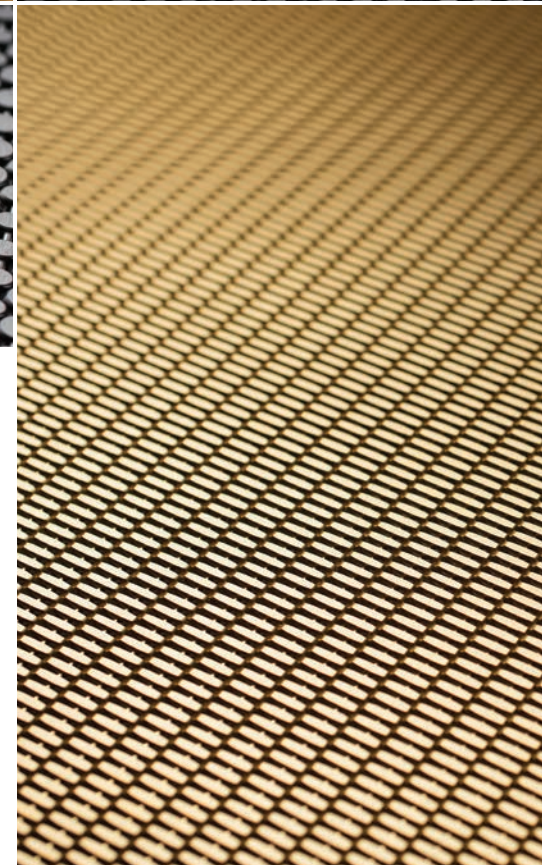
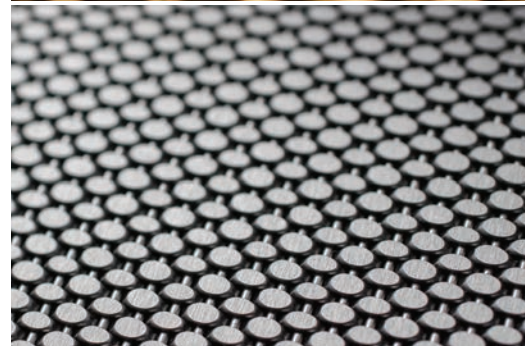
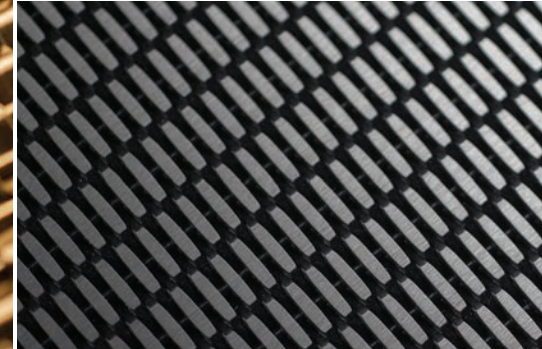
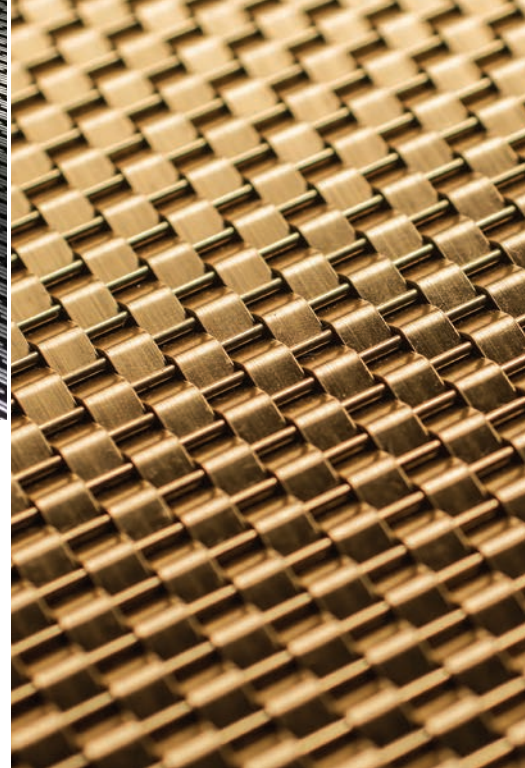

## ABOUT LINQ WOVEN METAL

---

Linq Woven Metal represents our latest foray into giving you new ways to bring dynamic metal surfaces to architectural settings.

Linq unites two F+S traditions. The first draws on our extensive history working with stainless steel and other architectural metals. The second reflects our ongoing commitment to product and material innovation; in this case: folding an outsourced material into our mix and giving it a Forms+Surfaces twist.

Woven metal also has its own long tradition. Known originally for its use in industrial applications, it has a reputation in the architectural arena as well, where its versatility, beauty and durability span a range of uses, from wall cladding and space dividers to counter fronts, railings, and more.





All Linq patterns are available as standard panel inset options for our LEVELe Wall Cladding, Column and Elevator Interior Systems. This integration makes working with woven metal – a material that’s often hard to work with – a simple and attractive proposition.

When Linq is specified in F+S Systems, we control the entire fabrication process. This ensures consistent quality throughout each step and a higher quality outcome. And, because we do it all, the end results are more cost-efficient than pairing woven metal from one source with the panel and trim solutions of another.

With F+S Systems and Linq, you can confidently and creatively incorporate the beauty of woven metal into your projects.



Linq Woven Metal offers an updated alternative to more familiar woven metal designs – a welcome development for a material that hasn’t seen much visual evolution in recent years.

The different Linq weaves, wire thicknesses, and metal combinations yield a wide range of end results. Each pattern plays with light in its own unique way. As illumination from surrounding sources washes over the textured surfaces, patterns appear to shift and change.

Linq is an ideal solution for high-traffic public spaces. The woven materials – stainless steel and other metals – are durable in their own right. The patterns they create help hide scratches and dents.

Linq is also highly adaptable. It’s appropriate for use indoors or out. And its jewelry-like textures make it a beautiful choice for applications of all sizes, from feature walls to high-impact accents and details.

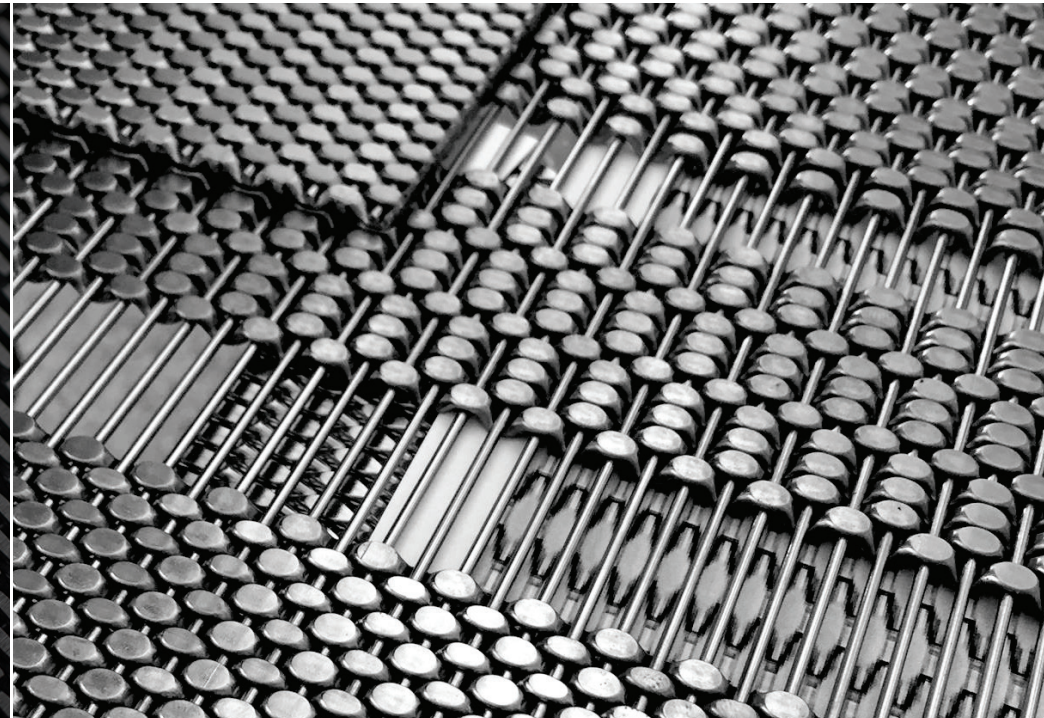





A

B

F

G

C

D

E

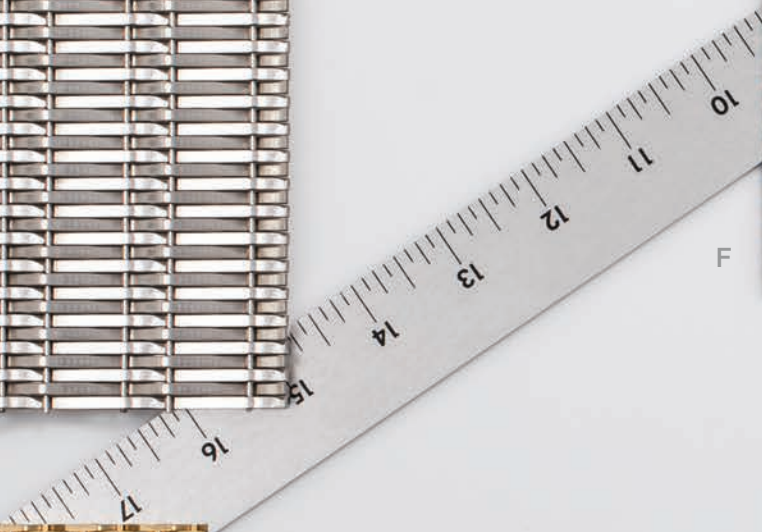
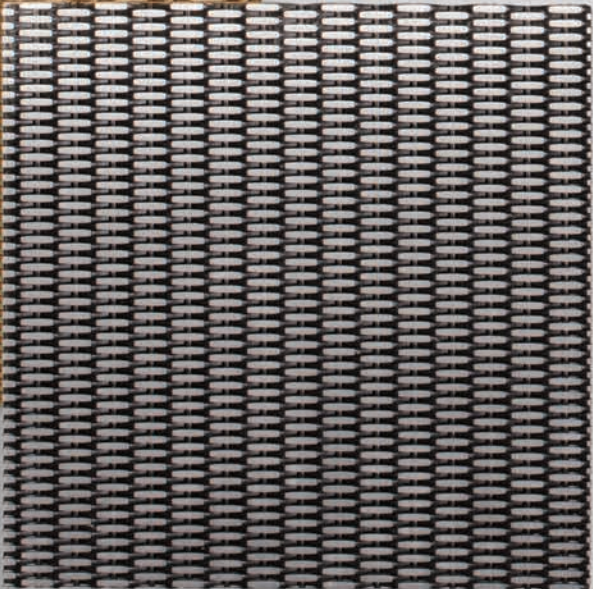
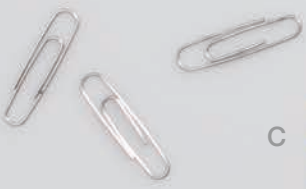
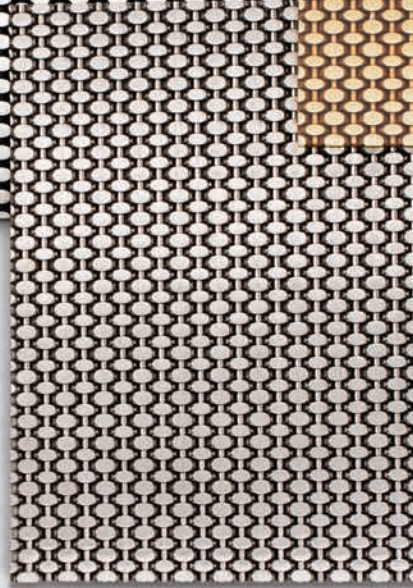
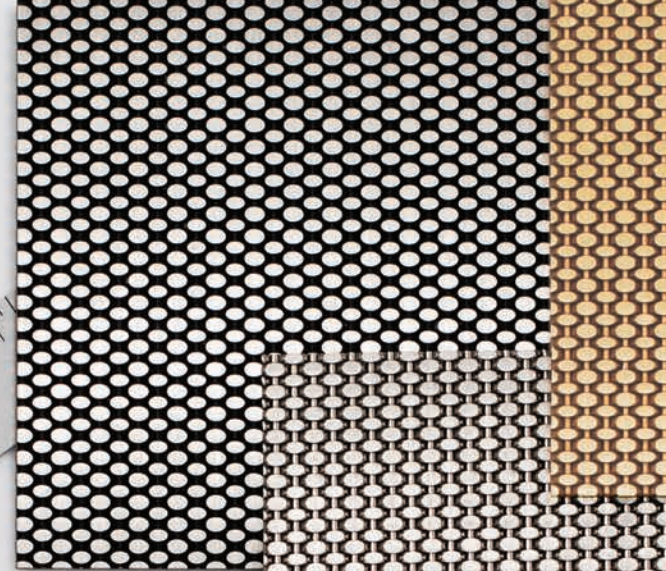
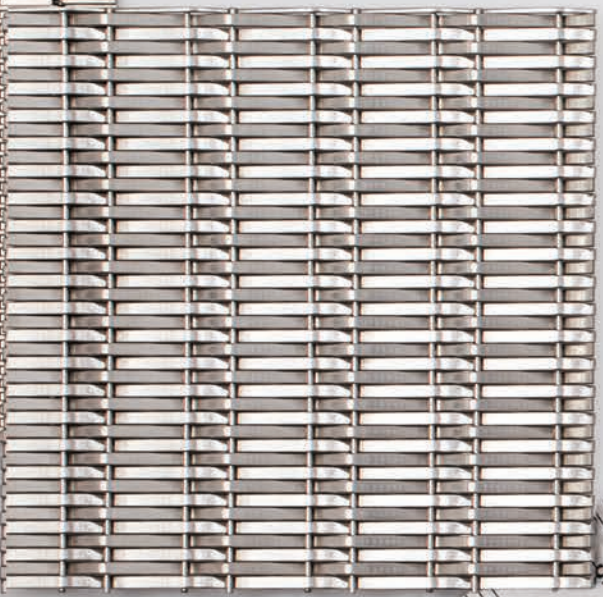





# LINQ WOVEN METAL

Linq selections are defined by three basic parameters:

1. Material refers to the metal wire used. All patterns are available in Stainless Steel. Select patterns are available in Brass.
2. Patinas are contrast-enhancing surface treatments applied to the woven metal. Select Linq patterns are available with a Dark patina.
3. Patterns are the distinctive textures or designs created by weaving the metal. Patterns consist of flat and/or round wires interwoven to create distinctive, rigid textures and designs.

- A. Stainless Steel + Echo
- B. Stainless Steel + Slope
- C. Brass + Merge
- D. Stainless Steel + Merge
- E. Stainless Steel + Dark + Merge
- F. Stainless Steel + Dark + Sum
- G. Stainless Steel + Sum
- H. Brass + Sum
- I. Stainless Steel + Wave
- J. Stainless Steel + Rhythm
- K. Brass + Wave





# LINQ WOVEN METAL APPLICATIONS



**Left:** LEVELe-104 Elevator Interior: custom wood veneer; Fused Graphite, Seastone finish; and Linq Woven Metal with Sum CrossLinq pattern in Stainless Steel.

**Top Middle:** LEVELe-105 Elevator Interior: ViviStone Honey Onyx glass, custom interlayer; Linq Woven Metal with custom Crosslinq pattern in Brass; Fused Bronze, Satin finish. Park Central Hotel, New York, New York.

**Top Right:** LEVELe-106 Elevator Interior with customized panel layout: Linq Woven Metal with custom CrossLinq pattern in Stainless Steel and Brass; ViviSpectra Elements glass, Highlight interlayer, Standard finish. 7600 West Tidwell Road, Houston, Texas.

**Right:** LEVELe-106 Elevator Interior with customized panel layout: Linq Woven Metal with custom CrossLinq pattern in Stainless Steel and Brass; ViviSpectra Elements glass, Highlight interlayer, Standard finish. 7600 West Tidwell Road, Houston, Texas.

**Opposite Page:** LEVELe-104 Elevator Interior: ViviSpectra Elements glass, White Marble, Pearlex finish; ViviSpectra Spectrum glass, custom image interlayer, Pearlex finish; and Linq Woven Metal with Sum CrossLinq pattern in Stainless Steel. Kenmawr Apartments, Pittsburgh, Pennsylvania.









ELEVATOR VESTIBULE  
Dedicated to  
CHRISTOPHER W. KABLER







# BONDED METAL



Bonded Metal has achieved a place of distinction among high-performance surfacing materials. Providing a striking breadth of design possibilities, Bonded Metal is the product of a unique technology that casts metal granules in a tough, FRP matrix. Advanced mold-making techniques ensure perfect reproduction of every fine detail in the original patterned surface. The result is lightweight but extremely durable castings with the character and appearance of solid metal. Bonded Metal can be specified for walls, doors, elevators, accents or any application where visual richness and exceptional resistance to wear are requirements. Field-proven for more than 50 years, Bonded Metal is exclusive to Forms+Surfaces.



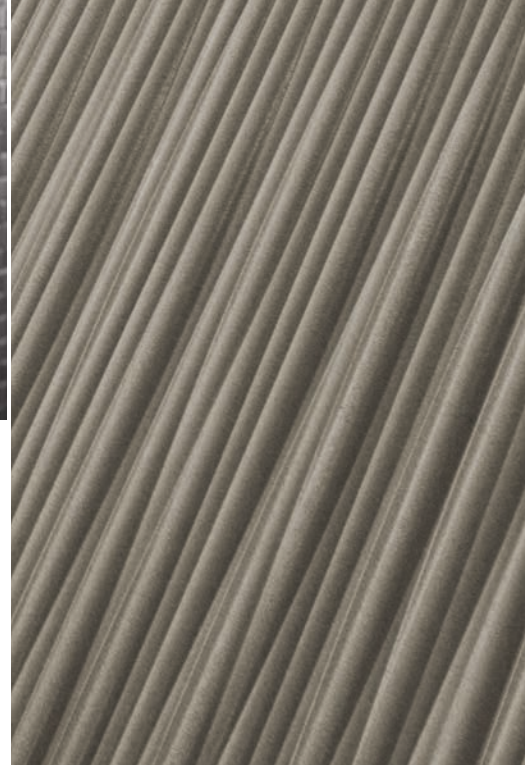

## ABOUT BONDED METAL

---

The story of Bonded Metal begins in the late 1960s, with a step back to 1963 when our company founder created a carved wood door as an “extra touch” for a condominium he owned. Prompting enthusiastic response, that carved wood door turned into many and his new business – Panelcarve – was born.

Soon after, a trip to Italy took him and his artist wife to a Florence foundry to explore ideas for door pulls to complement the carved wood doors. They cast their most promising designs in bronze and returned with them to their studio in California. These became the patterns for their new line of cast door pulls.

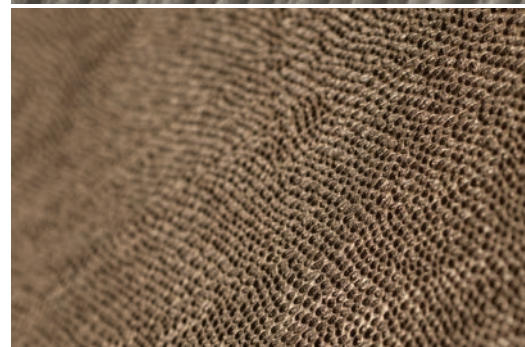





Bonded Bronze has evolved over the years. The line is now known as Bonded Metal – reflecting the addition of metals other than bronze. Pattern and application options have also grown and diversified.

The finished results, however, remain much as they've always been: extremely durable, lightweight castings with the character and appearance of solid metal.

We continue exploring new directions for this time-proven material. New technologies, and our in-house design and production teams, drive creative advances that help ensure that today's Bonded Metal retains the authentic beauty of the ten hand-crafted designs produced half a century ago.

Casting door pulls led to casting aluminum wall tiles. But these were heavy and expensive to produce so the couple used their next trip to Europe to search for lighter weight, less expensive ways to obtain metallic wall surfaces.

The solution came through a craftsman in England: he had a process for making wall panels using a "cold cast" method in which polyester resin was combined with bronze powder in a fiberglass-reinforced mix. The completed panels were light in weight and looked like bronze.

The results were inspiring and drove further collaborations back in California. From there, ten original wall panel designs were crafted in clay as patterns for what would become Forms+Surfaces' newest and ultimately, most enduring material: Bonded Bronze.

This revolutionary product went to market in 1969 for use on walls and doors. Other applications, including elevator interiors, came later.





A

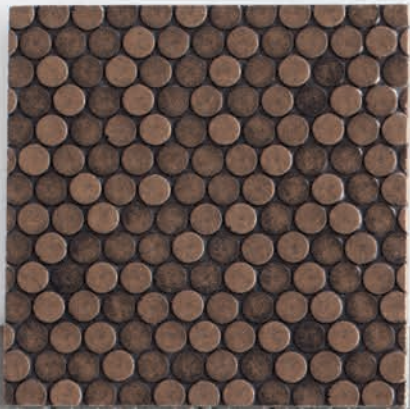

B



D

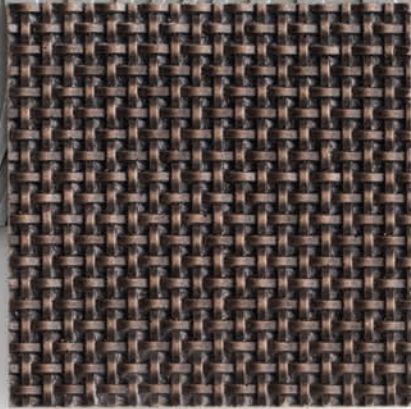

G

C



E



F







# BONDED METAL

Bonded Metal selections are defined by three basic parameters:

1. Colors are established by the metal incorporated into the Bonded Metal matrix.
2. Patinas are a contrast-enhancing treatment applied to the Bonded Metal surface.
3. Patterns are the distinctive texture or design cast into the Bonded Metal surface.

Color options include Bonded Aluminum, Bonded Bronze and Bonded Nickel Silver; patina options are Natural or Dark. Most Bonded Metal patterns are available in all color/patina combinations.

- A. Bonded Bronze + Dark + Trevia
- B. Bonded Aluminum + Natural + Undercurrent
- C. Bonded Nickel Silver + Natural + Terrane
- D. Bonded Aluminum + Natural + Sahara
- E. Bonded Bronze + Natural + Champagne
- F. Bonded Aluminum + Natural + Waterfall
- G. Bonded Bronze + Dark + Charleston
- H. Bonded Bronze + Dark + Glint
- I. Bonded Nickel Silver + Natural + Kalahari
- J. Bonded Aluminum + Dark + Grass
- K. Bonded Aluminum + Dark + Talus





A



D



B



E



G

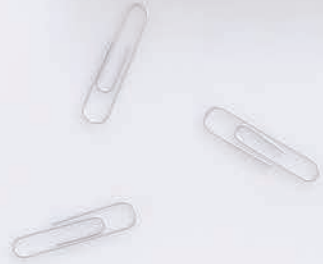

F

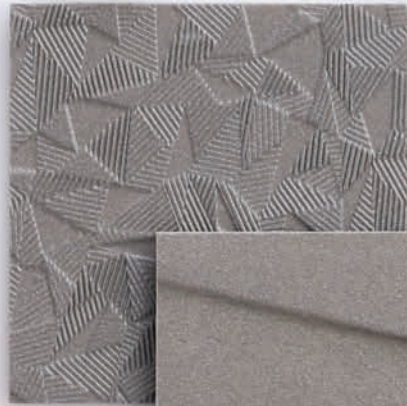

H



C





# BONDED METAL

- A. Bonded Bronze + Natural + Glint
- B. Bonded Nickel Silver + Natural + Herringbone
- C. Bonded Nickel Silver + Natural + Mara
- D. Bonded Bronze + Dark + Austin
- E. Bonded Nickel Silver + Dark + Rain
- F. Bonded Nickel Silver + Natural + Tilt
- G. Bonded Nickel Silver + Natural + Loft
- H. Bonded Nickel Silver + Natural + Chardonnay
- I. Bonded Bronze + Natural + Kalahari
- J. Bonded Bronze + Dark + Delta
- K. Bonded Aluminum + Dark + Dash
- L. Bonded Nickel Silver + Dark + Vancouver





# BONDED METAL APPLICATIONS



**Left:** LEVELe-107 Elevator Interior: Bonded Nickel Silver, Dark Patina, Vancouver pattern; Stainless Steel, custom finish; and ViviChrome Chromis glass, Taupe interlayer, Opalex finish. Private location, Brentwood, Tennessee.

**Top Middle:** Wall panels in Bonded Aluminum, Natural Patina, Herringbone pattern. 515 North State Street, Chicago, Illinois.

**Top Right:** Door in Bonded Bronze, Dark Patina, Herringbone pattern. Private residence, Bangalore, Karnataka, India.

**Right:** LEVELe-107 Elevator Interior: LightPlane panels in ViviSpectra Elements glass, Yucca interlayer, Pearlex finish; insets in Bonded Bronze, Dark Patina, Trevia pattern. 1520 & 1528 Woodward Avenue, Detroit, Michigan.

**Opposite Page:** LEVELe Wall Cladding System: Bonded Aluminum, Dark Patina, Loft pattern; and Stainless Steel, Diamond finish. NAV Consulting, Oakbrook Terrace, Illinois.









**SPAZIO**

DELL





# BONDED QUARTZ



Bonded Quartz is a high-performance surfacing solution ideal for today's interior spaces. Unlike anything else on the market, Bonded Quartz incorporates ceramic microspheres in a fiber-reinforced polymer matrix. This combination yields incredibly durable, lightweight castings that have a stunning surface appearance and are easy to clean. The standard colors for Bonded Quartz are White and Charcoal; custom colors are also an option. Bonded Quartz is ideal for use on walls, columns, elevator interiors, counter facings and other applications where visual richness is desired.



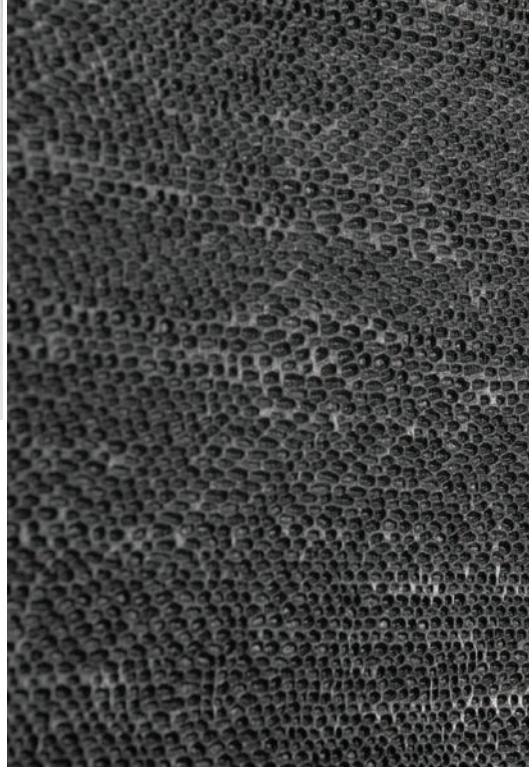

## ABOUT BONDED QUARTZ

---

Bonded Quartz was developed by the Forms+Surfaces Design Studio as a modern, high-performance vertical surfacing solution. Bonded Quartz draws on our long history of mold-making and material casting, and the expertise gained through decades of working with Bonded Metal.

Rather than being a direct translation of Bonded Metal, Bonded Quartz was created to optimize the visual qualities and surface characteristics of this unique material. In some cases there's overlap – some patterns are available in both Bonded Quartz and Bonded Metal – while others are material-specific. Even within the Bonded Quartz line, not all patterns are available in both standard colors.

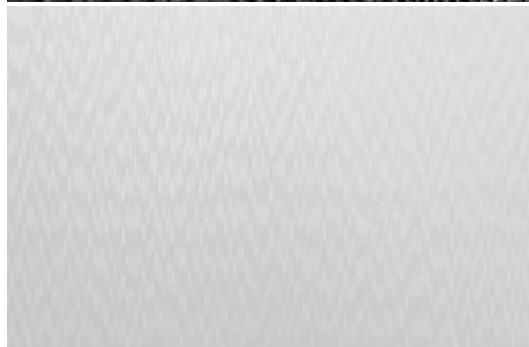





Bonded Quartz is ideal for use on walls, wainscoting, counter facings, doors, or any interior vertical surfacing application where visual richness is desired.

As with the majority of our Surfaces, Bonded Quartz castings can be specified in sheet sizes that let you move from architectural accents to applications of monolithic proportions.

Bonded Quartz can also be incorporated into many of our Systems products, including LEVELe Wall Cladding, Column and Elevator Interior Systems.

For expanded visual reach, some Bonded Quartz patterns are available in both horizontal and vertical orientations.

Bonded Quartz patterns range from intricate textures to refined geometrics to designs that echo nature and everyday life. Each pattern is carefully considered for its ability to capture shadows, direct light, and bring dimension to the beautiful monochromatic surfaces. No matter how simple or detailed the pattern, each Bonded Quartz casting is precisely output from its mold.

The standard Bonded Quartz color palette departs from the metallic nature of Bonded Metal and keeps things simple with deep Charcoal and crisp White. Custom colors are also an option on a per-project basis. As with Bonded Metal, all color is integral, so scratches or blemishes are far less noticeable than in materials with surface-applied finishes.







A

B

C

E

F

D



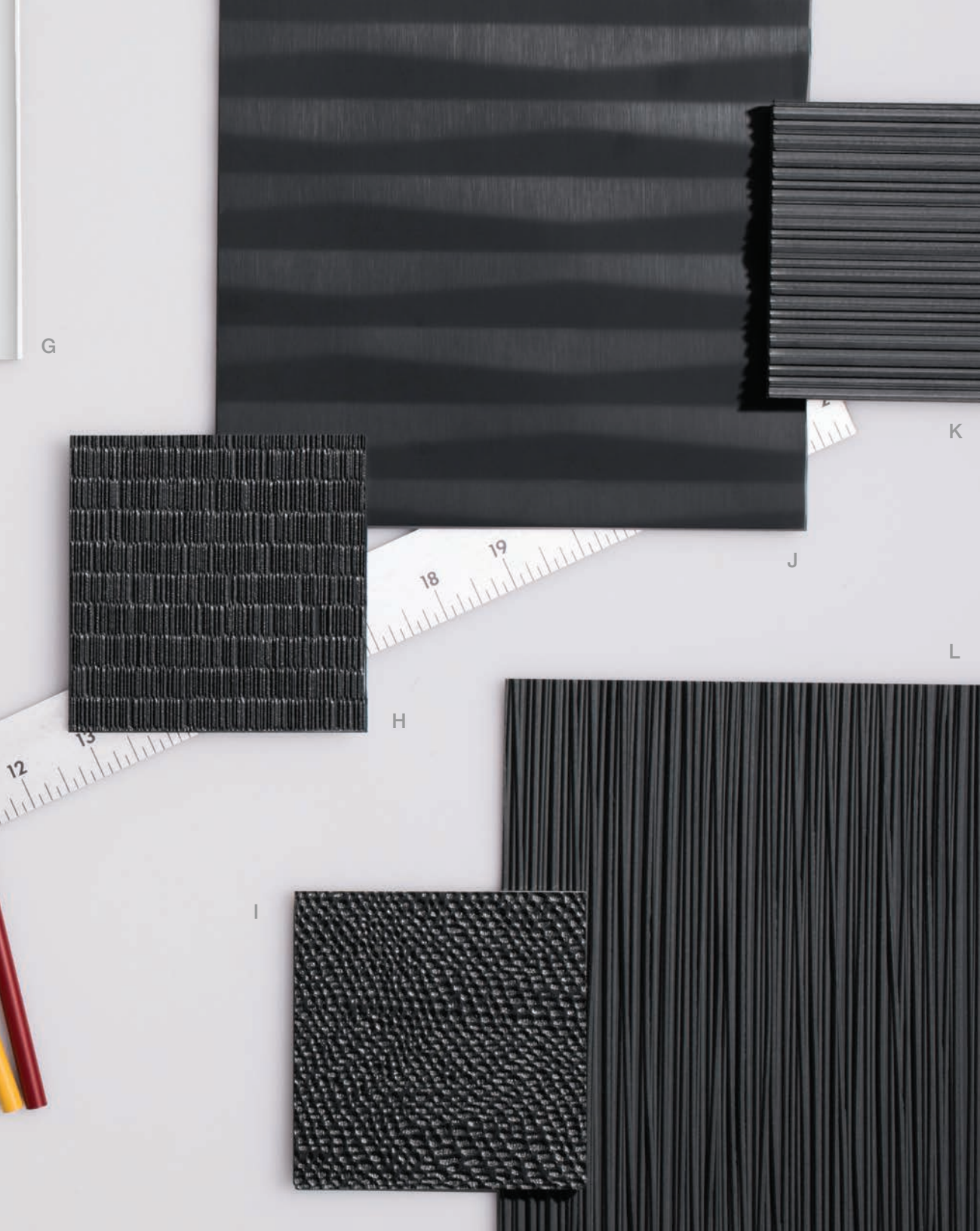

# BONDED QUARTZ

Bonded Quartz selections are defined by two basic parameters:

1. Colors include the two options shown here. Both are integral to the castings so scratches and blemishes are far less apparent than with surface-applied color finishes.
2. Patterns are the distinctive texture or design cast into the Bonded Quartz surface.

Some Bonded Quartz patterns can be specified in both Charcoal and White; others are available in only one of the two colors.

- A. Bonded White + Current
- B. Bonded White + Glint
- C. Bonded White + Waterfall
- D. Bonded White + Dash
- E. Bonded White + Grass
- F. Bonded White + Carbon
- G. Bonded White + Mara
- H. Bonded Charcoal + Dash
- I. Bonded Charcoal + Glint
- J. Bonded Charcoal + Carbon
- K. Bonded Charcoal + Loft
- L. Bonded Charcoal + Grass







A



B



C



D

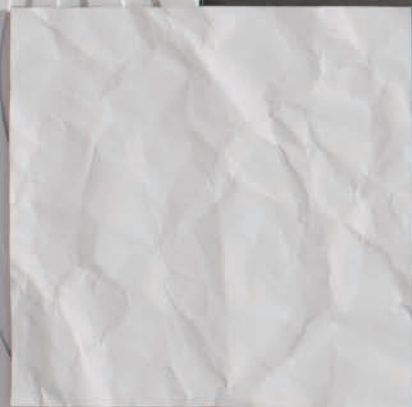

E



F



H



G



A





# BONDED QUARTZ

---

- A. Bonded White + Tilt
- B. Bonded White + Trevia
- C. Bonded White + Kalahari
- D. Bonded White + Sahara
- E. Bonded White + Crinkle
- F. Bonded White + Loft
- G. Bonded White + Dune
- H. Bonded Charcoal + Dune
- I. Bonded Charcoal + Crinkle
- J. Bonded Charcoal + Current
- K. Bonded Charcoal + Loft
- L. Bonded Charcoal + Tilt





# BONDED QUARTZ APPLICATIONS



**Left:** LEVELe-103 Elevator Interior: Bonded White, Kalahari pattern; and Stainless Steel, Seastone finish. Aloft Bengaluru Cessna Business Park, Bangalore, Karnataka, India.

**Top Middle:** LEVELe-104 Elevator Interior with customized panel layout: Bonded Charcoal, Grass pattern; and ViviChrome Chromis glass, White interlayer, Standard finish. 1635 Market Street, Philadelphia, Pennsylvania.

**Top Right:** LEVELe Wall Cladding System with Bonded White, Crinkle pattern. MoZaic, Minneapolis, Minnesota.

**Right:** Wall panels in Bonded Charcoal, Loft pattern. Spiceworks, Hutto, Texas.

**Opposite Page:** Wall panels in Bonded White, Crinkle pattern. Corporatedge Office - IAAD, Gurgaon, Haryana, India.













# SYSTEMS

LEVELe Wall Cladding System

LightPlane Panels

Elevator Interiors + Doors

Columns + Column Covers











# LEVELe WALL CLADDING SYSTEM

The LEVELe program unites remarkable design flexibility, green materials, and the convenience of a panelized system.

The highly configurable LEVELe Wall Cladding System is designed to accommodate a wide range of field conditions without sacrificing ease of specification, installation, maintenance, or breadth of material choices.

Aluminum-framed panels with a lightweight structural backing form the basis of the system. Panel frames incorporate LEVELe's wall panel attachment system; panel insets draw from our full Surfaces line-up. Four panel styles provide different visual end results and support different material selections.

Standard system components—corners, bases, and self-revealing mounting channels—eliminate the need for custom solutions and make it easy to resolve typical trim and installation challenges.

The LEVELe Wall Cladding System coordinates with LEVELe Elevator Interiors, LEVELe Columns, and LightPlane Panels.

For more details, visit [www.forms-surfaces.com/levele-wall-cladding-system](http://www.forms-surfaces.com/levele-wall-cladding-system)

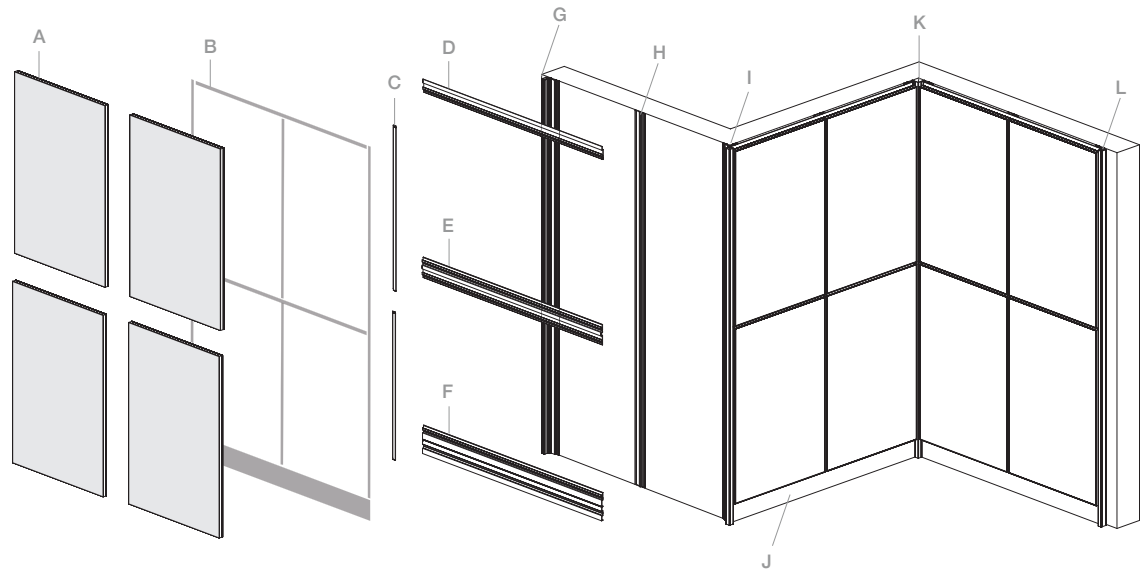

LEVELe Wall Cladding System Components

- |                                |                             |
|--------------------------------|-----------------------------|
| A. Wall Panel                  | G. End Stop Extrusion       |
| B. Reveal Tape                 | H. Hat Channel Extrusion    |
| C. Hat Channel Cover           | I. Outside Corner Extrusion |
| D. Top Cleat Extrusion         | J. Base                     |
| E. Wall Reveal Cleat Extrusion | K. Inside Corner Extrusion  |
| F. Base Cleat Extrusion        | L. End Stop Extrusion       |



# LIGHTPLANE PANELS

LightPlane Panels are engineered edge-lit LED panels that allow seamless illumination of walls, columns, elevator interiors and standalone panels and displays.

LightPlane Panels combine our cutting-edge lighting technology, VividGlass laminated glass or BermanGlass Levels kiln cast glass, and a highly engineered framing system to create an illuminated panel unlike any other.

With a remarkably thin profile and a minimal bezel, LightPlane Panels provide uniform light output, energy efficiency, and the unparalleled performance of Cree® LEDs. Each LightPlane Panel is manufactured with a size-specific algorithm to ensure the look of even, natural light, and eliminate hot spots, haloes or dark areas.

LightPlane Panels represent a complete system that can be easily configured to meet individual project needs. LightPlane Panels readily integrate with our LEVELe Wall Cladding and Column Systems and LEVELe Elevator Interiors.

For more details, visit [www.forms-surfaces.com/lightplane-panels](http://www.forms-surfaces.com/lightplane-panels)

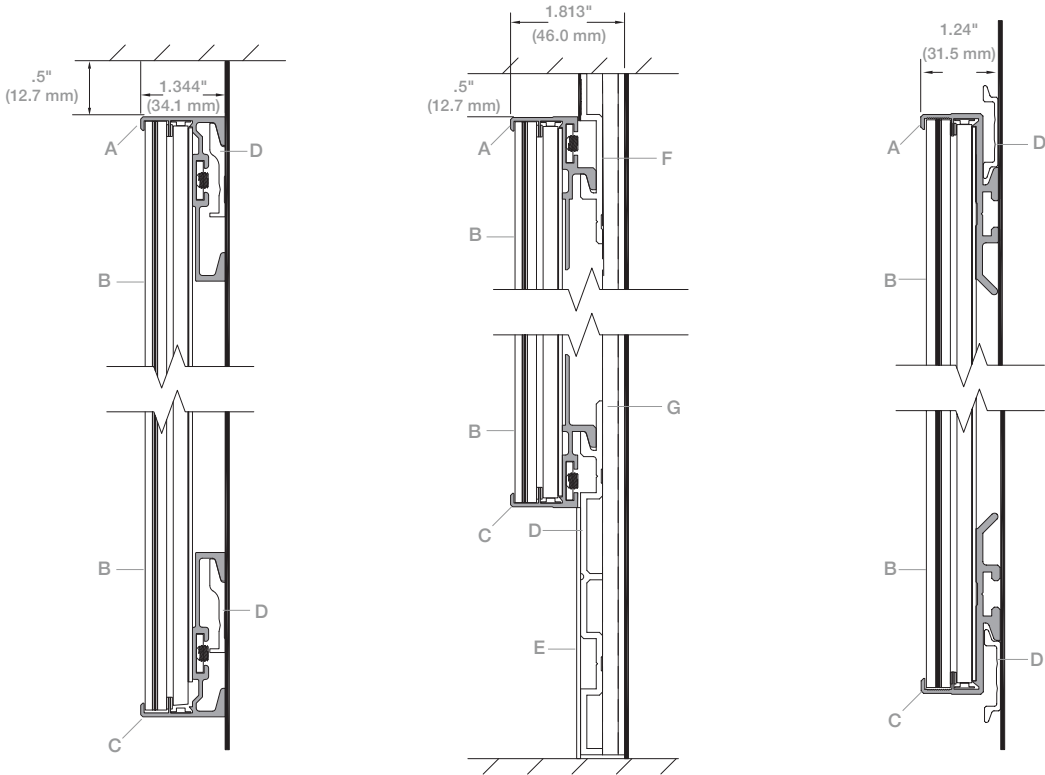

### Standalone Panel Components

- A. LightPlane Panel Top Extrusion
- B. Glass
- C. LightPlane Panel Bottom Extrusion
- D. Mounting Extrusion

### LEVELe Wall & Column Panel Components

- A. LightPlane Panel Top Extrusion
- B. Glass
- C. LightPlane Panel Bottom Extrusion
- D. Base Cleat
- E. Base Facing
- F. Top Cleat Extrusion
- G. Hat Channel Extrusion

### LEVELe Elevator Interior Panel Components

- A. LightPlane Panel Top Extrusion
- B. Glass
- C. LightPlane Panel Bottom Extrusion
- D. Panel Clip



# ELEVATOR INTERIORS + DOORS

F+S Elevator Interiors and Doors meet the needs of new or modernization projects everywhere.

Since introducing our comprehensive program more than twenty years ago, we've become expert in the requirements of elevator interiors. Panel and ceiling weights, energy efficiency, air quality, and lighting all have increasing importance in today's buildings.

LEVELe Elevator Interiors were developed to address these issues and meet diverse aesthetic, performance, environmental, and budgetary requirements. Complete packages draw on our full Surfaces line-up and suit all typical cab sizes and door configurations. LEVELc Elevator Interiors add to the range of possibilities.

Elevator Doors round out the program. Included within this group are door skins for elevator car doors and hoistway doors in Stainless Steel, Fused Metal and Bonded Metal.

LEVELe Elevator Interiors coordinate with our LEVELe Wall Cladding and Column Systems, and LightPlane Panels.

For more details, visit [www.forms-surfaces.com/elevator-interiors](http://www.forms-surfaces.com/elevator-interiors) and [www.forms-surfaces.com/elevator-doors](http://www.forms-surfaces.com/elevator-doors)

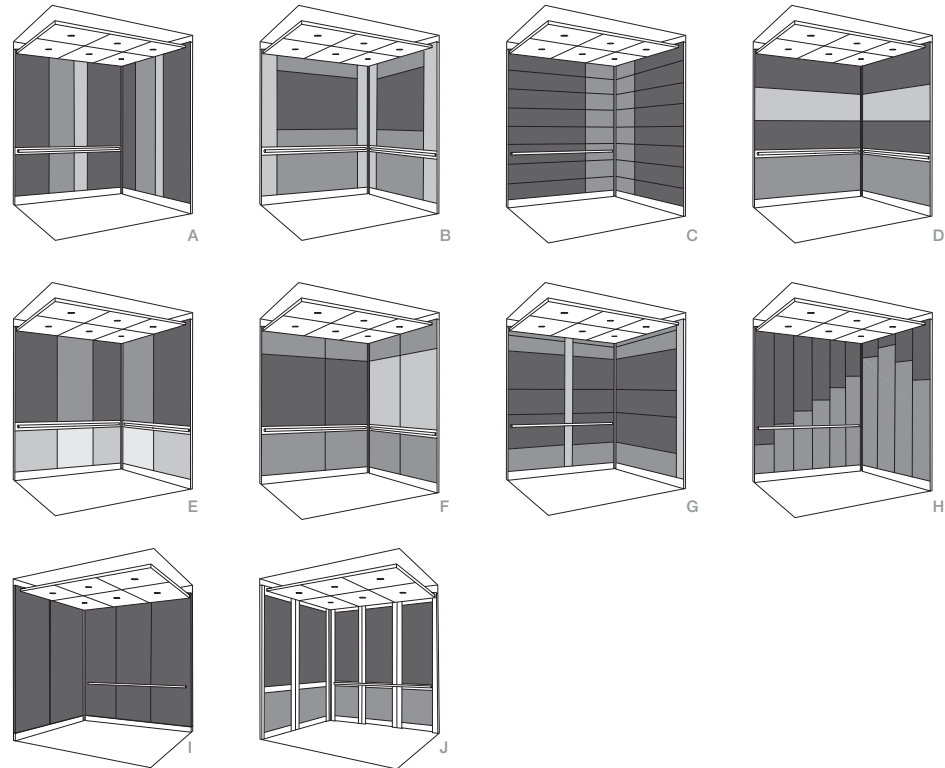

## LEVELe Elevator Interior Configurations

- |               |               |
|---------------|---------------|
| A. LEVELe-101 | E. LEVELe-105 |
| B. LEVELe-102 | F. LEVELe-106 |
| C. LEVELe-103 | G. LEVELe-107 |
| D. LEVELe-104 | H. LEVELe-108 |

## LEVELc Elevator Interior Configurations

- |                 |
|-----------------|
| I. LEVELc-1000A |
| J. LEVELc-2000N |



# COLUMNS + COLUMN COVERS

The LEVELe Column System aligns with the LEVELe family and, like the rest of the group, is based on a series of individual panels comprised of two configurable elements: frames and insets. The extruded aluminum frames serve as the framing elements for the insets and incorporate LEVELe's innovative column panel attachment system. Inset options draw from our Surfaces line-up and include LightPlane Panels.

The LEVELe Column System is appropriate for square and rectangular column shapes.

F+S Column Covers are engineered to accommodate real-world field conditions while offering impressive design flexibility.

Column Covers in stainless steel and Fused Metal are a durable, versatile solution for cladding existing structural columns. Designed to suit a wide range of field conditions, they can be adapted for site-specific needs and used for round, square or irregularly shaped columns.

For more details, visit [www.forms-surfaces.com/columns](http://www.forms-surfaces.com/columns)

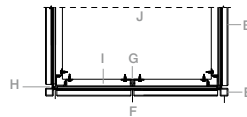
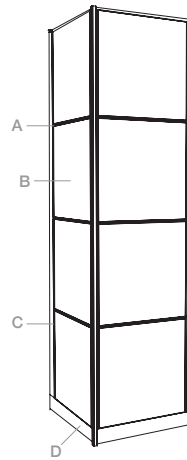

**LEVELe Column System Components**

- A. Reveal
- B. Panel Inset
- C. Panel Frame
- D. Base
- E. Outside Corner Extrusion
- F. Vertical Reveal Strip
- G. Hat Channel Extrusion
- H. Corner Reveal
- I. Wall Reveal Cleat Extrusion
- J. Existing Column

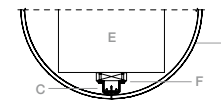
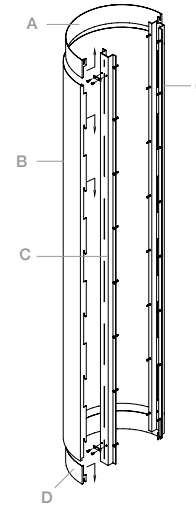

**Round Column Cover Components**

- A. Top Trim
- B. Facing Material
- C. Mounting Channel
- D. Bottom Trim
- E. Existing Column
- F. Blocking

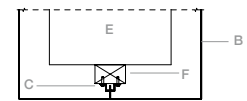
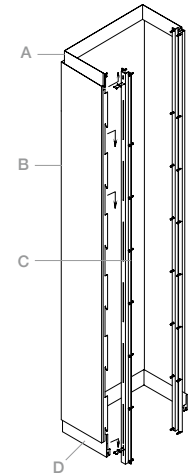

**Square Column Cover Components**

- A. Top Trim
- B. Facing Material
- C. Mounting Channel
- D. Bottom Trim
- E. Existing Column
- F. Blocking





VEKTR DIGITAL CANVAS™

A FORMS+SURFACES DESIGN TOOL



TRY IT NOW!



Drop Image Here  
Click to browse your files

REGISTER TODAY FOR MORE FEATURES!

Create a free account to save your VEKTR designs, and bring customized interpretations of your own digital imagery to architectural glass projects.

REGISTER

Already registered?



Don't show this again.

© 2017 Forms+Surfaces



# DESIGN TOOLS

VEKTR Digital Canvas  
Zoom Digital Darkroom  
Virtual Quarry  
Elevator Design Studio











# VEKTR DIGITAL CANVAS

---

The VEKTR Digital Canvas (VDC) gives you the freedom to transform digital images of any size, from any source, into highly customized ViviSpectra VEKTR glass designs—all in a matter of minutes. Simply capture the shot you want, drag it into the app, and start designing.

Technically speaking, the VDC converts raster images of any size into infinitely scalable, highly customizable vector artwork—referenced in the VDC as a 'canvas'. Each canvas generates a unique multilayered file that's output as the interlayers in our ViviSpectra VEKTR glass.

Within the VDC, canvas patterns, colors and dimensions are fully customizable. You can experiment with filters, colors and abstraction levels, visualize canvases in 2D and 3D, view your progress in live renderings, download and save your work, create projects, request budget pricing, and go from start to finish without leaving the app.

The VDC gives you endless ways to bring your imagination to glass.

Capture the potential at [www.vektrdigitalcanvas.com](http://www.vektrdigitalcanvas.com)





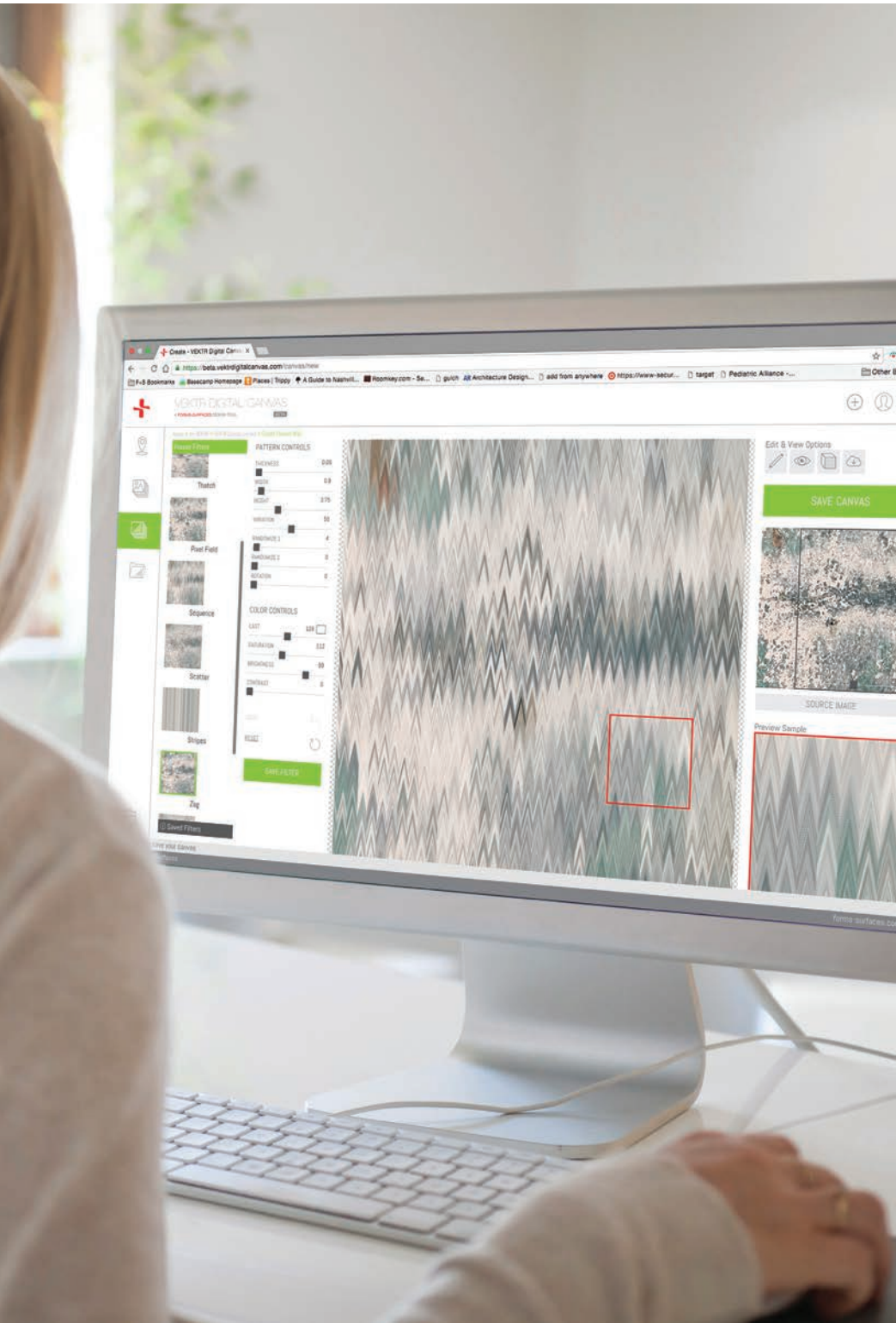



# ZOOM DIGITAL DARKROOM

---

The Zoom Digital Darkroom (ZDD) makes it easier than ever to bring the stunning photographic beauty of the world around us to large-scale glass applications and transform public spaces with ViviSpectra Zoom glass.

Part interactive design studio, part curated photo library, the Zoom Digital Darkroom gives you access to Zoom images—our growing collection of large-scale, super-high-resolution photos created using sophisticated gigapixel image capturing equipment.

It also gives you the tools you need to get creative with these photos. Using the ZDD you can browse, sort and select Zoom images, size, scale and crop your selections, zoom in and out to customize your designs, manage your projects, and request budget pricing—all from within the app.

As comprehensive as it is intuitive, Zoom essentially puts you behind the lens to develop your own unique point of view.

Zoom in today: [www.zoomdigitaldarkroom.com](http://www.zoomdigitaldarkroom.com)

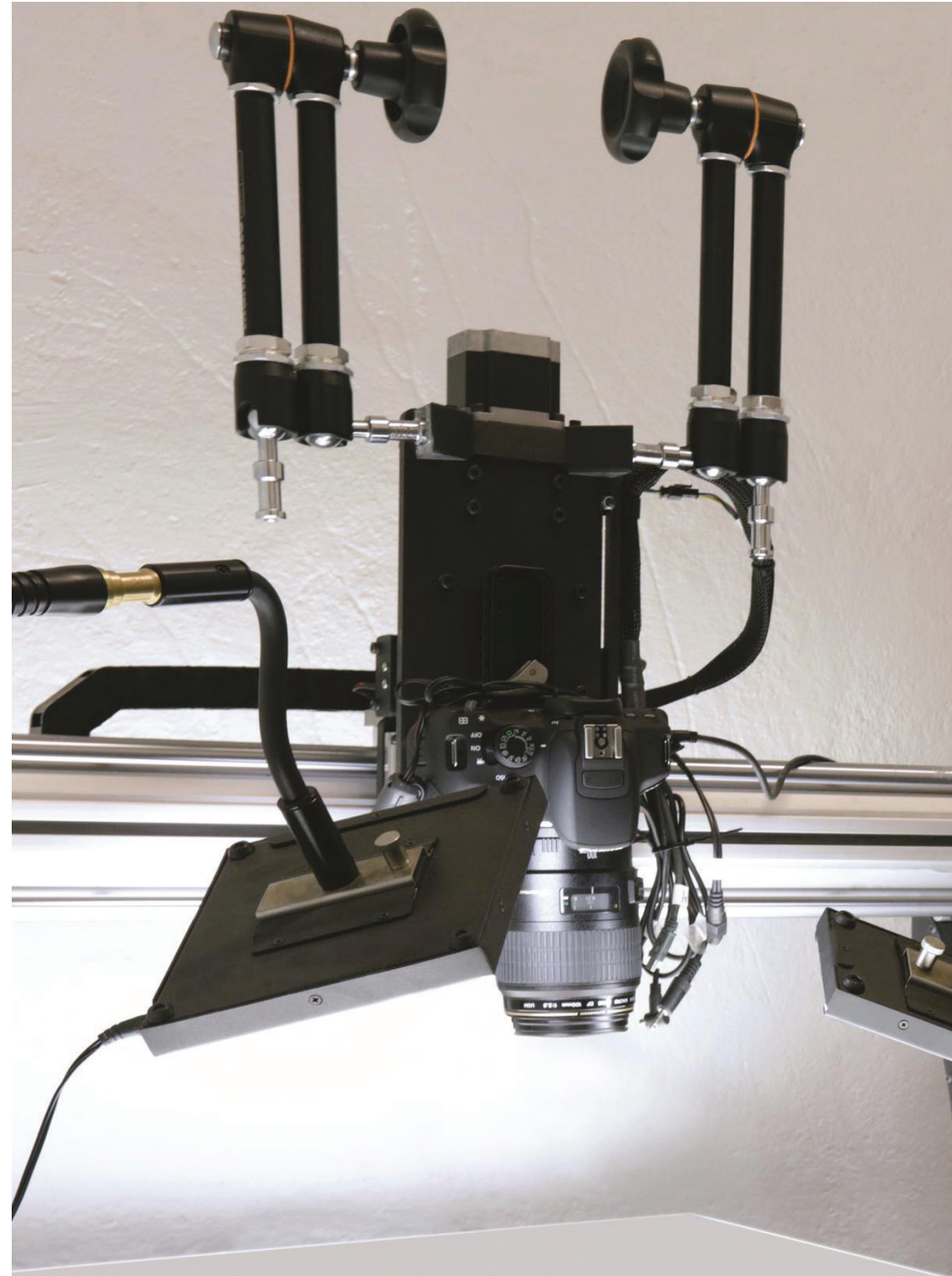







# VIRTUAL QUARRY

---

The Virtual Quarry (VQ) allows you to unleash your creativity, free from the physical constraints of real stone, and transform projects of any size with ViviStone glass.

The Virtual Quarry houses each of our ViviStone slab libraries so you can quickly see and compare your options all in a single location.

It also includes a full suite of tools for configuring your ViviStone designs. From within the VQ you can select your slabs, explore ideas, shape and assemble your layouts, work on multiple projects simultaneously, share ideas with clients or colleagues, manage your projects, and request budget pricing, all without leaving the app.

The Virtual Quarry is intuitive, informative and fun—and a great way to bring your ViviStone projects to life.

Try it for yourself at [www.virtualquarry.com](http://www.virtualquarry.com)









# ELEVATOR DESIGN STUDIO

The Elevator Design Studio (EDS) is a time-saving, interactive tool that puts creative control at your fingertips. The intuitive step-by-step format lets you choose an elevator interior configuration, apply materials and finishes from our extensive Surfaces palette, build your designs, view your progress in realistic renderings, and request budget pricing – all with a few simple clicks.

Within a project you can add multiple elevator interiors, work through design ideas, note job-related details, and save Surfaces to your 'Favorites' library for future reference and use.

Unparalleled in its reach, the Elevator Design Studio is a comprehensive visualization tool that lets you tailor our Surfaces and Elevator Interiors to your project-specific needs.

Get started at [www.elevatordesignstudio.com](http://www.elevatordesignstudio.com)









# COMPREHENSIVE SUPPORT

---

## Systems that Invite Creativity

---

All of our Systems products balance the convenience of a standardized system with impressive design flexibility. Our Systems let you move seamlessly from bold new concept to installed reality by:

- Providing a framework for our Surfaces: with literally hundreds of material and finish combinations to choose from, you benefit from countless design options as well as the cost-efficiencies of using our Surfaces in our Systems, and vice versa.
- Addressing mechanical details: those you see, like trim pieces and other finishing elements, and those you don't, like attachment systems and mounting assemblies. This gives you the freedom to focus on designs and finishes, while saving on the time and costs associated with custom solutions.
- Offering project-specific technical support that can help you with:
  - Shop drawings and project detailing
  - Material yields
  - Weight calculations
  - Mounting and installation details
  - Budget pricing early in the process

## Interrelated Product Lines

---

Our interrelated product lines make it easy to carry design and material themes across a property.

Within our line you'll find:

**Surfaces** – as introduced on the preceding pages, an extensive palette of materials, finishes and patterns that can be specified as sheet goods or incorporated into many F+S products.

**Systems** – the products represented throughout this book: walls, LightPlane Panels, elevator interiors, elevator doors, columns, and doors.

**Site Furniture** – a versatile group that includes benches, bike racks, litter & recycling receptacles, planters, tables and chairs.

**Outdoor Lighting** – contemporary designs, precision craftsmanship, and LED technology shape our collection of bollards and pedestrian fixtures.

## Time-Tested Expertise

---

We recognize that every project is unique, and that multi-faceted projects require an array of talents and capabilities.

For nearly five decades, we've worked with our clients to develop real-world product solutions.

We've also invested steadily in high-end manufacturing facilities and equipment, innovative materials and finishes, and the skilled professionals that make up our team.

So, whether you're navigating building code requirements, ADA guidelines or environmental issues, we're here to support you at every step in the process by giving you access to:

- Unparalleled manufacturing expertise
- State-of-the-art technologies and materials
- Decades of industry experience
- Products with proven performance in demanding environments
- Knowledgeable employees around the world who can assist you with design and engineering challenges, project management, sustainability compliance, and technical and customer support



# ADDITIONAL RESOURCES

---

## Visit Our Website: [www.forms-surfaces.com](http://www.forms-surfaces.com)

Updated regularly, our website is a comprehensive resource designed to help you discover what's new and stay up-to-date on product and company developments. In support of all of our Systems and Surfaces, you'll find:

- + Product Data Sheets & Design Guides
- + Full-sheet Pattern Drawings
- + Technical Specs
- + Installation Instructions
- + Environmental Data
- + Image Galleries
- + Project References

## Contact Us

Contact Forms+Surfaces for additional information about any of our products or to reach a sales representative in a territory near you.

- + Telephone: 800.451.0410
- + General Inquiries:  
[marketing@forms-surfaces.com](mailto:marketing@forms-surfaces.com)
- + Sustainability: [green@forms-surfaces.com](mailto:green@forms-surfaces.com)

## US LOCATIONS

### Pennsylvania

30 Pine Street  
Pittsburgh, PA 15223  
P 800.451.0410  
P 412.781.9003  
F 412.781.7840

### California

5055 6th Street  
Carpinteria, CA 93013  
P 800.451.0410  
F 805.684.8620

### Arizona

1025 North 71st Avenue  
Phoenix, AZ 85043  
P 800.451.0410  
F 623.594.6312

## INTERNATIONAL LOCATIONS

### UK / Europe

88 Kingsway  
London WC2B 6AA  
P +44 203 755 3731  
F +44 207 841 1001

### Middle East

Suite B 307, Dubai, Silicon Oasis  
PO Box 341052, Dubai, UAE  
P +971 4 501 5605  
F +971 4 501 5606

### Middle East

Level 2, Louis Vuitton Building  
Suite 2029, Allenby Street  
Beirut, Lebanon  
+961 1 957540

### India

Office No. 104, Pentagon 4,  
Magarpatta City, Hadapsar,  
Pune 411028, MH, India  
P +91 20 67482400

### Hong Kong

11/F, AXA Centre,  
151 Gloucester Road,  
Wanchai, Hong Kong  
P +852 25823742  
F +852 30113864

### Singapore

60 Kaki Bukit Place,  
#02-10, Eunos Tech Park  
Singapore 415979  
P +65 6748 8383  
F +65 6441 1185

### Thailand

37th Floor,  
Sathorn Square Office Tower  
98 North Sathorn Road Silom,  
Bangrak, Bangkok 10500 Thailand  
P +66 2 105 6447  
F +66 2 105 6301

### Taiwan

No. 18, Ln. 238, Gongye Road  
Longjing District,  
Taichung City 434,  
Taiwan (R.O.C.)

*Sign up for Forms+Surfaces  
New Product Announcements at  
[www.forms-surfaces.com/news](http://www.forms-surfaces.com/news)*



# FORMS+SURFACES®



We maintain an Environmental Management System and are continually working to improve our impact through efficiency, material selection, vendor education, employee involvement, and an unwavering commitment to being exemplary corporate citizens. If you would like additional information on our Environmental Management System or our company environmental initiatives and policies, please feel free to contact our Sustainability Team at [green@forms-surfaces.com](mailto:green@forms-surfaces.com).

offices worldwide | 800.451.0410 | 412.781.9003 | [www.forms-surfaces.com](http://www.forms-surfaces.com)

Member of the USGBC | LEED® Accredited Professionals on Staff | FSC® Certified Supplier | FSC-C004453 | SCS-COC-001461 © 1996 Forest Stewardship Council A.C.

 Printed on 50% recycled, 25% post consumer paper

FSSURFBRO-0818-7500-REV005