

APEX™ BENCH

SURFACE MOUNT INSTALLATION INSTRUCTIONS FOR BENCHES WITH ADD-ON SECTIONS

MATERIALS INCLUDED

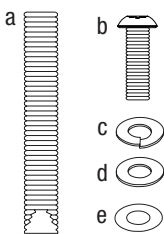
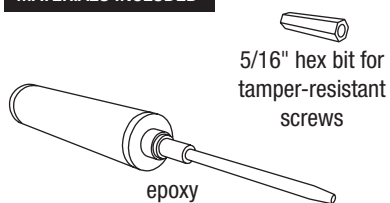

TOOLS NEEDED

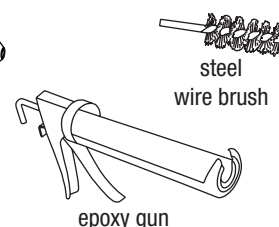
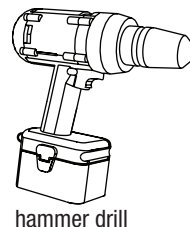
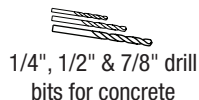
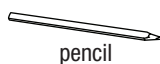

STEP BY STEP

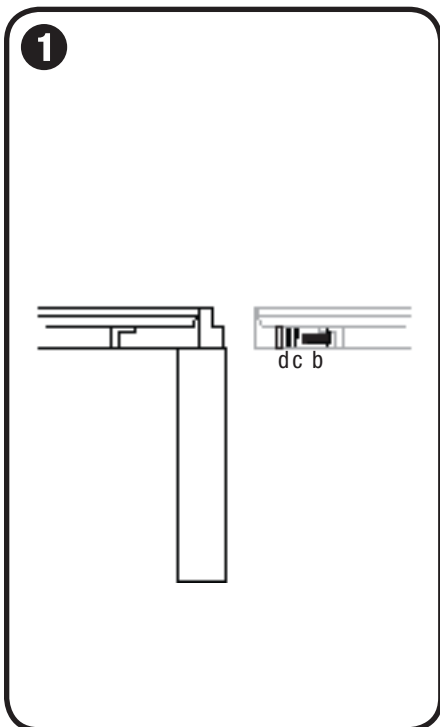

Connect add-on sections

- Position sections so end-to-end connection holes line up.
- Slide 1/2" stainless steel lock washer (c) and 1/2" stainless steel flat washer (d) onto each 1/2"-13 x 1-1/2" socket head cap screw (b).
- Thread into end-to-end connection holes in sections and tighten using provided 5/16" hex bit.

NOTE: Bench is not freestanding and must be supported during this step.

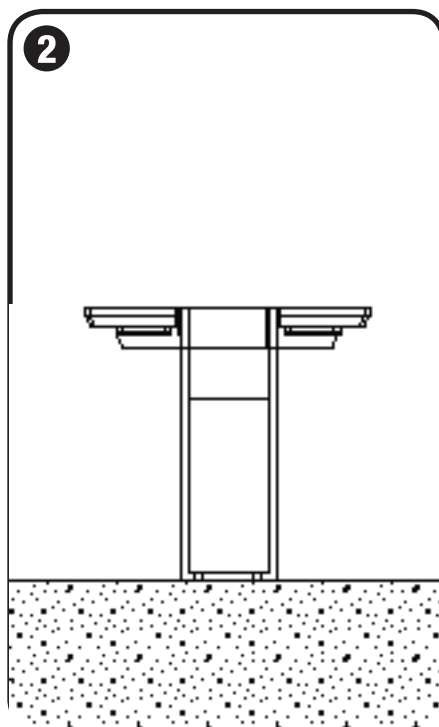

Mark hole locations

- Place bench in desired location. Mark center of each hole location with a pencil.

NOTE: Bench is not freestanding and must be supported during this step.

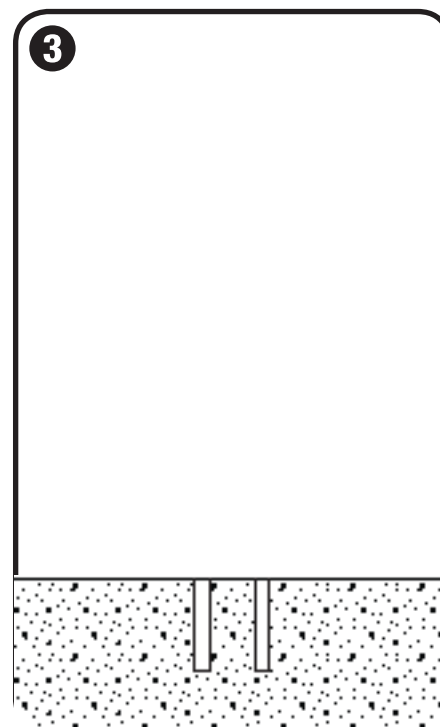

Drill holes

- Use hammer drill to drill 5" deep x 7/8" diameter anchor hole at each marked location using a 7/8" drill bit suitable for concrete drilling.

NOTE: Forms+Surfaces recommends starting holes with 1/4" diameter drill bit followed by 1/2" and finally 7/8" for maximum accuracy.

APEX™ BENCH

SURFACE MOUNT INSTALLATION INSTRUCTIONS FOR BENCHES WITH ADD-ON SECTIONS

STEP BY STEP

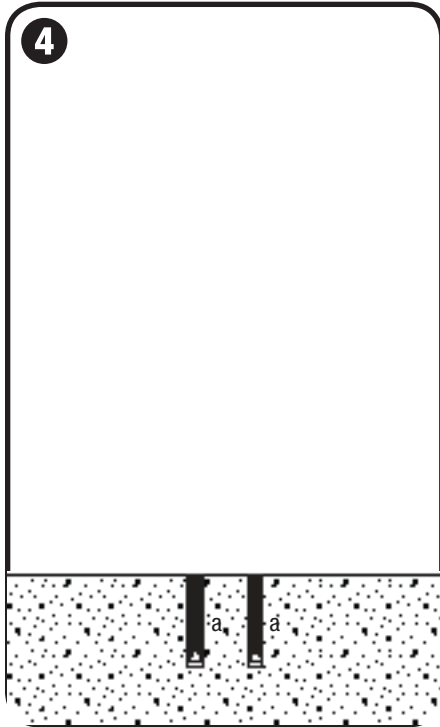

Fill holes & insert anchors

- Use compressed air and steel wire brush to clean each anchor hole in accordance with epoxy instructions.
- Use epoxy in epoxy gun to fill each anchor hole 5/8 of the hole depth in accordance with epoxy instructions.
- Insert 1/2"-13 x 5" epoxy anchor (a) into each anchor hole so anchor top is flush with ground. Allow proper curing time according to cure schedule on epoxy instructions before moving on to step 5.

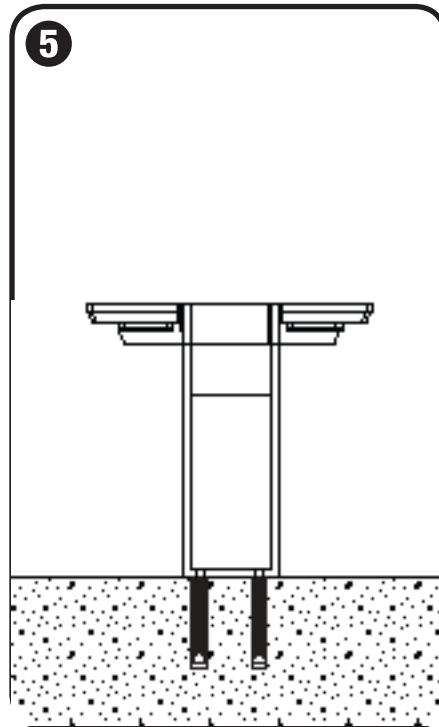

Position bench

- Position bench so that mounting holes line up with anchors.
- NOTE: Bench is not freestanding and must be supported until steps 5 and 6 are complete.

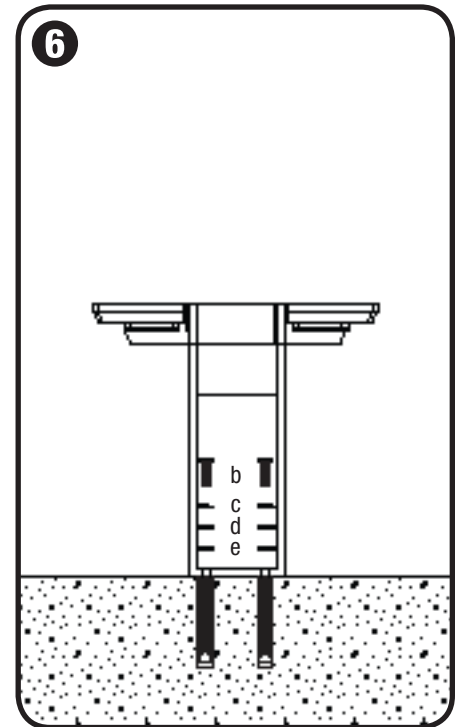

Attach bench

- Slide 1/2" stainless steel lock washer (c), 1/2" stainless steel flat washer (d), and 1/2" nylon flat washer (e) onto each 1/2"-13 x 1-1/2" tamper-resistant button head cap screw (b).
- Insert screws into mounting holes in bench and thread into anchors using provided 5/16" hex bit for tamper-resistant screws.
- Tighten screws until snug.