

# APEX™ TABLE ENSEMBLE

## SURFACE MOUNT INSTALLATION INSTRUCTIONS

### MATERIALS INCLUDED

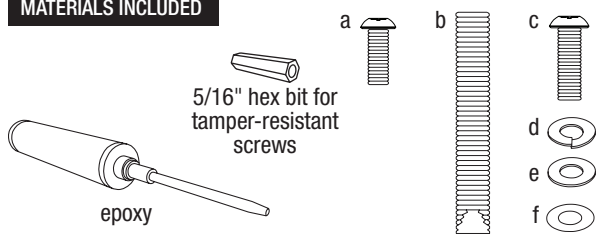

### TOOLS NEEDED

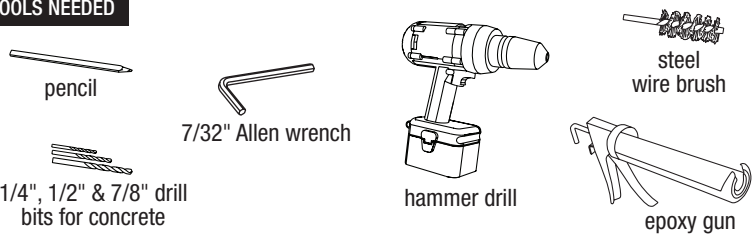

### STEP BY STEP FOR ALL APEX TABLE ENSEMBLES (TABLE & TWO BENCHES SHOWN)

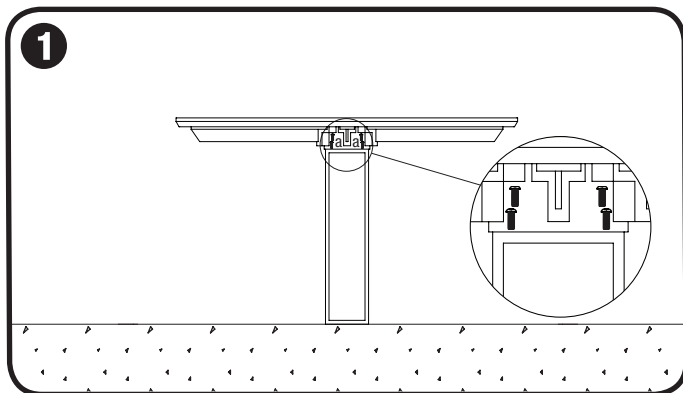

#### Attach table top to column

- Use 7/32" Allen wrench to attach table top to column using four (4) 3/8" -16 x 1" button head cap screws (a).

NOTE: Table top and column are not freestanding and must be supported during this step.

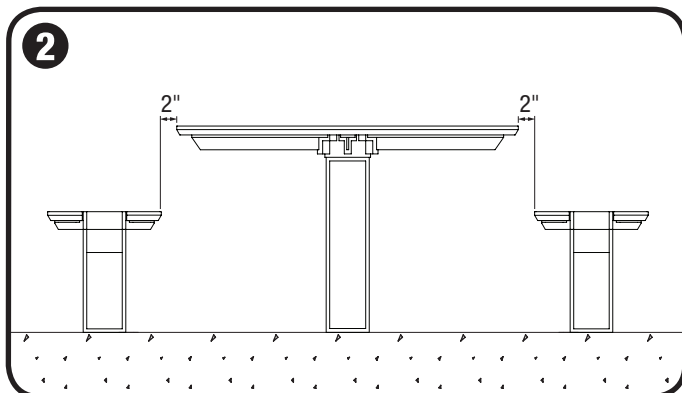

#### Mark hole locations

- Place benches and table in desired location. Mark center of each hole location with a pencil.
- The recommended gap between the bench edge and table edge is 2". Benches should be centered horizontally, 4" in from table sides.

NOTE: Table and benches are not freestanding and must be supported during this step.

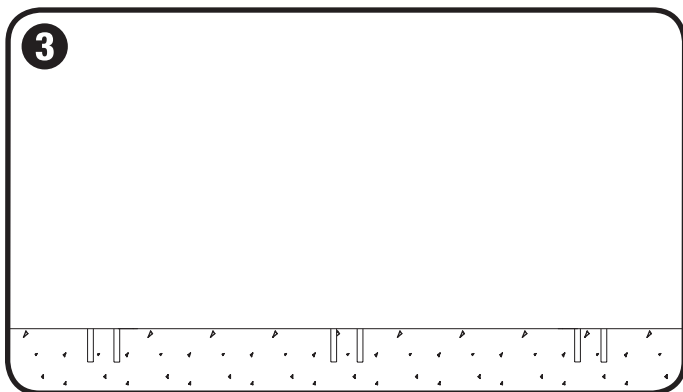

#### Drill holes

- Use hammer drill to drill 5" deep x 7/8" diameter anchor hole at each marked location using a 7/8" drill bit suitable for concrete drilling.

NOTE: Forms+Surfaces recommends starting holes with 1/4" diameter drill bit followed by 1/2" and finally 7/8" for maximum accuracy.

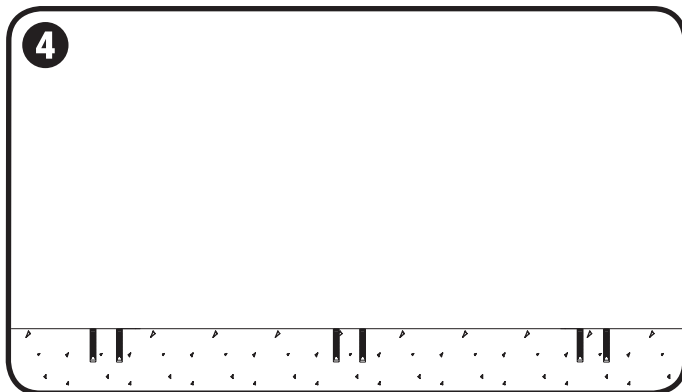

#### Fill holes & insert anchors

- Use compressed air and steel wire brush to clean each anchor hole in accordance with epoxy instructions.
- Use epoxy in epoxy gun to fill each anchor hole 5/8 of the hole depth in accordance with epoxy instructions.
- Insert 1/2"-13 x 5" epoxy anchor (a) into each anchor hole so top is flush with ground. Allow proper curing time according to epoxy cure schedule.

# APEX™ TABLE ENSEMBLE

## SURFACE MOUNT INSTALLATION INSTRUCTIONS

### STEP BY STEP FOR ALL APEX TABLE ENSEMBLES (TABLE & TWO BENCHES SHOWN)

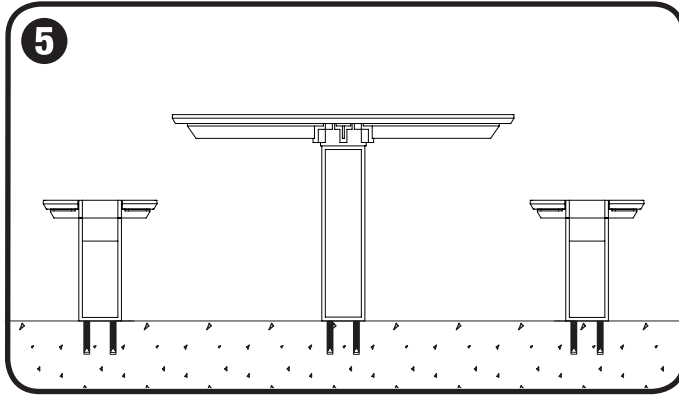

#### Position benches and table

- After recommended curing time, position benches and table over anchors so that mounting holes line up with anchors.

NOTE: Table and benches are not freestanding and must be supported during this step.

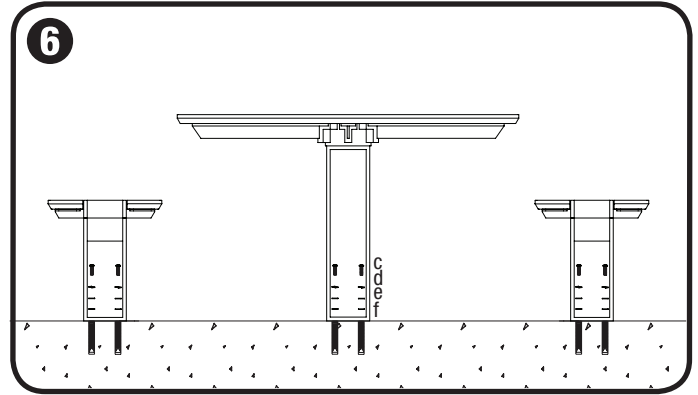

#### Attach benches and table

- Slide 1/2" stainless steel lock washer (d), 1/2" stainless steel flat washer (e), and 1/2" nylon flat washer (f) onto each 1/2"-13 x 1-1/2" tamper-resistant button head cap screw (c).
- Insert screws into mounting holes in table and benches and thread into anchors using provided 5/16" hex bit for tamper-resistant screws.

NOTE: Table and benches are not freestanding and must be supported during this step.

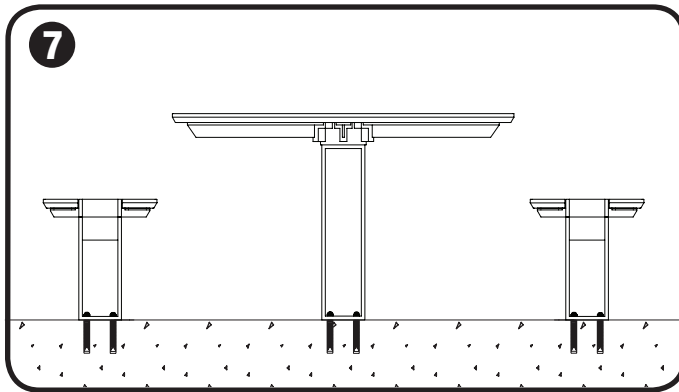

#### Tighten screws

- Tighten screws until snug.