

KNIGHT™ TABLE ENSEMBLE

SURFACE MOUNT INSTALLATION INSTRUCTIONS

MATERIALS INCLUDED



TOOLS NEEDED

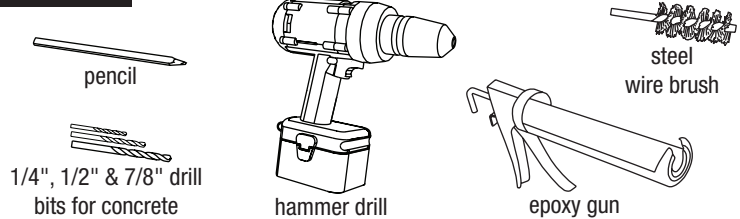

STEP BY STEP FOR ALL KNIGHT TABLE ENSEMBLES

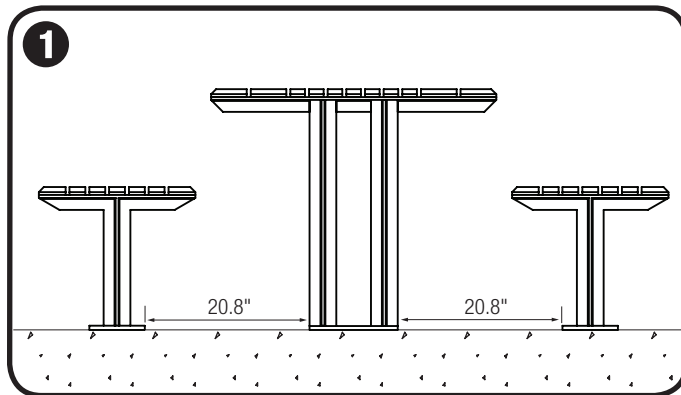

Mark hole locations

- Place benches and table in desired location. Mark center of each hole location with a pencil.
- The recommended distance between the bench bases and table base is 20.8".

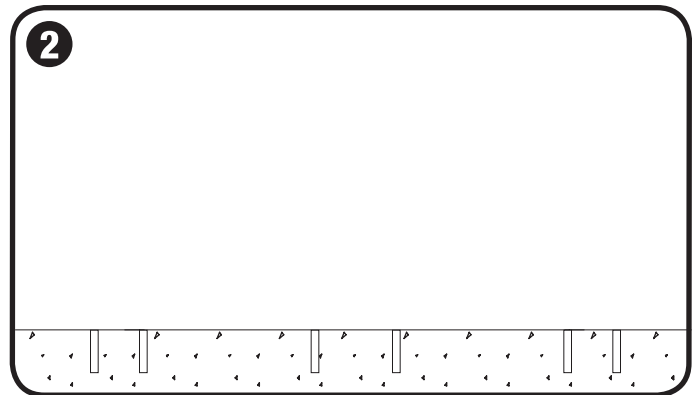

Drill holes

- Use hammer drill to drill 5" deep x 7/8" diameter anchor hole at each marked location using a 7/8" drill bit suitable for concrete drilling.
- NOTE: Forms+Surfaces recommends starting holes with 1/4" diameter drill bit followed by 1/2" and finally 7/8" for maximum accuracy.

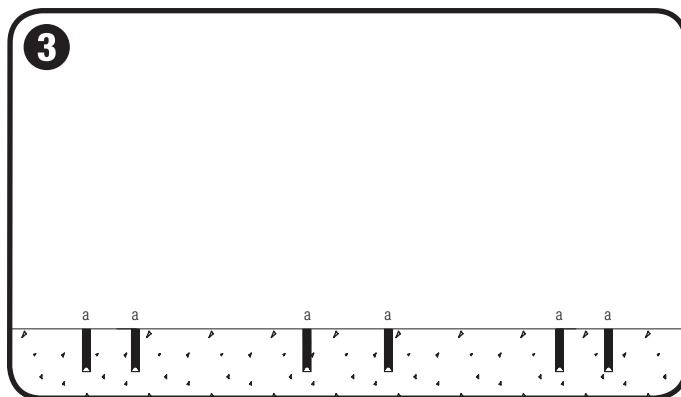

Fill holes & insert anchors

- Use compressed air and steel wire brush to clean each anchor hole in accordance with epoxy instructions.
- Use epoxy in epoxy gun to fill each anchor hole 5/8 of the hole depth in accordance with epoxy instructions.
- Insert 1/2"-13 x 5" epoxy anchor (a) into each anchor hole so top is flush with ground. Allow proper curing time according to epoxy cure schedule.

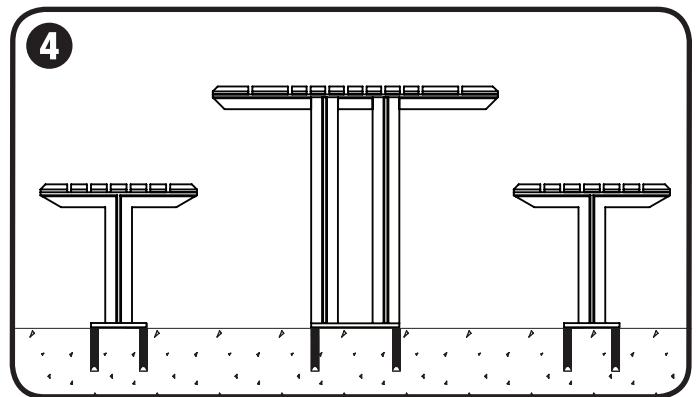

Position benches and table

- After recommended curing time, position benches and table over anchors so that mounting holes line up with anchors.

KNIGHT™ TABLE ENSEMBLE

SURFACE MOUNT INSTALLATION INSTRUCTIONS

STEP BY STEP FOR ALL KNIGHT TABLE ENSEMBLES

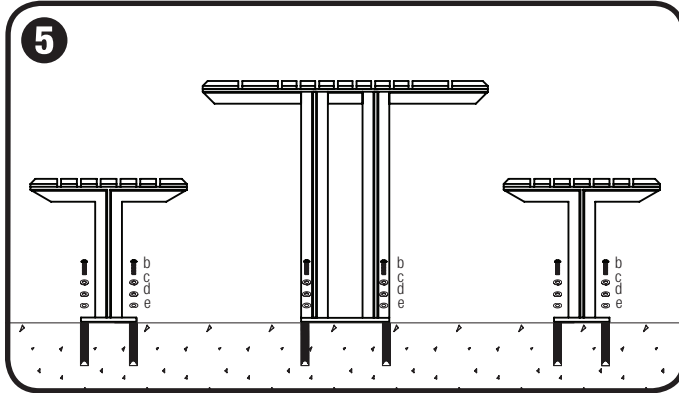

Attach benches and table

- Slide 1/2" stainless steel lock washer (c), 1/2" stainless steel flat washer (d), and 1/2" nylon flat washer (e) onto each 1/2"-13 x 1-1/2" tamper-resistant button head cap screw (b).
- Insert screws into mounting holes in table and benches and thread into anchors using provided 5/16" hex bit for tamper-resistant screws.

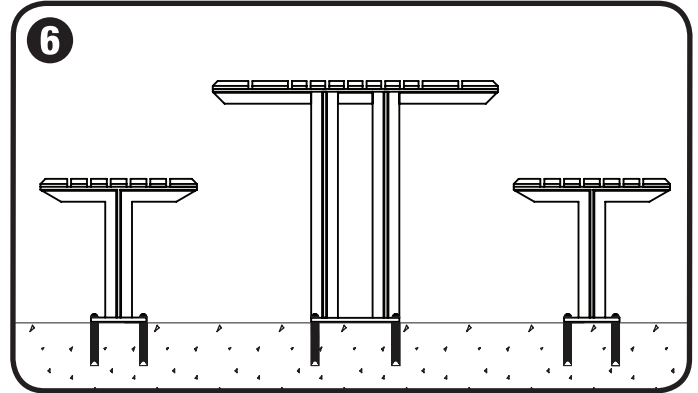

Tighten screws

- Tighten screws until snug.