

QUADRA SEATING SYSTEM

INSTALLATION INSTRUCTIONS

MATERIALS INCLUDED

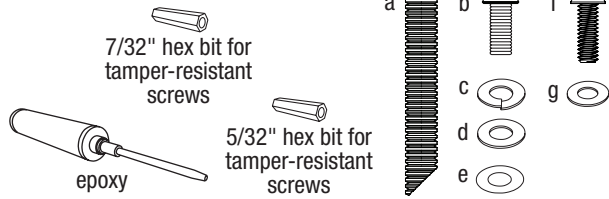

TOOLS NEEDED

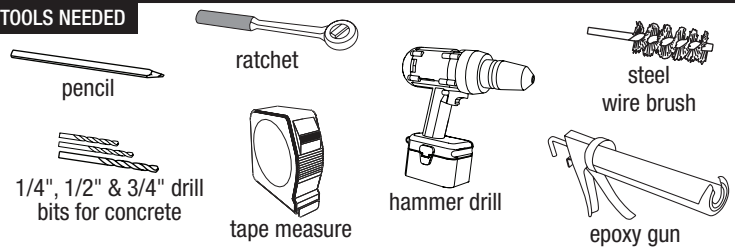

STEP BY STEP FOR ALL QUADRA SEATING SYSTEM MODULES (SBQUA-17A SHOWN)

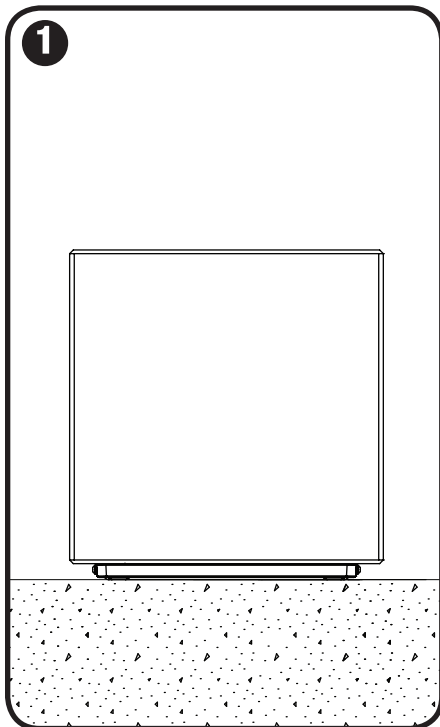

Position standalone seat

- Position seat in desired location. Be sure that the space allows enough room for full configuration.

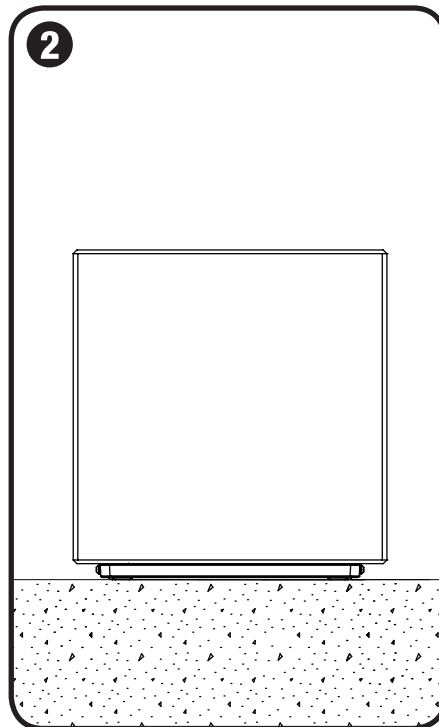

Adjust leveling feet

- Ensure that leveling feet are adjusted prior to surface mount installation.

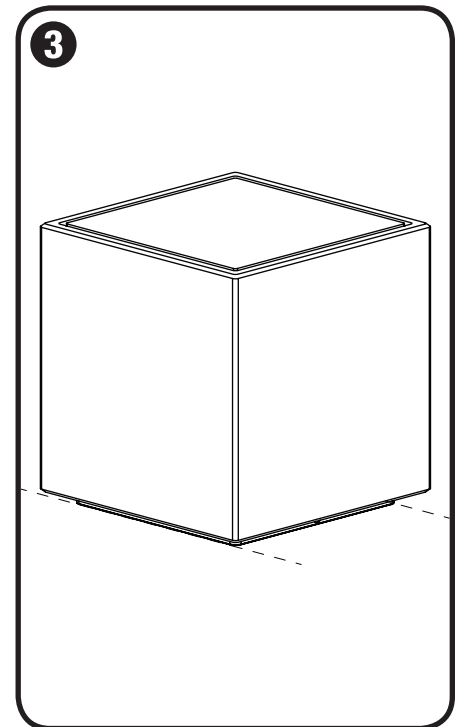

Mark surface mount location

- Once module is in the desired location, mark the ground along base plate on the non-notched sides.
- Carefully move seat to the side once mounting surface is marked.

QUADRA SEATING SYSTEM

INSTALLATION INSTRUCTIONS

STEP BY STEP FOR QUADRA SEATING SYSTEM CONFIGURATIONS WITH A STANDALONE SEAT

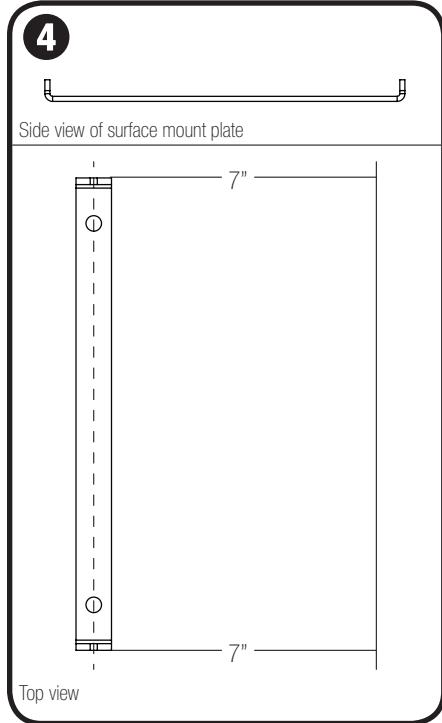

Position surface mount plate

- Measure and mark 7" from surface mount mark to find the surface mount plate center line, indicated by the dashed line.
- Position the surface mount plate by placing and centering surface mount plate on marked line.
- Next, align the mounting holes to the surface mount plate center line.
- Mark the center of each mounting hole.

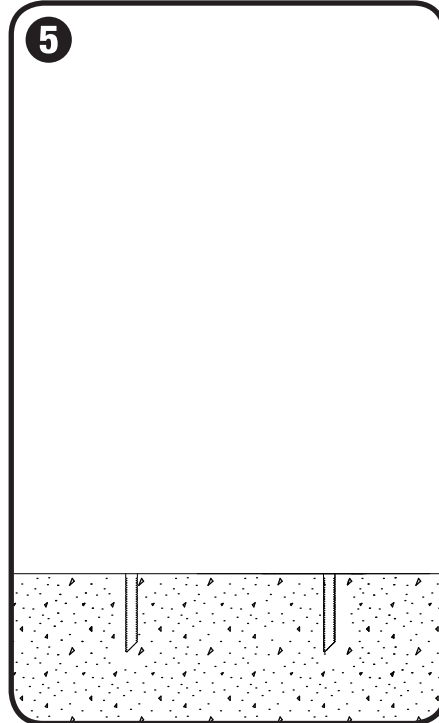

Drill holes

- Use hammer drill to drill 4.5" deep x 3/4" diameter anchor hole at each marked location using a 3/4" drill bit suitable for concrete drilling.

Note: Forms+Surfaces recommends starting holes with 1/4" diameter drill bit followed by 1/2" and finally 3/4" for maximum accuracy.

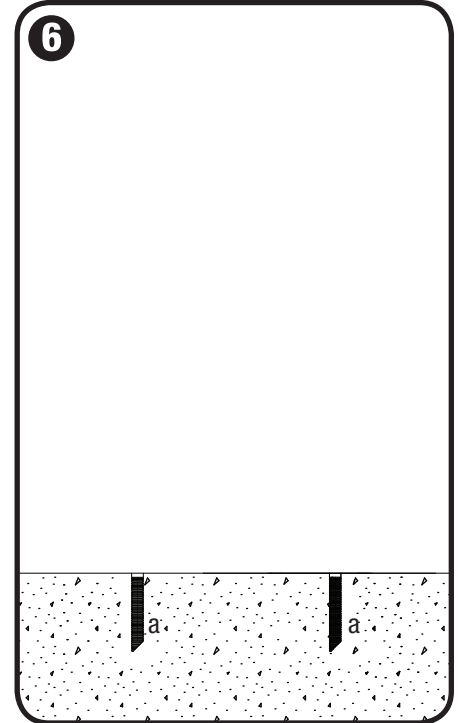

Fill holes & insert anchors

- Use compressed air and steel wire brush to clean each anchor hole in accordance with epoxy instructions.
- Use epoxy in epoxy gun to fill each anchor hole 5/8 of the hole depth in accordance with epoxy instructions.
- Insert 3/8"-16 x 4-1/4" epoxy anchor (a) into each anchor hole so anchor top is flush with ground. Allow proper curing time according to cure schedule on epoxy instructions before moving on to Step 8.

QUADRA SEATING SYSTEM

INSTALLATION INSTRUCTIONS

STEP BY STEP FOR QUADRA SEATING SYSTEM CONFIGURATIONS WITH A STANDALONE SEAT

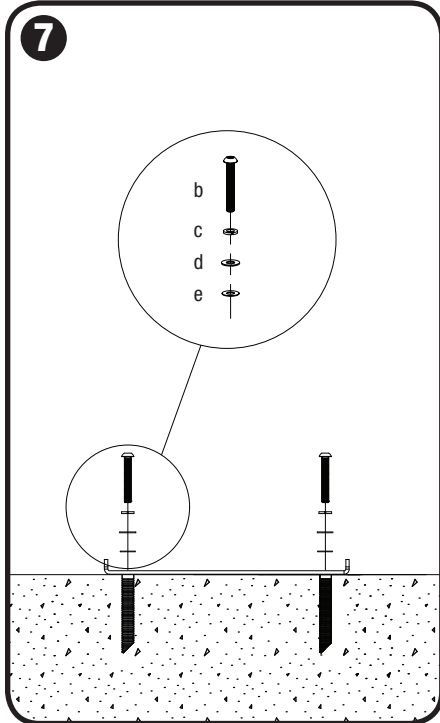

Attach surface mount plate

- Slide 3/8" stainless steel lock washer (c), 3/8" stainless steel flat washer (d), and 3/8" nylon flat washer (e) onto each 3/8"-16 x 2 1/2" tamper resistant button head cap screw (b).
- Insert screws into mounting holes in table base and thread into anchors using provided 7/32" hex bit for tamper-resistant screws.

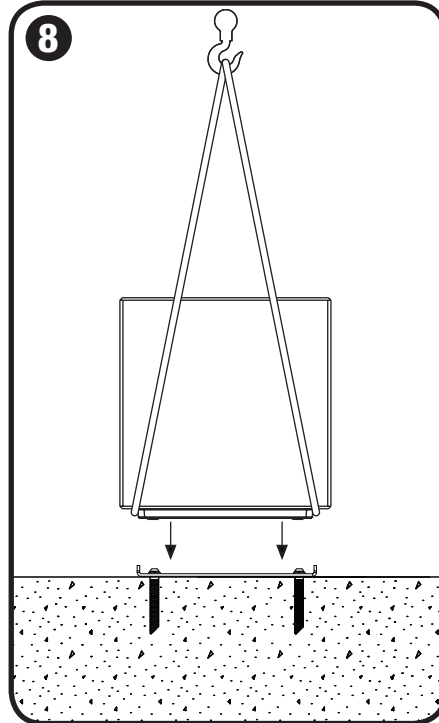

Fit module onto surface mount plate

- Lift module up and slide base plate onto mounted surface mount plate(s).

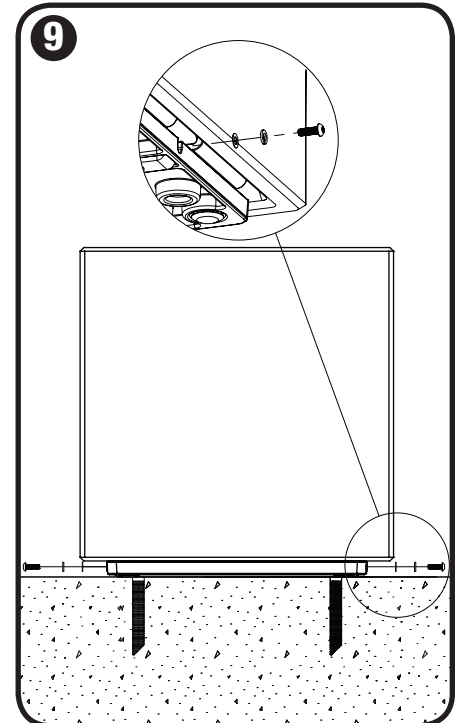

Attach base plate to surface mount plate

- Slide 1/4" flat washer (g) onto 1/4" - 20 tamper-resistant button head cap screw (f). Insert screw into base plate connection slots and surface mount plate tapped holes. Tighten using 5/32" hex bit for tamper resistant screws.