

TECNO RS SEATING SYSTEM

SURFACE MOUNT WITHOUT BASE PLATE INSTALLATION INSTRUCTIONS

MATERIALS INCLUDED				TOOLS NEEDED			

STEP BY STEP FOR SURFACE MOUNT CYLINDRICAL MOUNTING POST WITHOUT BASE PLATE.

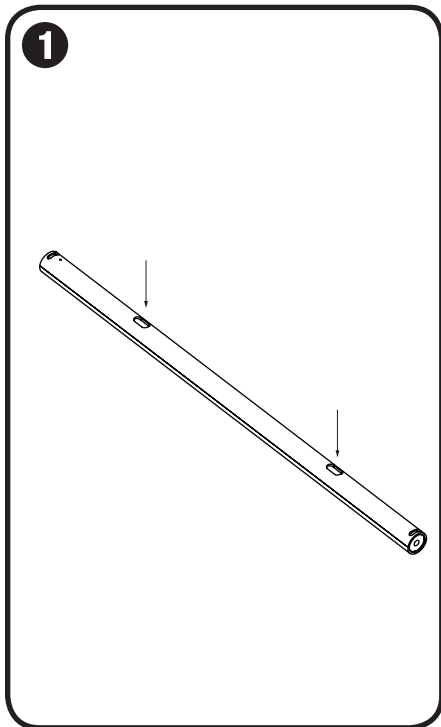

1 Mark hole locations

- Using the seat rail as a template, mark center of each hole location with a pencil.

Note: Ensure seat rail is properly protected when placing on the ground surface.

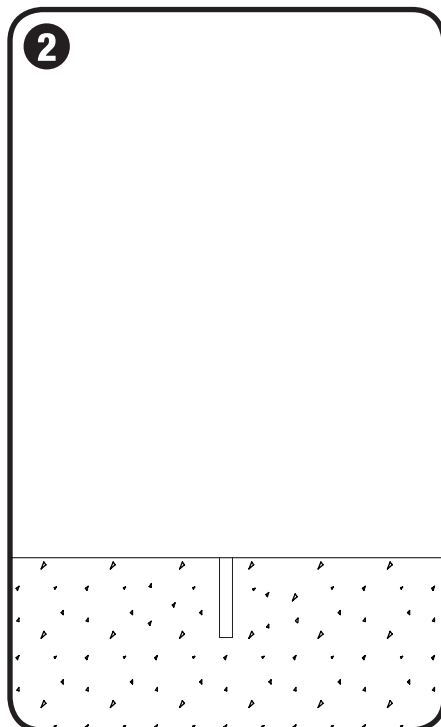

2 Drill holes

- Use hammer drill to drill 5" (125 mm) deep x 3/4" (18 mm) diameter anchor hole at each marked location using a 18mm drill bit suitable for concrete drilling.

NOTE: Forms+Surfaces recommends starting holes with 6mm diameter drill bit followed by 12mm and finally 18mm for maximum accuracy.

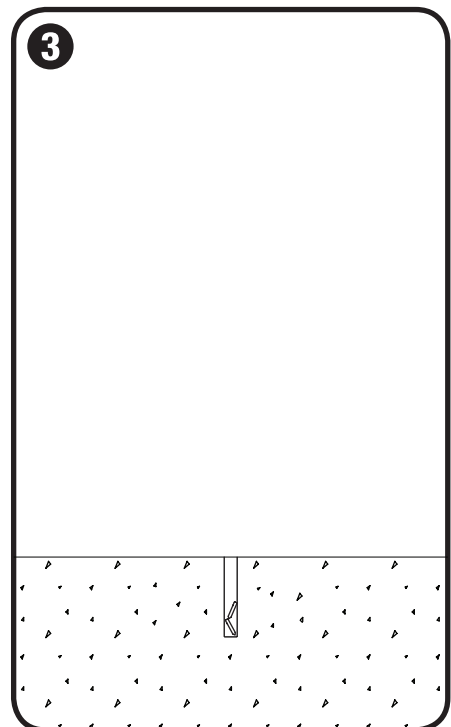

3 Prepare mounting holes

- Use compressed air and steel wire brush to clean each mounting hole.
- Drop two resin capsules (a) into each mounting hole.

TECNO RS SEATING SYSTEM

SURFACE MOUNT WITHOUT BASE PLATE INSTALLATION INSTRUCTIONS

STEP BY STEP FOR SURFACE MOUNT CYLINDRICAL MOUNTING POST WITHOUT BASE PLATE.

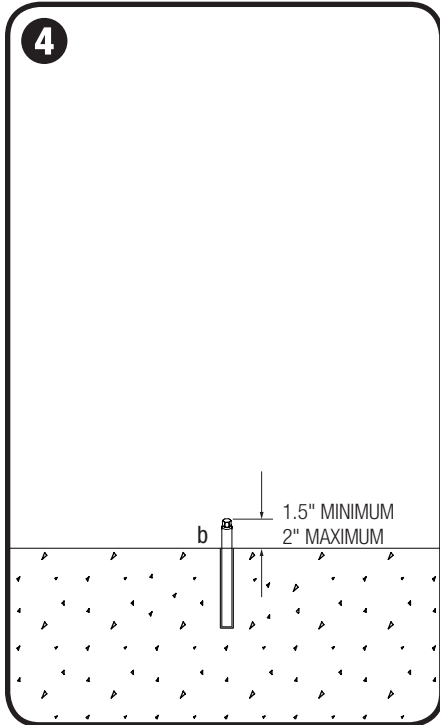

Break resin capsules

- Break capsules with threaded rod (b) and hammer drill using a M12 socket attachment.
- A minimum of 1.5" (38 mm) and maximum of 2" (51 mm) of the threaded rod should be above the ground surface.
- Allow a minimum of 20 minute curing time before moving on to Step 5.

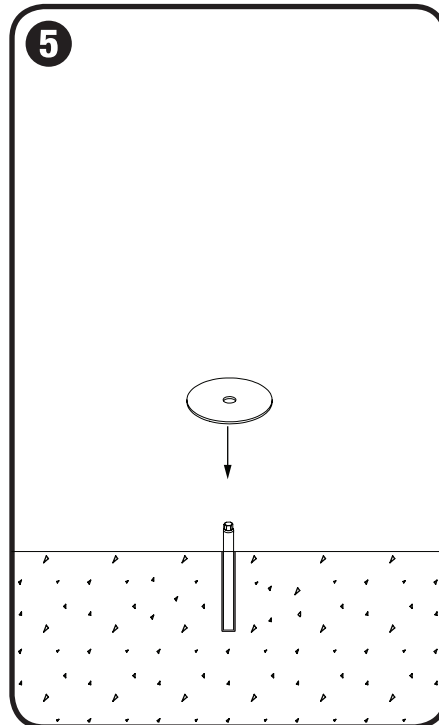

Attach surface mount plate cover

- Slide centering disk over threaded rod.

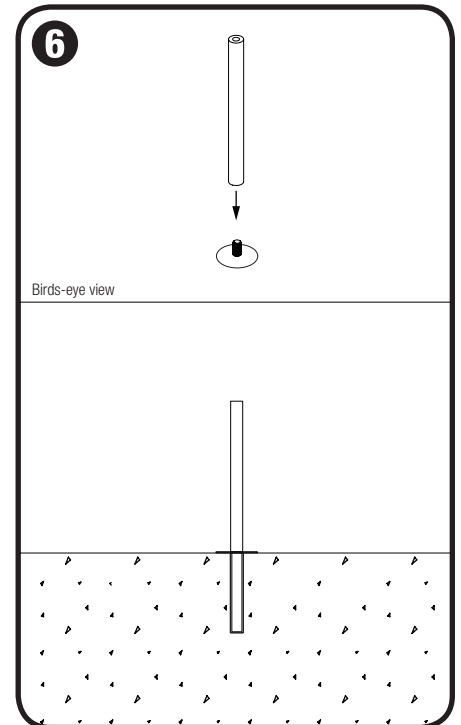

Attach mounting tie rod

- Screw mounting tie rod onto threaded rod.
- Tighten tie rod until snug against centering disk.

TECNO RS SEATING SYSTEM

SURFACE MOUNT WITHOUT BASE PLATE INSTALLATION INSTRUCTIONS

STEP BY STEP FOR SURFACE MOUNT CYLINDRICAL MOUNTING POST WITHOUT BASE PLATE.

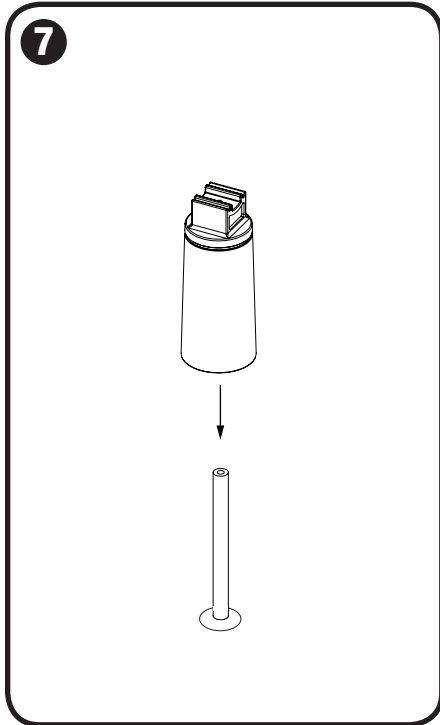

Attach mounting post

- Slide cylindrical mounting post over tie rod and centering disc.

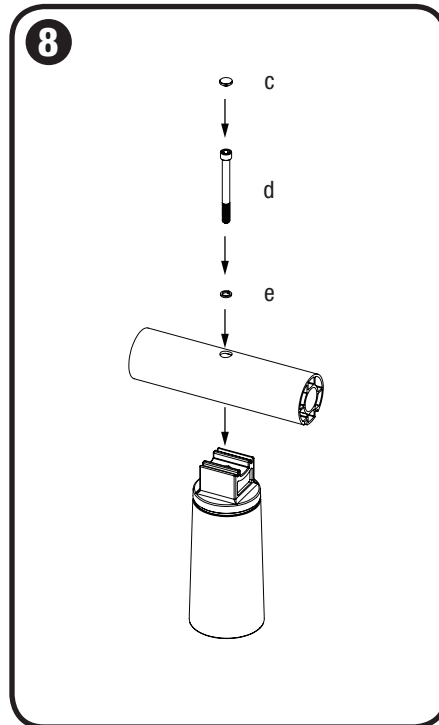

Attach seat rail to mounting post

- Once all mounting posts are secure, place seat rail onto rail mounting brackets. Ensure that connection holes in the seat rail and mounting brackets align.
- Insert M12 lock washer (e), then M12 x 120 socket head cap screw (d) into seat rail to secure seat rail to the rail mounting bracket.
- Tighten screw until snug.
NOTE: If screw is not tightened securely mounting posts will be loose.
- Fit nylon cap (c) onto the top of socket head cap screw.

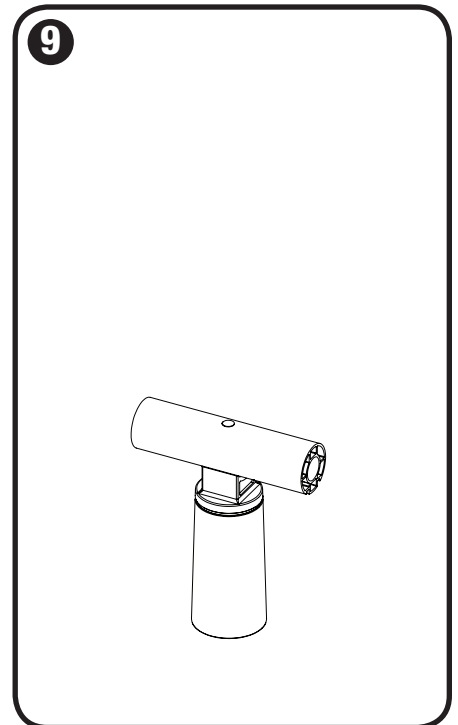

Secure seat rail

- Seat rail should now be secured to the mounting posts.

TECNO RS SEATING SYSTEM

SURFACE MOUNT WITHOUT BASE PLATE INSTALLATION INSTRUCTIONS

STEP BY STEP FOR SURFACE MOUNT CYLINDRICAL MOUNTING POST WITHOUT BASE PLATE.

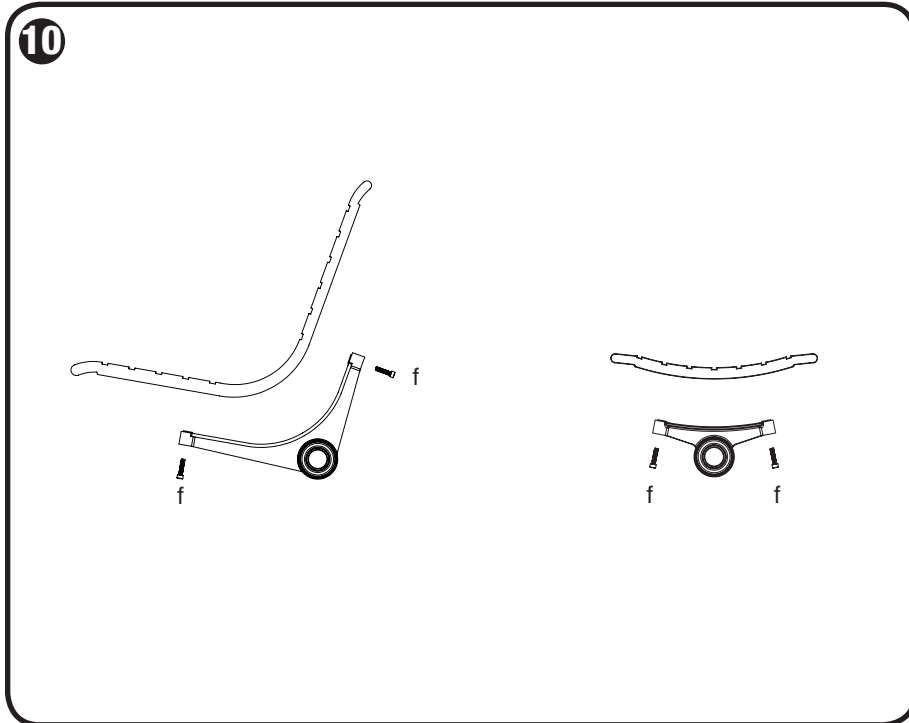

- Position backed seat on seat bracket ensuring that mounting holes line up.
- Insert M8 x 35 socket head cap screws (f) using a 6mm hex key to secure backed seat to seat bracket.
- Tighten screws until snug.

NOTE: Forms+Surfaces recommends applying Loctite® or similar thread-locking adhesive.