

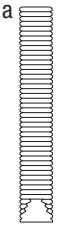







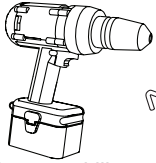

TWIST BIKE RACK

SURFACE MOUNT INSTALLATION INSTRUCTIONS

MATERIALS INCLUDED			TOOLS NEEDED				
							
							

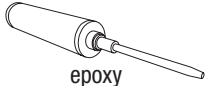
STEP BY STEP FOR ALL TWIST BIKE RACKS

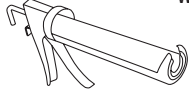
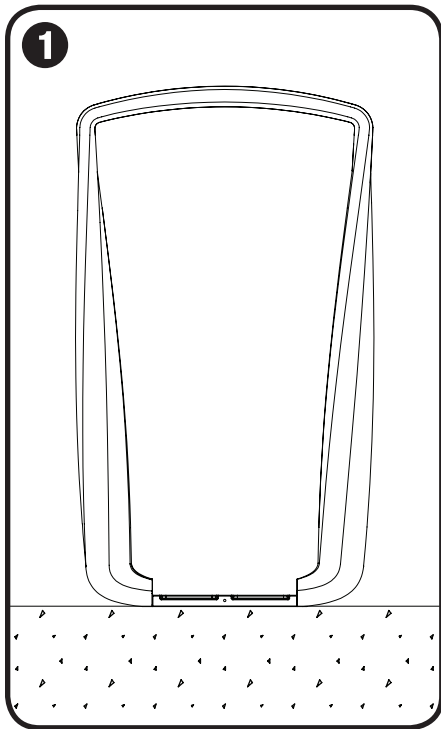

Mark hole locations

- Place bike rack in desired location ensuring stabilization. Mark center of each hole location with a pencil.

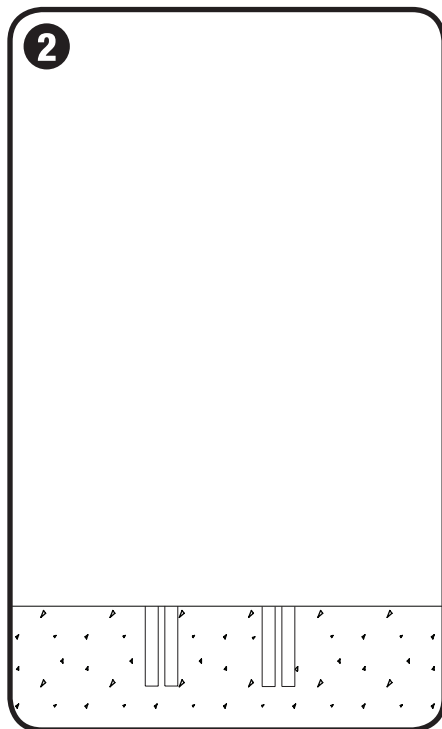

Drill holes

- Use hammer drill to drill 4.5" deep x 3/4" diameter anchor hole at each marked location using a 3/4" drill bit suitable for concrete drilling.

NOTE: Forms+Surfaces recommends starting holes with 1/4" diameter drill bit followed by 1/2" and finally 3/4" for maximum accuracy.

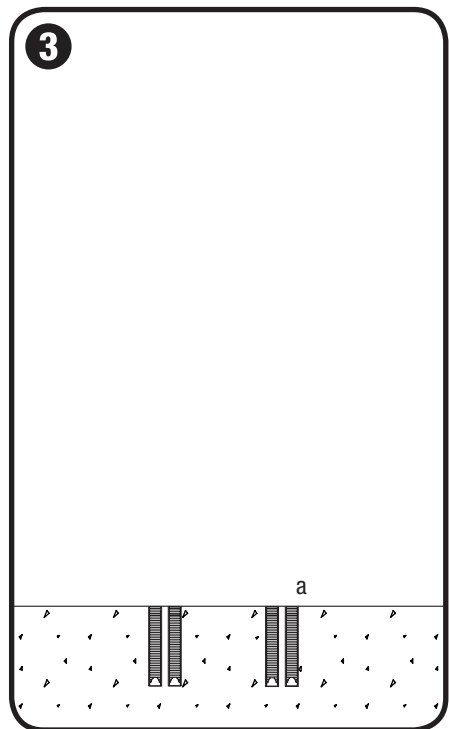

Fill holes & insert anchors

- Use compressed air and steel wire brush to clean each anchor hole in accordance with epoxy instructions.
- Use epoxy in epoxy gun to fill each anchor hole 5/8 of the hole depth in accordance with epoxy instructions.
- Insert 3/8" - 16 x 4-1/4" epoxy anchor (a) into each anchor hole so anchor top is flush with ground. Allow proper curing time according to cure schedule on epoxy instructions before moving on to Step 4.

TWIST BIKE RACK

STEP BY STEP FOR ALL TWIST BIKE RACKS

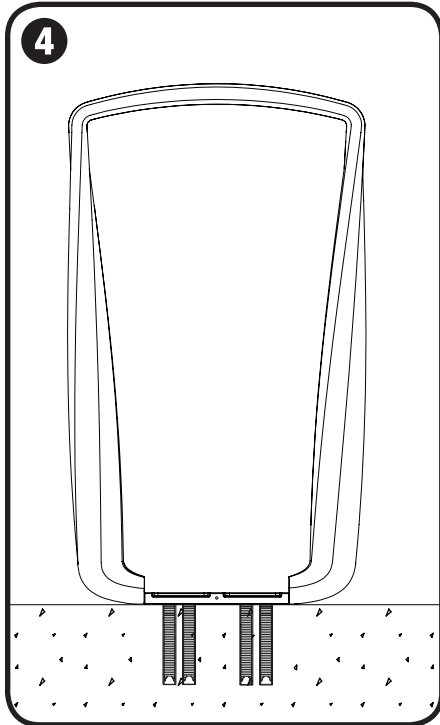

Position bike rack

- Position bike rack so that mounting holes line up with anchors.

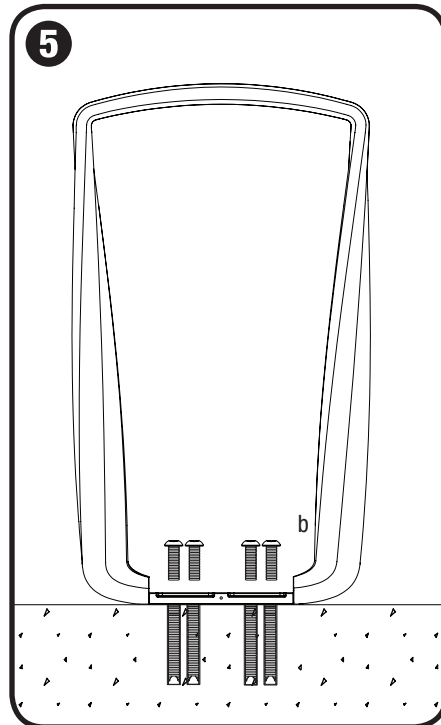

Attach bike rack and tighten screws

- Insert four 3/8"-16 x 1-1/2" button head cap screws (b) into mounting holes in bike rack. Thread anchors using provided 7/32" hex bit for tamper-resistant screws.
- Tighten all screws.

NOTE: Forms+Surfaces recommends applying Loctite® or similar thread-locking adhesive.

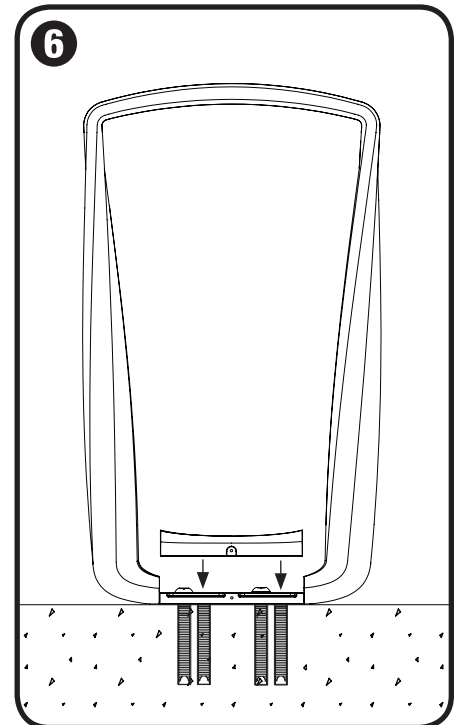

Slide cover plate over base of bike rack

TWIST BIKE RACK

STEP BY STEP FOR ALL TWIST BIKE RACKS

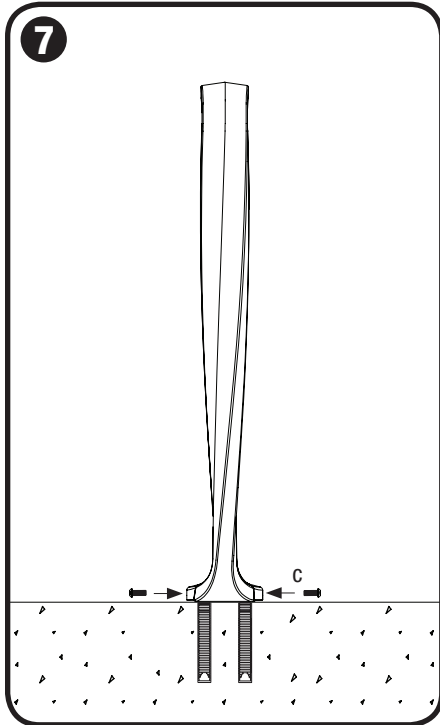

Attach cover plate and tighten screws

- Thread 10-24 x 1" button head screws (c) through each hole using provided 5/32" hex bit for tamper-resistant screws.
- Tighten all screws.

NOTE: Forms+Surfaces recommends applying Loctite® or similar thread-locking adhesive.

TWIST BIKE RACK

SURFACE MOUNT INSTALLATION INSTRUCTIONS

RECOMMENDED BICYCLE RACK SPACING PER ASSOCIATION OF PEDESTRIAN AND BICYCLE PROFESSIONALS (APBP) GUIDELINES FOR ALL TWIST BIKE RACKS

