

VECTOR SEATING SYSTEM

INSTALLATION INSTRUCTIONS

MATERIALS INCLUDED



epoxy



7/32" hex bit for tamper-resistant screws

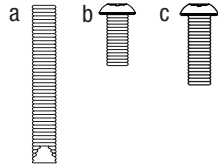

TOOLS NEEDED



pencil



1/4", 1/2" & 3/4" drill bits for concrete



ratchet

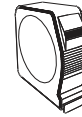

tape measure

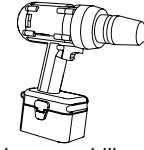

hammer drill

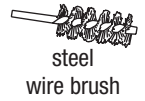

steel wire brush

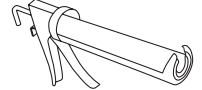

epoxy gun

STEP BY STEP FOR VECTOR SEATING SYSTEM CONFIGURATIONS WITH A STANDALONE BENCH

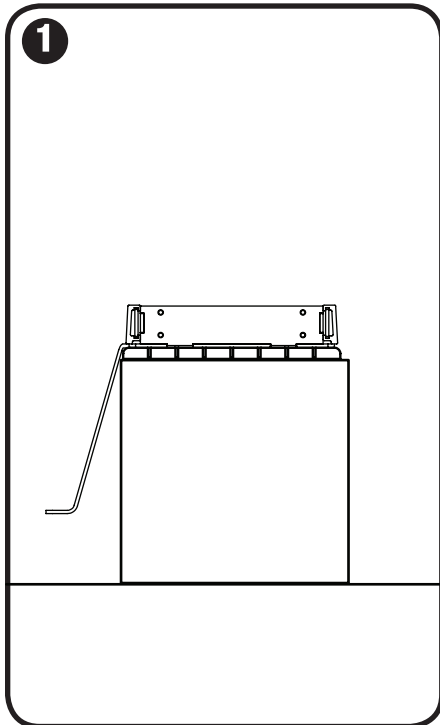

1 Place bench, top down

- Securely place bench, top down, on top of a padded surface.

Note: You will need to use a sturdy, elevated surface when attaching legs to a configuration with seat backs.

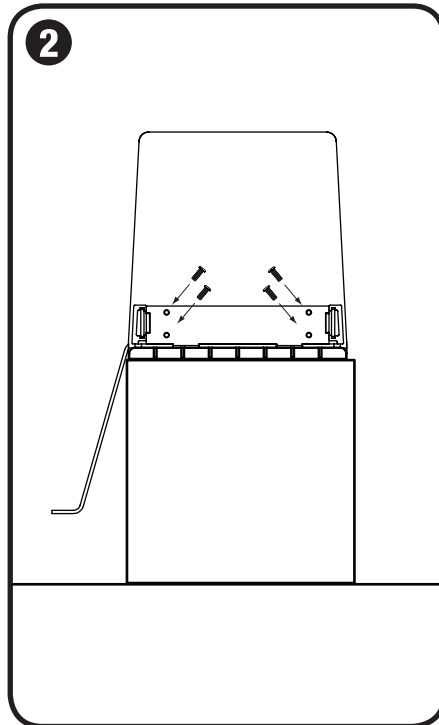

2 Attach legs

- Position leg with edge of bench seat.
- Insert 3/8" - 16 x 3/4" tamper-resistant button head cap screw (b) into mounting holes in bench and thread into holes using provided 7/32" hex bit for tamper-resistant screws.
- Repeat with all benches ensuring that end/intermediate legs are used appropriately.

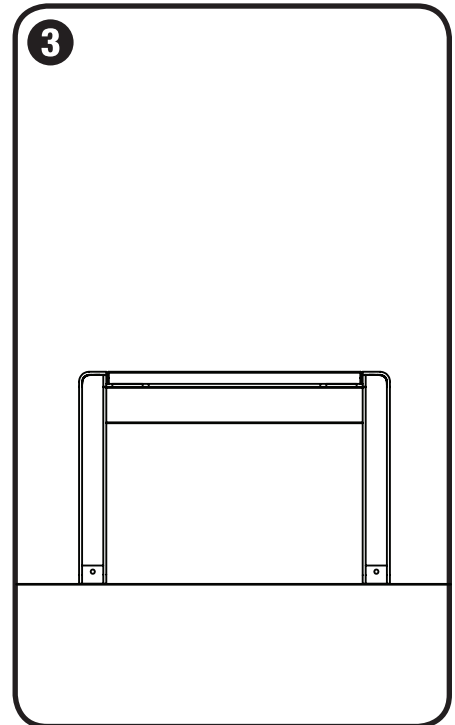

3 Position standalone bench

- Carefully turn bench right side up; use padding where necessary.
- Position bench in desired location. Be sure that the space allows enough room for full configuration.
- For freestanding configurations skip to step 11.

Note: Forms+Surfaces recommends using a sturdy box (or something similar) to help temporarily position add-on benches.

VECTOR SEATING SYSTEM

STEP BY STEP FOR VECTOR SEATING SYSTEM CONFIGURATIONS WITH A STANDALONE BENCH

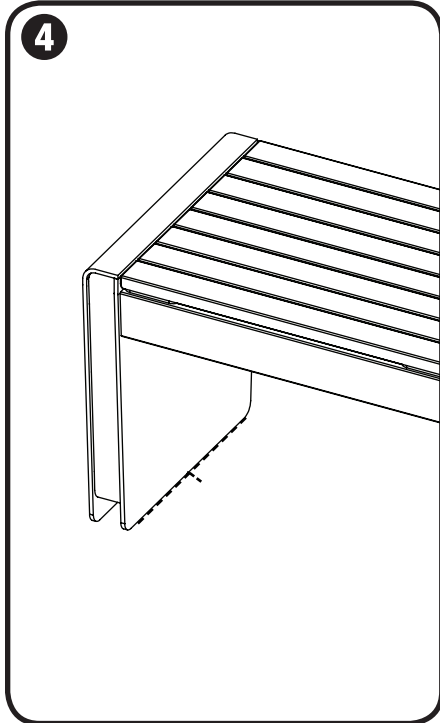

Mark surface mount location

- Once module is in the desired location, mark the ground along the inside of each leg including the center notch, indicated by the dashed line.
- Carefully move bench to the side once mounting surface is marked.
Note: Forms+Surfaces recommends using a sturdy box (or something similar) to help position add-on benches for this step.

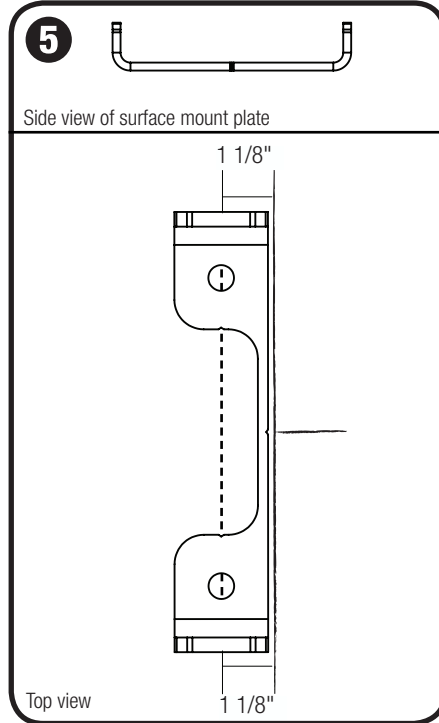

Position surface mount plate

- Measure and mark 1 1/8" from surface mount mark to find the surface mount plate center line, indicated by the dashed line.
- Position the surface mount plate by first aligning the center notch with the center notch line.
- Next, align the mounting holes and positioning notches to the surface mount plate center line.
- Mark the center of each mounting hole.

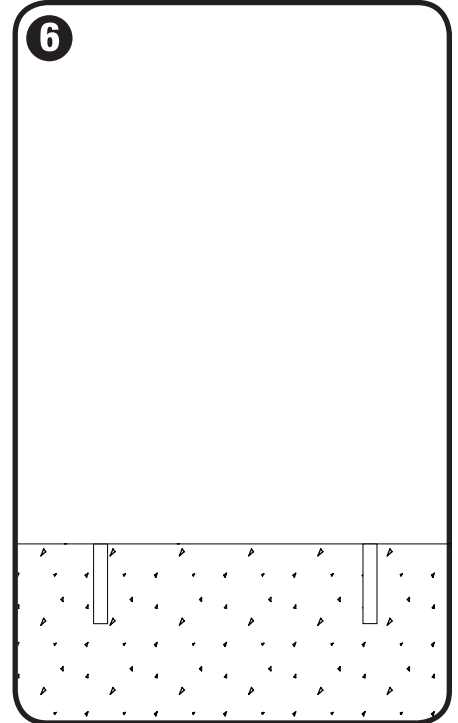

Drill holes

- Use hammer drill to drill 4.5" deep x 3/4" diameter anchor hole at each marked location using a 3/4" drill bit suitable for concrete drilling.
Note: Forms+Surfaces recommends starting holes with 1/4" diameter drill bit followed by 1/2" and finally 3/4" for maximum accuracy.

VECTOR SEATING SYSTEM

STEP BY STEP FOR VECTOR SEATING SYSTEM CONFIGURATIONS WITH A STANDALONE BENCH

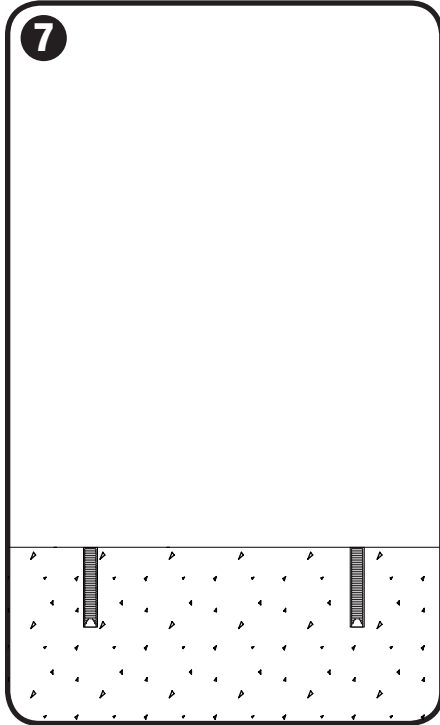

Fill holes & insert anchors

- Use compressed air and steel wire brush to clean each anchor hole in accordance with epoxy instructions.
- Use epoxy in epoxy gun to fill each anchor hole 5/8 of the hole depth in accordance with epoxy instructions
- Insert 3/8"-16 x 4-1/4" epoxy anchor (a) into each anchor hole so anchor top is flush with ground. Allow proper curing time according to cure schedule on epoxy instructions before moving on to Step 8.

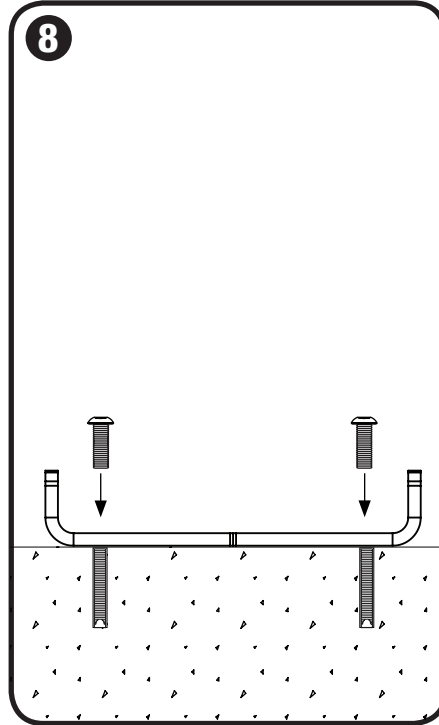

Attach surface mount plate

- Position surface mount plate so that mounting holes line up with anchors.
- Insert 3/8"-16 x 1-1/2" tamper-resistant button cap screws (c) into mounting holes in surface mount plate.

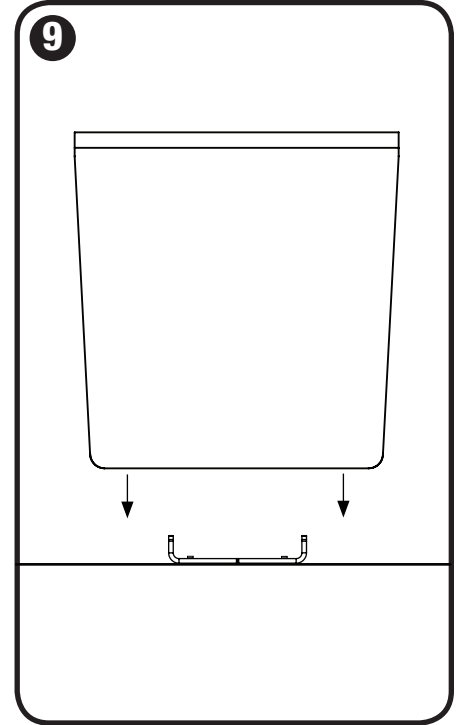

Fit module onto surface mount plate

- Lift module up and slide leg(s) onto mounted surface mount plate(s).

VECTOR SEATING SYSTEM

STEP BY STEP FOR VECTOR SEATING SYSTEM CONFIGURATIONS WITH A STANDALONE BENCH

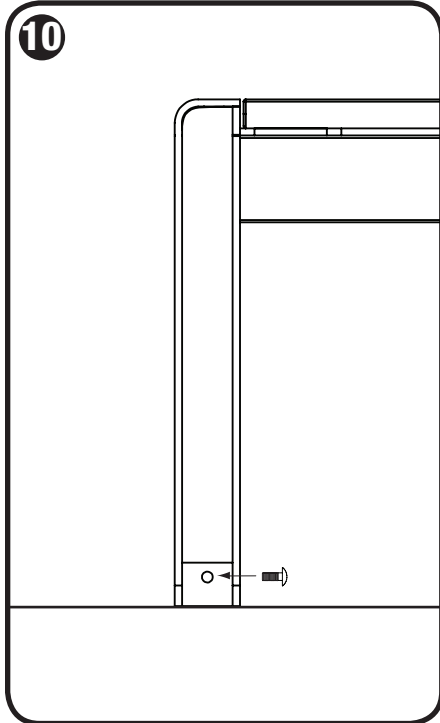

Attach leg to surface mount plate

- Ensure that leg mounting hole and surface mount plate mounting hole align.
- Insert 3/8"-16 x 3/4" tamper-resistant button head cap screw (b) into bench connection holes using provided 7/32" hex bit for tamper resistant screws.

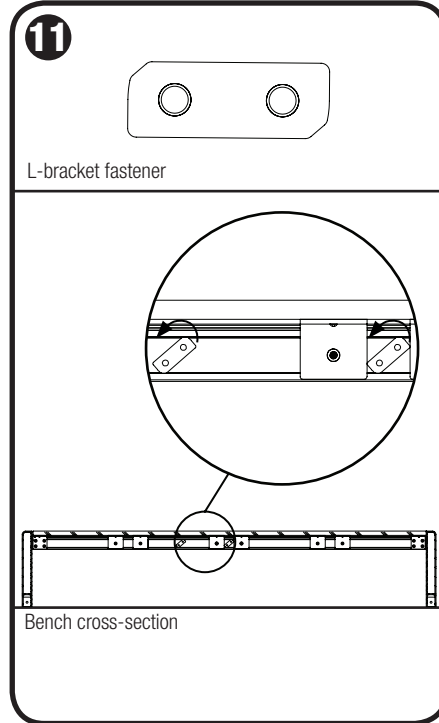

L-bracket fastener

Bench cross-section

Place L-bracket fasteners

- Identify add-on attachment location on receiving bench.
- Place L-bracket fasteners in the back of the receiving bench's side rail, approximately 11-3/4" apart from each other.
- Fit the fasteners horizontally and then turn to sit vertically in the rail as shown above.

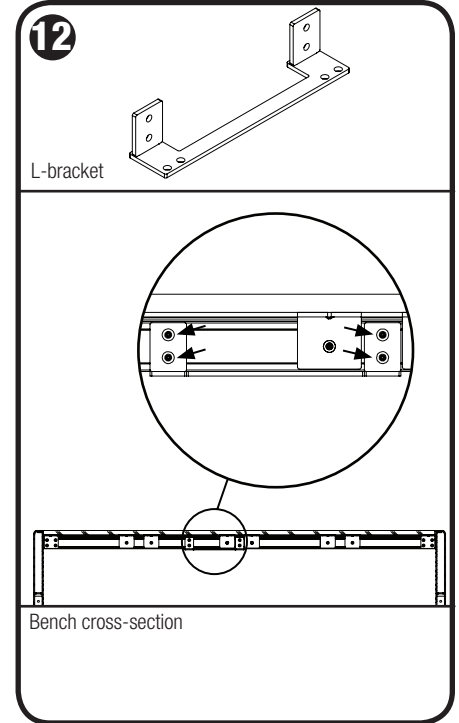

L-bracket

Bench cross-section

Attach L-bracket

- Align L-bracket tabs with L-bracket fastener mounting holes.
- Use 3/8"-16 x 3/4" tamper-resistant button head cap screw (b) to secure L-bracket to L-bracket fasteners using a 7/32" hex bit for tamper-resistant screws.

VECTOR SEATING SYSTEM

STEP BY STEP FOR VECTOR SEATING CONFIGURATIONS WITH A STANDALONE BENCH

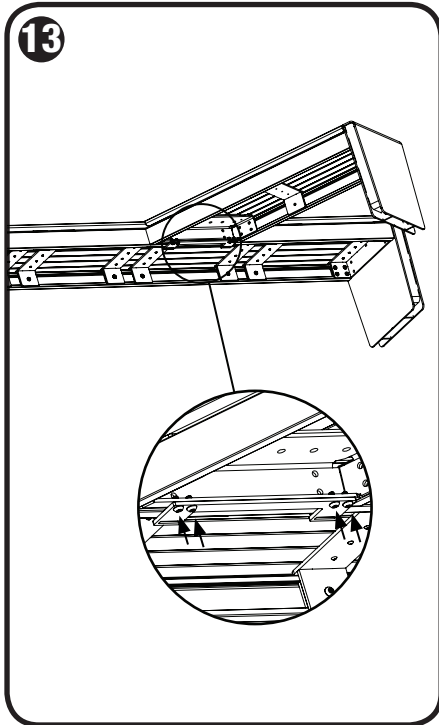

Attach add-on module

- Insert end tabs from add-on bench under the receiving bench seat slats. Ensure mounting holes from add-on bench line up with L-bracket mounting holes.
- Once connection holes are aligned insert 3/8"-16 x 3/4" tamper-resistant button head cap screw (b) into bench connection holes using provided 7/32" hex bit for tamper resistant screws.