

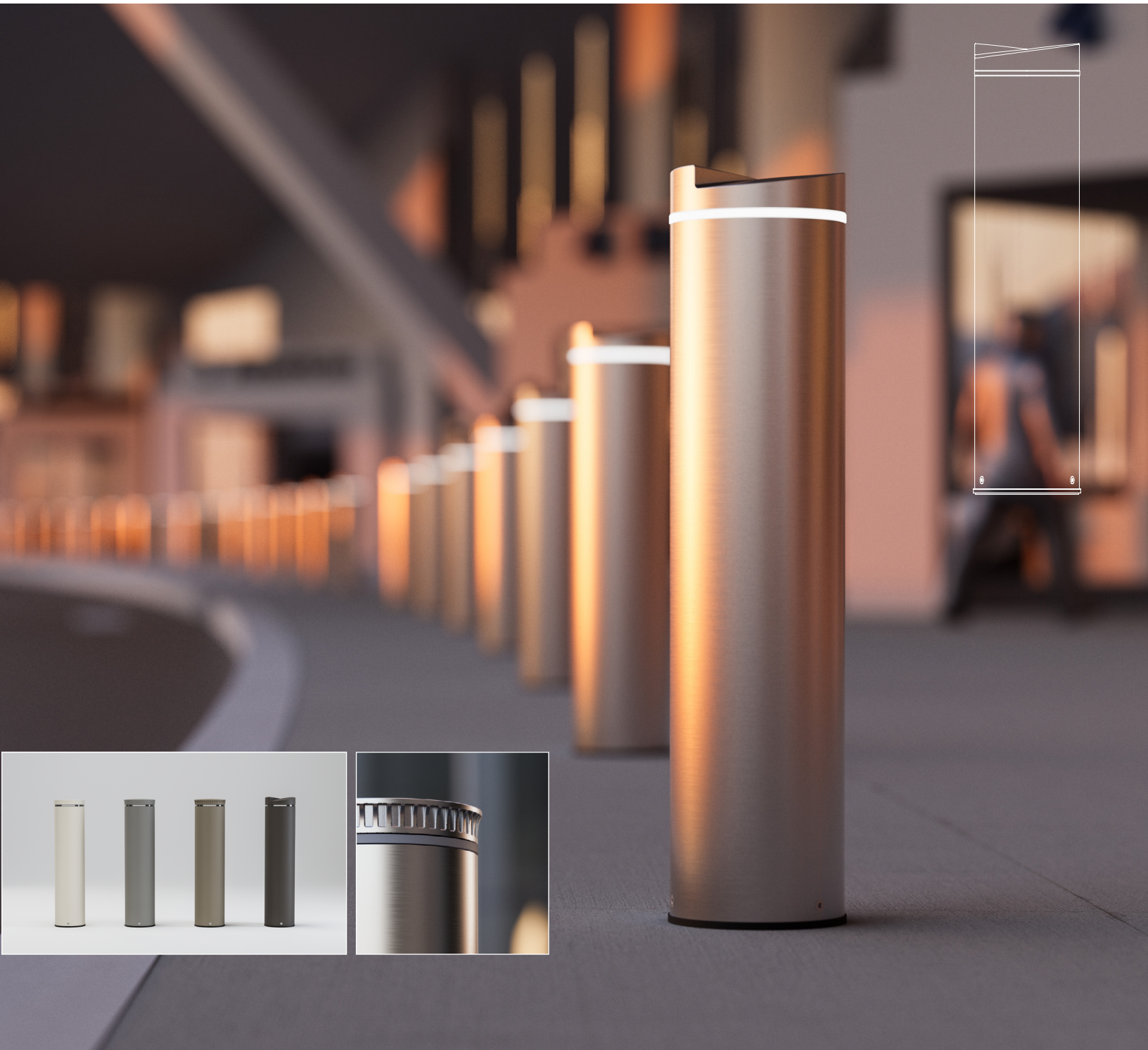

**CYRCA™** M30-P1/K4 SECURITY BOLLARD

PRODUCT DATA





## CYRCA™ M30-P1/K4 SECURITY BOLLARD

PRODUCT DATA

**Cyrca M30-P1/K4 Security Bollards** in stainless steel provide ambient lighting, robust protection, and a sleek design that seamlessly integrates into a wide range of environments. Fixtures 9.25" in diameter have an embedded security core and are available with or without illumination. Four cap designs readily coordinate with different site-specific aesthetics. Illuminated bollards feature 360° light distribution, Cree® LEDs in 3000K warm white and 4000K neutral white, and less than 5% upward lumen output. Non-illuminated bollards have a polished stainless steel ring detail that brings a refined finish to the end design.

### MATERIAL & CONSTRUCTION DETAILS

CONFIGURATIONS	LED LAMPS & DRIVER	INSTALLATION
<ul style="list-style-type: none"> <li>Cyrca Bollards are 40" high x 9.25" diameter.</li> <li>Cap options include the four designs shown below.</li> <li>Illuminated Cyrca Security Bollards have 360° light distribution.</li> <li>Non-illuminated Cyrca Security Bollards are available.</li> <li>Cyrca Bollards without security cores are also available in illuminated or non-illuminated versions.</li> </ul>	<ul style="list-style-type: none"> <li>Custom LED light engine with Cree® LEDs.</li> <li>3000K warm white and 4000K neutral white color temperatures.</li> <li>Less than 5% upward lumen output.</li> <li>LED driver input voltage is 120-277VAC, -30°C minimum starting temperature.</li> <li>Driver has reverse-phase, forward-phase, and 0-10V dimming capabilities.</li> <li>LED driver certifications include: IP64 enclosure and Class 2 rated output (UL8750).</li> </ul>	<ul style="list-style-type: none"> <li>Security bollards have embedded security cores and can use either of two mounting styles: deep set or shallow mount.</li> <li>Non-security bollards are surface mounted with J-bolts.</li> <li>Installation of a surge protector as part of each unit's wiring is recommended.</li> <li>Stainless steel mounting hardware sold separately. Templates are available upon request.</li> <li>See pages 2-4 for more information.</li> <li>Refer to installation instructions and foundation details for security rating requirements.</li> </ul>
MATERIALS & FINISHES		MAINTENANCE
<ul style="list-style-type: none"> <li>Illuminated bollards have a tubular stainless steel column, frosted acrylic lens, and stainless steel cap.</li> <li>Non-illuminated bollards have a tubular stainless steel column, polished stainless steel ring in place of the frosted acrylic lens, and stainless steel cap.</li> <li>Stainless steel is standard with a Satin finish and Ceramiloc treatment. See below for details.</li> <li>For optional powdercoat colors see the Forms+Surfaces Powdercoat Chart. Custom RAL colors are available for an upcharge.</li> </ul>		<ul style="list-style-type: none"> <li>Metal surfaces can be cleaned as needed using a soft cloth or brush with warm water and a mild detergent. Avoid abrasive cleaners.</li> </ul>

### CAP OPTIONS



Standard



Doric

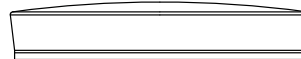

Flair



Rift

### CERAMILOC TREATMENT

Ceramiloc is an invisible surface treatment that offers significantly enhanced protection from weather and graffiti and increases the maintenance ease of stainless steel. Ceramiloc combines ceramic durability with an unparalleled ability to lock out water spots, fingerprints, graffiti and more. Patented technology bonds nano-silica particles to the surface of the stainless steel. The treatment minimally alters the surface appearance of the stainless and offers numerous benefits:

- Easily Cleaned:** The Ceramiloc treatment creates a surface that simultaneously resists fingerprints and is easy to clean. Water spots, grease marks and more can be quickly wiped away. It also creates an "anti-graffiti" surface – even permanent marker is easily removed with a clean microfiber towel and water.
- Durable:** Ceramiloc-treated materials are abrasion- and scratch-resistant. The treatment is permanent, UV stable, and will not degrade or discolor over time.
- Environmentally Sound:** The Ceramiloc treatment is a no-VOC, water-based process. Because Ceramiloc surfaces are so easily maintained, cleaning solutions and maintenance are kept to a minimum.

T 800.451.0410 | [www.forms-surfaces.com](http://www.forms-surfaces.com)

**FORMS+SURFACES®**

© 2023 Forms+Surfaces® | All dimensions are nominal. Specifications and pricing subject to change without notice. For the most current version of this document, please refer to our website at [www.forms-surfaces.com](http://www.forms-surfaces.com).



# CYRCA™ M30-P1/K4 SECURITY BOLLARD

PRODUCT DATA

## DEEP SET EMBEDDED M30-P1/K4 SECURITY CORE (STANDARD CAP SHOWN)

### ILLUMINATED BOLLARD

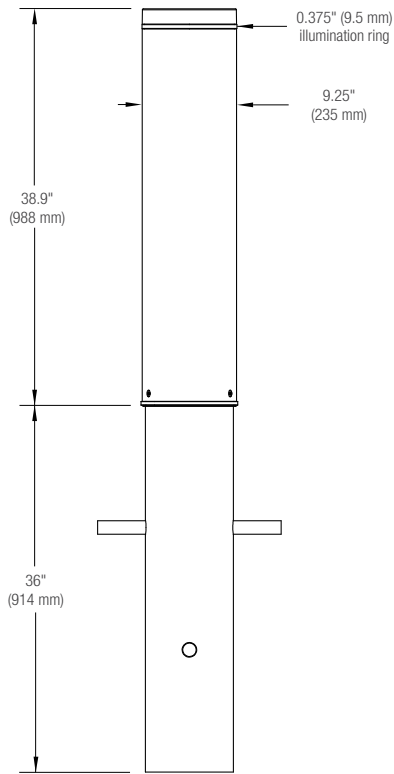

### NON-ILLUMINATED BOLLARD

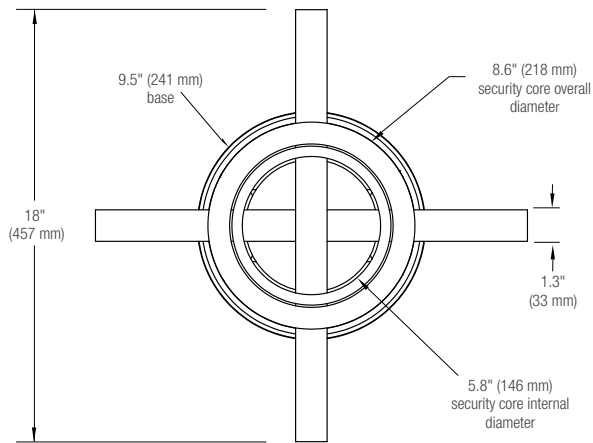
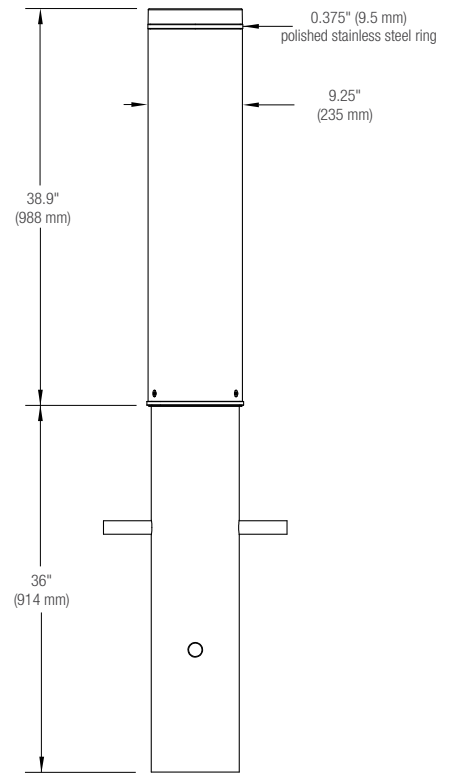



# CYRCA™ M30-P1/K4 SECURITY BOLLARD

PRODUCT DATA

## SHALLOW MOUNT EMBEDDED M30-P1/K4 SECURITY CORE (STANDARD CAP SHOWN)

### ILLUMINATED BOLLARD

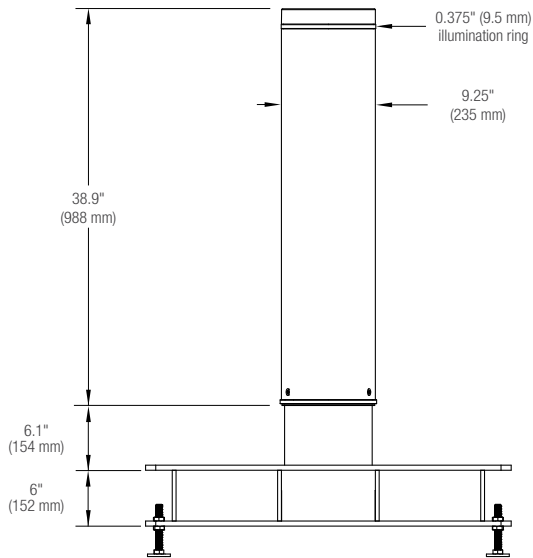

### NON-ILLUMINATED BOLLARD

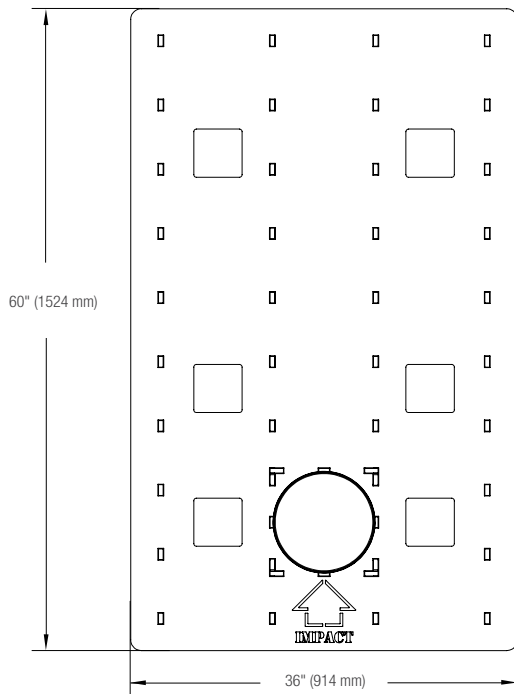
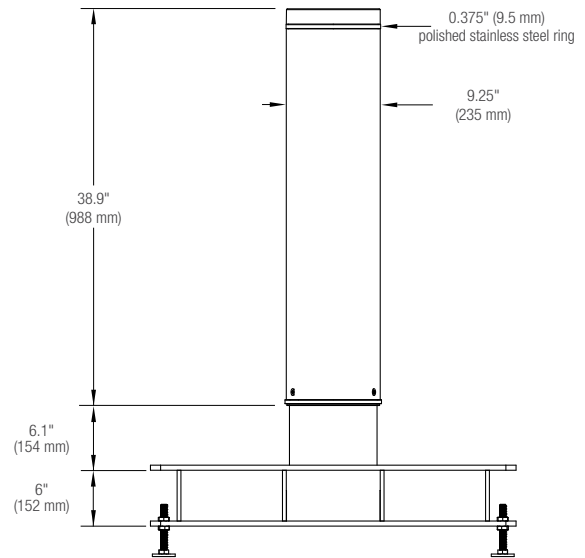



# CYRCA™ M30-P1/K4 SECURITY BOLLARD

PRODUCT DATA

## SURFACE MOUNT WITH J-BOLTS (NON-SECURITY, STANDARD CAP SHOWN)

### ILLUMINATED BOLLARD

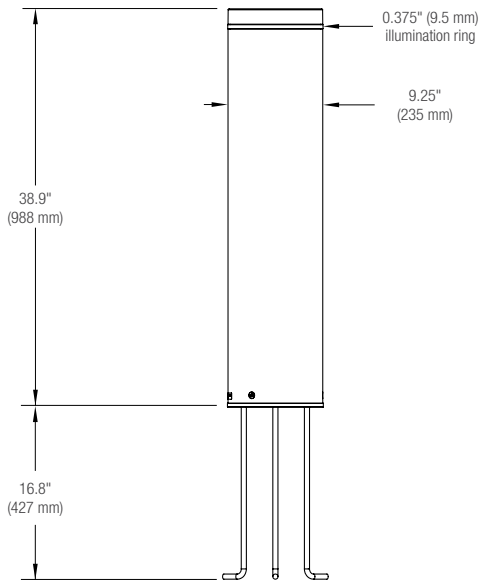

### NON-ILLUMINATED BOLLARD

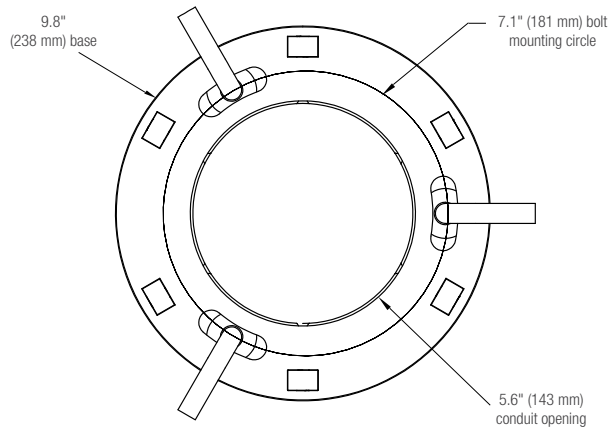
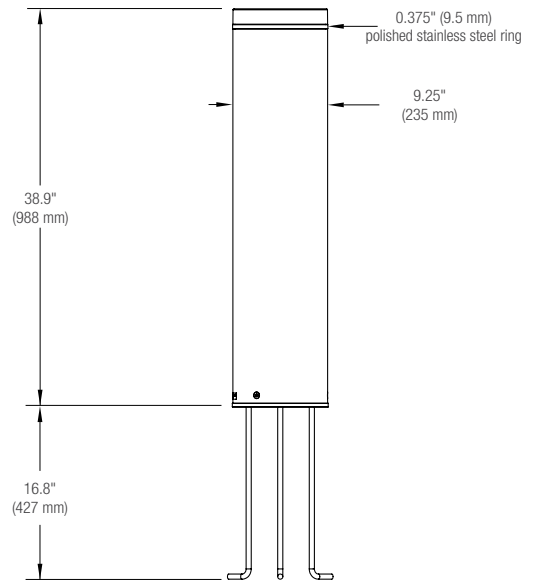



# CYRCA™ M30-P1/K4 SECURITY BOLLARD

PRODUCT DATA

## LIGHT ENGINE DESCRIPTION

LED ENGINE	LIGHT DISTRIBUTION	DESCRIPTION	LUMINAIRE LUMENS*	B.U.G. RATING
3000K LED	360°	10W LED driver	65	B0-U1-G0
4000K LED	360°	10W LED driver	65	B0-U1-G0

\*Luminaire lumens represent the absolute photometry for the luminaire, and indicates the lumens out of the entire fixture.

**NOTE:** Polar candela and isofootcandle plots can be found on the [Cyrca M30-P1/K4 Security Bollard product page](#) on our website.

## M30-P1/K4 SECURITY CORE

Site security is a major concern in today’s unpredictable world. Public and private buildings, government facilities, campuses and public parks are all susceptible to accidental, as well as deliberate, vehicle infringement. Design professionals, city planners, facilities managers and engineers must now be increasingly sensitive to the safety and security requirements of public and private spaces. Security bollards placed at ingress points are an excellent way to guard against vehicle infringement while allowing pedestrian access.

Most security bollards have taken the form of generic pipes and cylinders that offered little in the way of design or lighting functionality. Forms+Surfaces’ Cyrca M30-P1/K4 Security Bollards bring a pre-engineered and fully-tested security core to our Cyrca line to offer a beautiful and efficient lighting bollard that also meets the stringent high-impact crash requirements normally attained only with unattractive pipe barriers.

Forms+Surfaces’ security bollards have been tested using a Finite Element Analysis (FEA) by a professional engineering consultant. FEA is a software-based tool commonly used in the automotive industry and used extensively for crash test simulations. All of our bollards with the security solution option were tested and passed a very demanding set of impact criteria. Tests were performed using a bollard set in permanent concrete footings and struck by a vehicle at a 90-degree impact. The impact simulation found the bollards to be successful in stopping a 15,000 lb. vehicle traveling at a minimum test velocity of 30 mph in less than 3.3 feet (1 meter).

Please contact us to discuss design and installation considerations for Cyrca bollards with security cores.

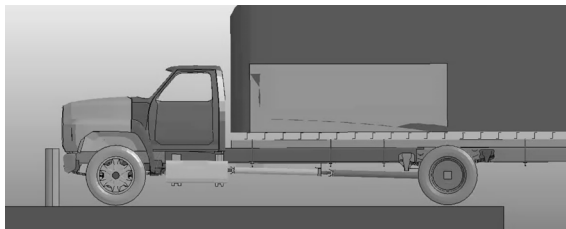

Crash scenario with 15,000 lb pickup truck approaching embedded bollard system at 30 mph

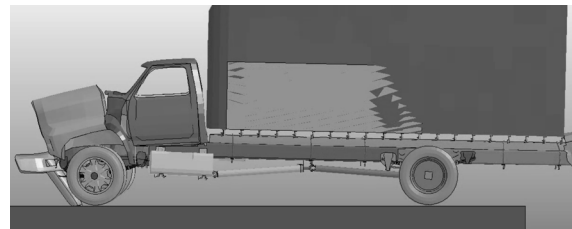

Full-scale crash immediately after impact

## CERTIFICATION

- ETL and C-ETL listed for wet locations.

## ENVIRONMENTAL CONSIDERATIONS

- Please refer to the Cyrca M30-P1/K4 Security Bollard Environmental Data Sheet for detailed environmental impact information.
- Metal components have a long life cycle and are 100% recyclable.
- Standard powdercoat finishes are no-VOC; non-standard powdercoat finishes are no- or low-VOC, depending on color.
- Low maintenance.



## CYRCA™ M30-P1/K4 SECURITY BOLLARD

PRODUCT DATA

### MODEL NUMBERS AND DESCRIPTIONS

MODEL	DESCRIPTION
LBCYR-903	Cyrca M30-P1/K4 Security Bollard illuminated
LBCYR-903-N	Cyrca M30-P1/K4 Security Bollard non-illuminated

### PRODUCT OPTIONS

The following options are available for an upcharge

Add powdercoat color from Forms+Surfaces Powdercoat Chart	Custom RAL powdercoat color
Add stainless steel mounting hardware	

**LEAD TIME:** 6 to 8 weeks. Shorter lead times may be available upon request. Please contact us to discuss your specific timing requirements.

**PRICING:** Please contact us at **800.451.0410** or **sales@forms-surfaces.com**. At Forms+Surfaces, we design, manufacture and sell our products directly to you. Our sales team is available to assist you with questions about our products, requests for quotes, and orders. Territory Managers are located worldwide to assist with the front-end specification and quoting process, and our in-house Project Sales Coordinators follow your project through from the time you place an order to shipment.

**TO ORDER SPECIFY:** Quantity, model, finish, LED color temperature, light distribution, and mounting. Quote/Order Forms are available on our website to lead you through the specification process in a simple checkbox format.