

PROJECT NAME: _____

DATE: _____

JOB LOCATION: _____

COMPANY: _____

SPECIFIER: _____

PLEASE USE ADOBE READER OR ADOBE ACROBAT TO FILL OUT AND SAVE FORM. USING OTHER PROGRAMS COULD RESULT IN UNSAVED DATA.

MODEL

QUANTITY	MODEL	
_____	SBKNI-072B	Knight Bench, FSC® 100% Cumaru hardwood slats, 6 foot, backed
_____	SBKNI-072N	Knight Bench, FSC® 100% Cumaru hardwood slats, 6 foot, backless
_____	SBKNI-096B	Knight Bench, FSC® 100% Cumaru hardwood slats, 8 foot, backed
_____	SBKNI-096N	Knight Bench, FSC® 100% Cumaru hardwood slats, 8 foot, backless
_____	SBKNI-072BT	Knight Bench, FSC® Recycled 100% Teak hardwood slats, 6 foot, backed
_____	SBKNI-072NT	Knight Bench, FSC® Recycled 100% Teak hardwood slats, 6 foot, backless
_____	SBKNI-072BA	Knight Bench, extruded aluminum slats, 6 foot, backed
_____	SBKNI-072NA	Knight Bench, extruded aluminum slats, 6 foot, backless
_____	SBKNI-096BA	Knight Bench, extruded aluminum slats, 8 foot, backed
_____	SBKNI-096NA	Knight Bench, extruded aluminum slats, 8 foot, backless
_____	SBKNI-072B-W	Knight Bench, FSC® 100% Cumaru hardwood slats, 6 foot, backed, wall-top mount
_____	SBKNI-072N-W	Knight Bench, FSC® 100% Cumaru hardwood slats, 6 foot, backless, wall-top mount
_____	SBKNI-096B-W	Knight Bench, FSC® 100% Cumaru hardwood slats, 8 foot, backed, wall-top mount
_____	SBKNI-096N-W	Knight Bench, FSC® 100% Cumaru hardwood slats, 8 foot, backless, wall-top mount
_____	SBKNI-072BT-W	Knight Bench, FSC® Recycled 100% Teak hardwood slats, 6 foot, backed, wall-top mount
_____	SBKNI-072NT-W	Knight Bench, FSC® Recycled 100% Teak hardwood slats, 6 foot, backless, wall-top mount
_____	SBKNI-072BA-W	Knight Bench, extruded aluminum slats, 6 foot, backed, wall-top mount
_____	SBKNI-072NA-W	Knight Bench, extruded aluminum slats, 6 foot, backless, wall-top mount
_____	SBKNI-096BA-W	Knight Bench, extruded aluminum slats, 8 foot, backed, wall-top mount
_____	SBKNI-096NA-W	Knight Bench, extruded aluminum slats, 8 foot, backless, wall-top mount

FSC License Code: FSC-C004453

OPTIONS

KNIGHT BENCH, 6-FOOT, BACKED

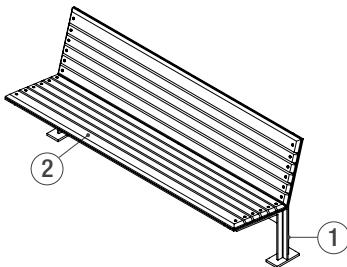

KNIGHT BENCH, 8-FOOT, BACKLESS, 3 ARMRESTS

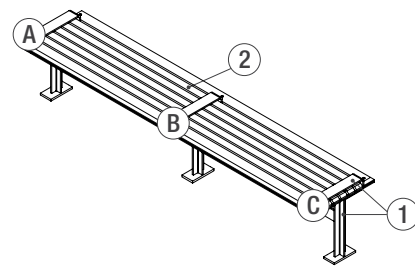

KNIGHT BENCH, 6-FOOT, BACKED, WALL-TOP MOUNT

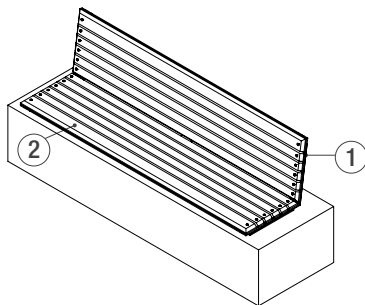

KNIGHT BENCH, 8-FOOT, BACKLESS, WALL-TOP MOUNT

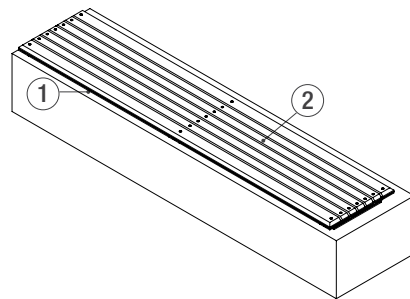

①

Frame/Armrest Powdercoat Colors

Please select **one** powdercoat color

Standard Texture from Forms+Surfaces Powdercoat Chart

- | | |
|------------------------------|----------------------------|
| Alabaster Texture | Dark Corten Texture |
| Aluminum Texture | Dark Grey Metallic Texture |
| Argento Texture | Deep Ocean Texture |
| Aubergine Texture | Ink Blue Texture |
| Black Texture | Moss Texture |
| Clay Texture | Silver Texture |
| Cool Grey Texture | Slate Texture |
| Dark Bronze Metallic Texture | White Texture |

Custom RAL Powdercoat Color

(please call for pricing information)

RAL Color _____

②

Aluminum Slat Powdercoat Colors

Please select **one** powdercoat color

Standard Texture from Forms+Surfaces Powdercoat Chart

- | | |
|------------------------------|----------------------------|
| Alabaster Texture | Dark Corten Texture |
| Aluminum Texture | Dark Grey Metallic Texture |
| Argento Texture | Deep Ocean Texture |
| Aubergine Texture | Ink Blue Texture |
| Black Texture | Moss Texture |
| Clay Texture | Silver Texture |
| Cool Grey Texture | Slate Texture |
| Dark Bronze Metallic Texture | White Texture |

Custom RAL Powdercoat Color

(please call for pricing information)

RAL Color _____

Armrest Options

Armrests Yes No

If "Yes," please specify locations below

Location(s)*: A & C B

**See example on Page 1*

Surface Mount Hardware Options

- Add F+S stainless steel mounting hardware kit
- Do not include F+S mounting hardware kit

**Hardware is required for surface mount benches. Mounting kits can be purchased from F+S for an additional charge.*

NOTES

Please send completed forms to sales@forms-surfaces.com or contact us at **800.451.0410** with any questions.