

PROJECT NAME: \_\_\_\_\_

DATE: \_\_\_\_\_

JOB LOCATION: \_\_\_\_\_

COMPANY: \_\_\_\_\_

SPECIFIER: \_\_\_\_\_

PLEASE USE ADOBE READER OR ADOBE ACROBAT TO FILL OUT AND SAVE FORM. USING OTHER PROGRAMS COULD RESULT IN UNSAVED DATA.

**MODEL**

**QUANTITY**

**MODEL**

|       |               |   |
|-------|---------------|---|
| _____ | STVTR-72C     | Vector Table Ensemble, FSC 100% Cumaru hardwood slats             |
| _____ | STVTR-72C-ADA | Vector Table Ensemble, ADA option, FSC 100% Cumaru hardwood slats |
| _____ | STVTR-72A     | Vector Table Ensemble, extruded aluminum slats                    |
| _____ | STVTR-72A-ADA | Vector Table Ensemble, ADA option, extruded aluminum slats        |

**OPTIONS**

**VECTOR TABLE ENSEMBLE**

*Shown with optional seat backs*

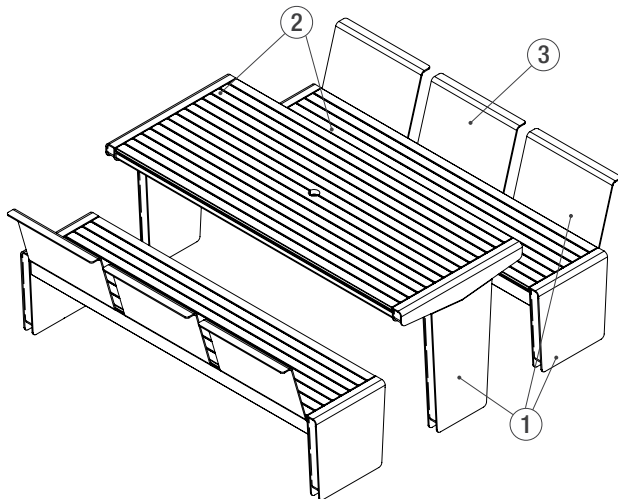

**VECTOR TABLE ENSEMBLE, ADA OPTION**

*Shown with optional seat backs*

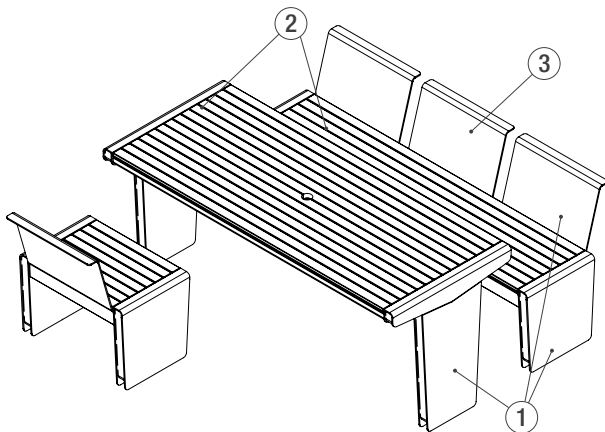

①

**Frame Powdercoat Colors**

Please select **one** powdercoat color.

*NOTE: Due to the inherent nature of metal castings, gloss powdercoats are not offered for cast components.*

**Standard Texture from Forms+Surfaces Powdercoat Chart**

- |   |   |
|---|---|
| <input type="checkbox"/> Alabaster Texture            | <input type="checkbox"/> Dark Corten Texture        |
| <input type="checkbox"/> Aluminum Texture             | <input type="checkbox"/> Dark Grey Metallic Texture |
| <input type="checkbox"/> Argento Texture              | <input type="checkbox"/> Deep Ocean Texture         |
| <input type="checkbox"/> Aubergine Texture            | <input type="checkbox"/> Ink Blue Texture           |
| <input type="checkbox"/> Black Texture                | <input type="checkbox"/> Moss Texture               |
| <input type="checkbox"/> Clay Texture                 | <input type="checkbox"/> Silver Texture             |
| <input type="checkbox"/> Cool Grey Texture            | <input type="checkbox"/> Slate Texture              |
| <input type="checkbox"/> Dark Bronze Metallic Texture | <input type="checkbox"/> White Texture              |

**Custom RAL Powdercoat Color**

*(please call for pricing information)*

RAL Color: \_\_\_\_\_

2

**Slat Color Options** (for models with aluminum slats)

Please select a powdercoat option.

**Standard Texture from Forms+Surfaces Powdercoat Chart**

- Alabaster Texture
- Aluminum Texture
- Argento Texture
- Aubergine Texture
- Black Texture
- Clay Texture
- Cool Grey Texture
- Dark Bronze Metallic Texture
- Dark Corten Texture
- Dark Grey Metallic Texture
- Deep Ocean Texture
- Ink Blue Texture
- Moss Texture
- Silver Texture
- Slate Texture
- White Texture

**Custom RAL Powdercoat Color**

(please call for pricing information)

- RAL Color: \_\_\_\_\_

**Umbrella Hole and Sleeve**

For use with the Soleris Sunshade

- Umbrella Hole and Sleeve     Yes     No  
 (subject to upcharge)

**Surface Mount Hardware Options**

- Add F+S stainless steel mounting hardware kit\*
- Do not include F+S mounting hardware kit

\*Hardware is required for surface mount tables & chairs. Mounting kits can be purchased from F+S for an additional charge.

**NOTES**

---



---



---

Please send completed forms to [sales@forms-surfaces.com](mailto:sales@forms-surfaces.com) or contact us at 800.451.0410 with any questions.

FSC License Code: FSC-C004453

T 800.451.0410 | [www.forms-surfaces.com](http://www.forms-surfaces.com)

**FORMS+SURFACES®**

© 2022 Forms+Surfaces® | All dimensions are nominal. Specifications and pricing subject to change without notice. For the most current version of this document, please refer to our website at [www.forms-surfaces.com](http://www.forms-surfaces.com).

3

**Seat Backs**

Please select **one** seat back option below.

Please note that seat backs cannot be placed at all connection points

- No seat back
- One seat back per 2-foot bench section

Quantity \_\_\_\_\_ (subject to upcharge)

Placement Notes: \_\_\_\_\_

\_\_\_\_\_

\_\_\_\_\_

**Mounting Options**

Table is surface mounted. Please select **one** mounting option for benches.

- Surface mount (benches with seat backs must be surface mounted)
- Freestanding