

8 7 6 5 4 3 2 1

D

D

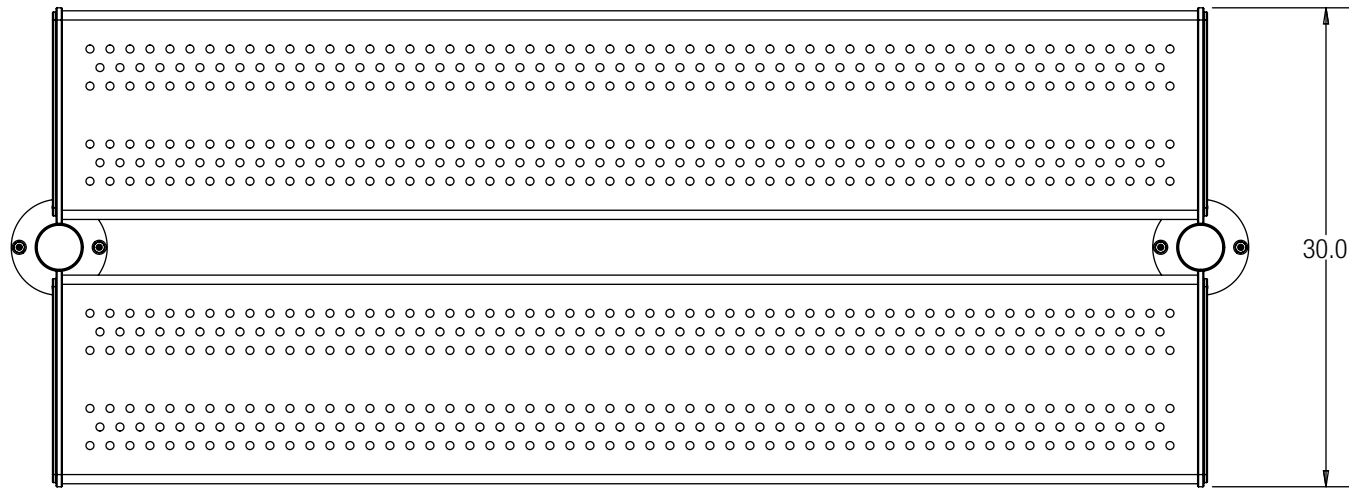

C

C

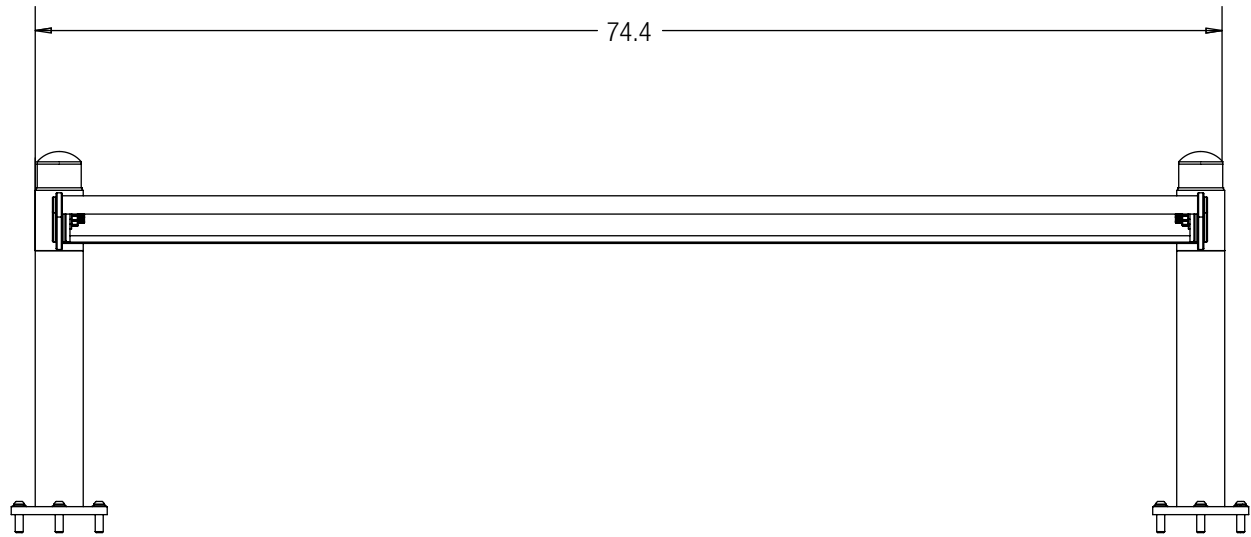

B

B

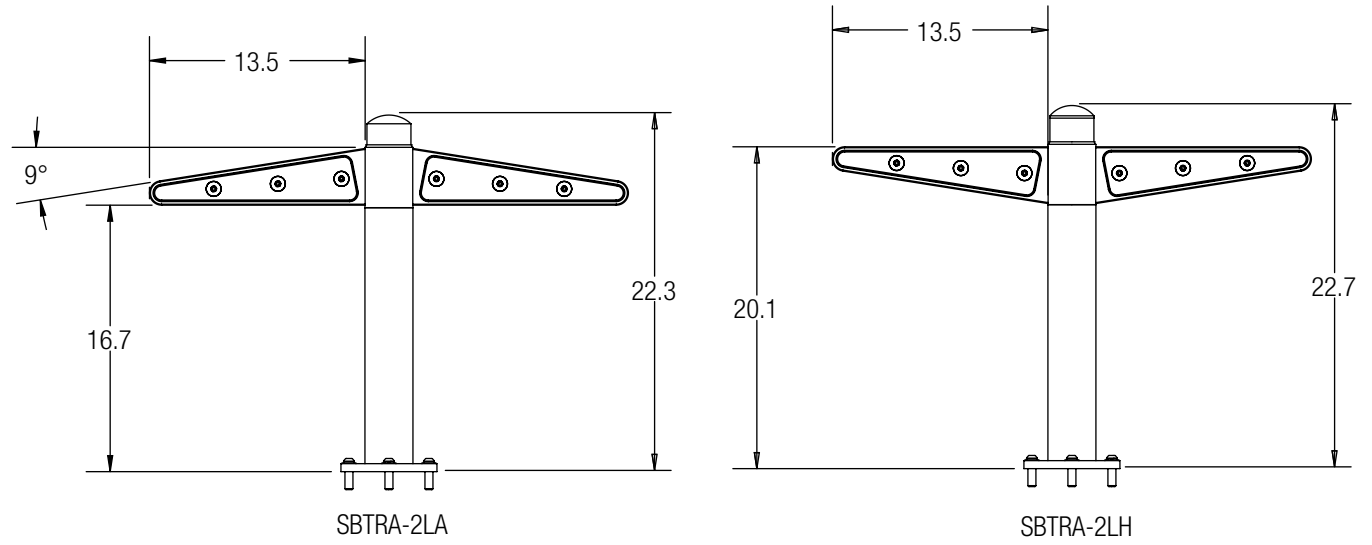

A

A

CUSTOMER APPROVAL:

X \_\_\_\_\_

DATE:

X \_\_\_\_\_

UNLESS OTHERWISE SPECIFIED, DIMENSIONS ARE IN INCHES		<b>FORMS+SURFACES</b> ® 30 Pine Street, Pittsburgh, PA 15223 Tel (800) 451-0410 Fax (412) 781-7840	
TOLERANCES (UNLESS OTHERWISE SPECIFIED): FRACTIONAL: ±1/32 ANGULAR/BEND: ±1° TWO PLACE DECIMAL ±.030 THREE PLACE DECIMAL ±.020		DATE	
MATERIAL: SEE DATA SHEET		9/17/2010	
FINISH: SEE DATA SHEET	DO NOT SCALE DRAWING		
WEIGHT: 128.7 LBS.	PROPRIETARY AND CONFIDENTIAL		
SOURCE: M	THE INFORMATION CONTAINED IN THIS DRAWING IS THE SOLE PROPERTY OF FORMS + SURFACES. ANY REPRODUCTION IN PART OR AS A WHOLE WITHOUT WRITTEN PERMISSION IS PROHIBITED.		
SCALE: N.T.S.			
		TRANSIT, DOUBLE, BACKLESS, ANGLED SBTRA-2LA (SURFACE MOUNT)	
		TRANSIT, DOUBLE, BACKLESS, HORIZ. SBTRA-2LH (SURFACE MOUNT)	
SIZE	DWG. NO.	REV	SHEET
B	SBTRA-2LA/H-SM-TD	0	1 OF 1

8 7 6 5 4 3 2 1