

8 7 6 5 4 3 2 1

D

D

C

C

B

B

A

A

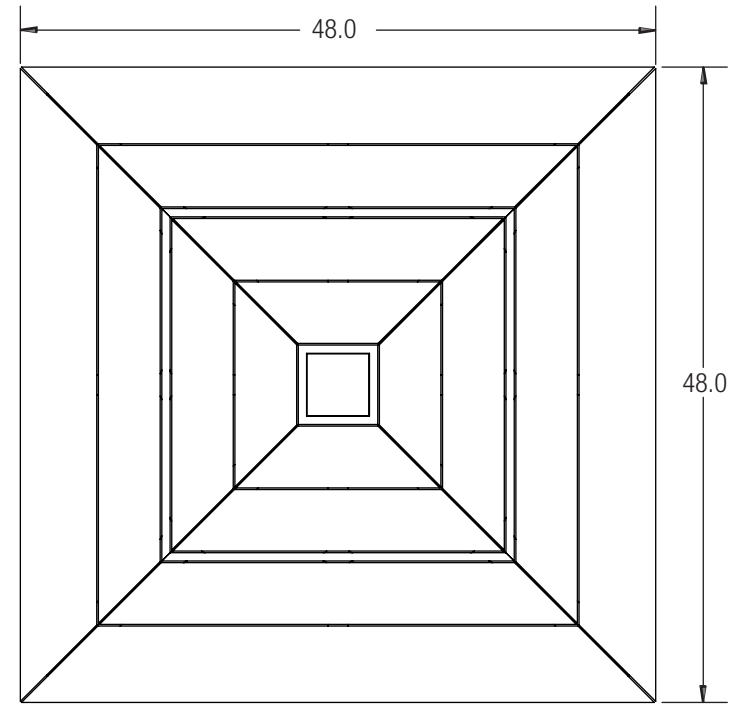
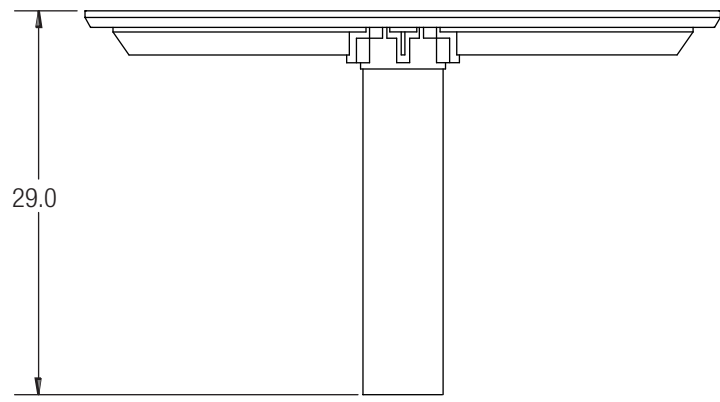

CUSTOMER APPROVAL:

X _____

DATE:

X _____

UNLESS OTHERWISE SPECIFIED,
DIMENSIONS ARE IN INCHES

TOLERANCES (UNLESS OTHERWISE SPECIFIED):
 FRACTIONAL: $\pm 1/32$
 ANGULAR/BEND: $\pm 1^\circ$
 TWO PLACE DECIMAL $\pm .030$
 THREE PLACE DECIMAL $\pm .020$

MATERIAL: SEE DATA SHEET

FINISH: SEE DATA SHEET

WEIGHT: 192 LBS.

SOURCE: M

SCALE: N.T.S.

FORMS+SURFACES® 30 Pine Street, Pittsburgh, PA 15223
 Tel (800) 451-0410 Fax (412) 781-7840

DATE
10/28/2011

DO NOT SCALE DRAWING

PROPRIETARY AND CONFIDENTIAL
 THE INFORMATION CONTAINED IN THIS DRAWING IS THE SOLE PROPERTY OF FORMS + SURFACES. ANY REPRODUCTION IN PART OR AS A WHOLE WITHOUT WRITTEN PERMISSION IS PROHIBITED.

APEX TABLE
 STAPX-OB

SIZE	DWG. NO.	REV	SHEET
B	STAPX-OB	0	1 OF 1

8 7 6 5 4 3 2 1