

8 7 6 5 4 3 2 1

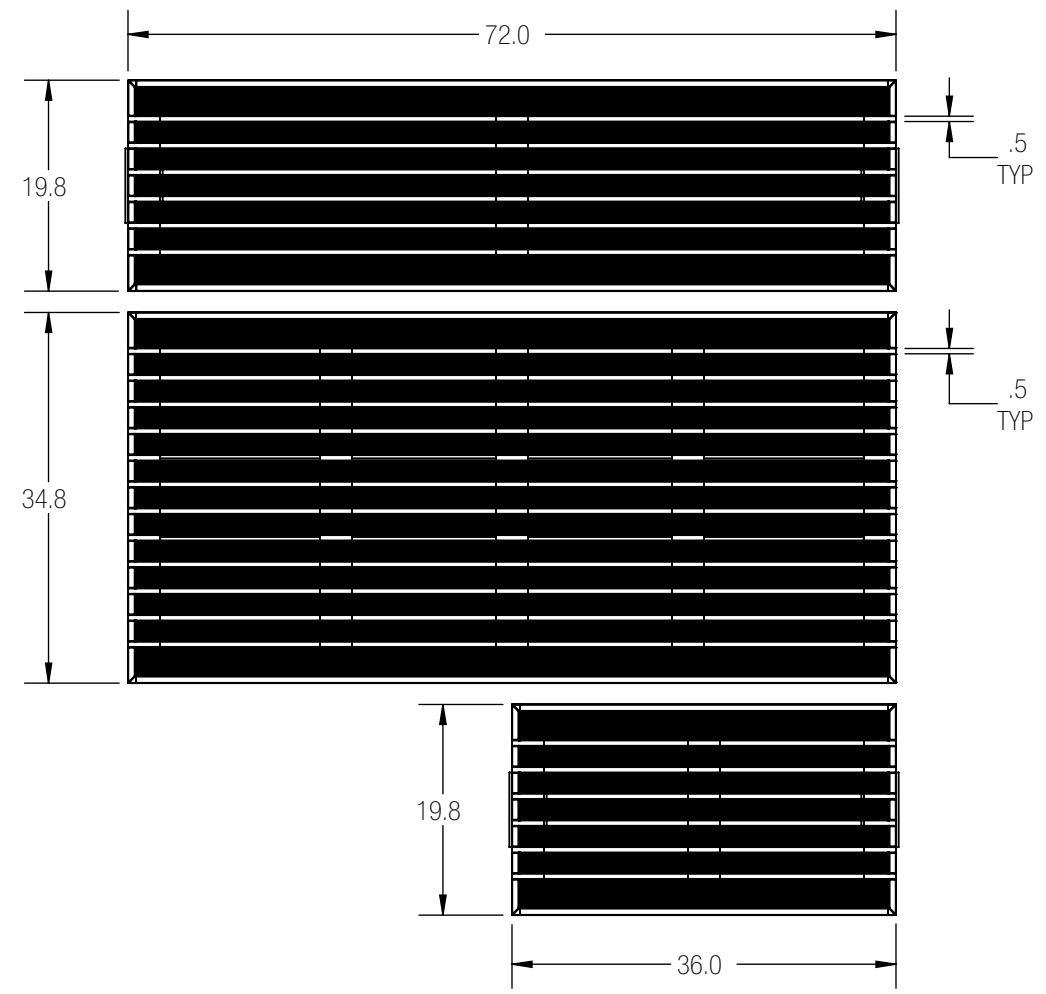

TOP VIEW

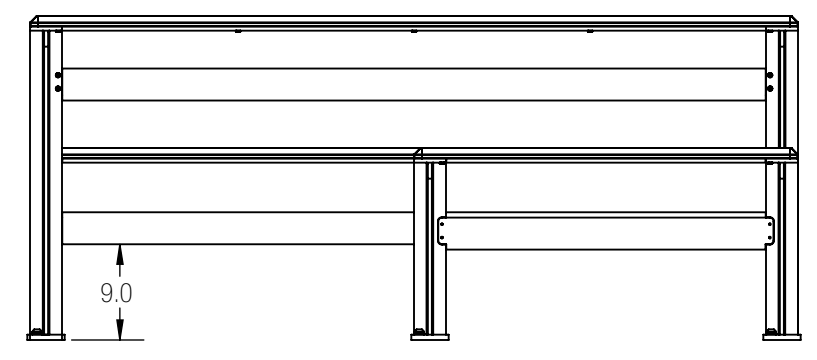

FRONT VIEW

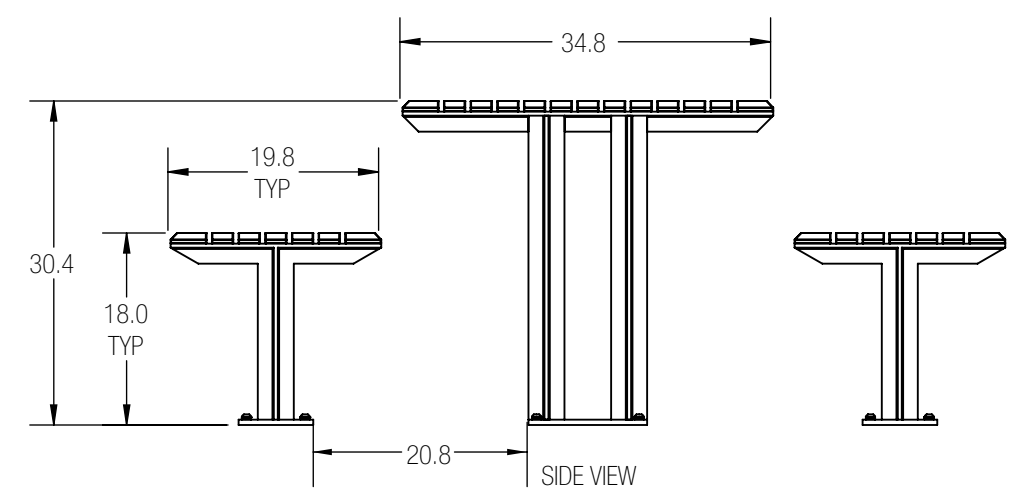

SIDE VIEW

UNLESS OTHERWISE SPECIFIED:  
 1. PRIMARY DIM. ARE IN INCHES & SECONDARY [DIM] IN MM  
 2. TOLERANCES  
 FRACTIONAL: ±1/32; ANGULAR/BEND: ±1°  
 TWO PLACE DECIMAL ±.030  
 THREE PLACE DECIMAL ±.020  
 3. REMOVE ALL BURRS AND SHARP EDGES

THIRD ANGLE PROJECTION

MATERIAL: REFER SO  
 FINISH: - REFER SO  
 WEIGHT: - 350.00 LBS.  
 SCALE: N.T.S

**FORMS+SURFACES** 30 Pine Street, Pittsburgh, PA 15223  
 Tel (412) 781-9003 Fax (412) 781-7840

NAME	DATE	DESCRIPTION:
DWN MGJ	04/23/2018	KNIGHT TABLE ENSEMBLE ADA, BACKLESS, ALUMINUM SLATS STKNI-72NA-ADA
RVS ARS	09/26/2018	

DO NOT SCALE DRAWING

PROPRIETARY AND CONFIDENTIAL  
 THE INFORMATION CONTAINED IN THIS DRAWING IS THE SOLE PROPERTY OF FORMS + SURFACES. ANY REPRODUCTION IN PART OR AS A WHOLE WITHOUT WRITTEN PERMISSION IS PROHIBITED.

SIZE	DWG. NO.	REV	SHEET
B	STKNI-72NA-ADA	0	1 OF 1

8 7 6 5 4 3 2 1