

8 7 6 5 4 3 2 1

D

D

C

C

B

B

A

A

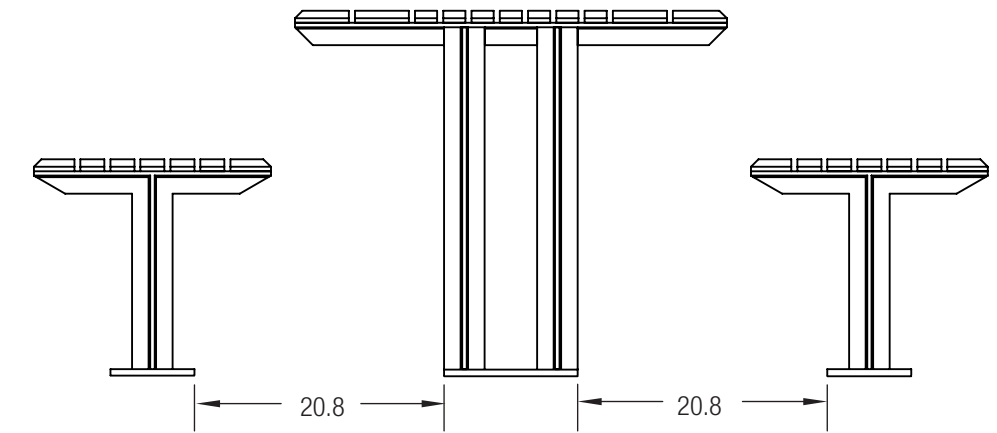
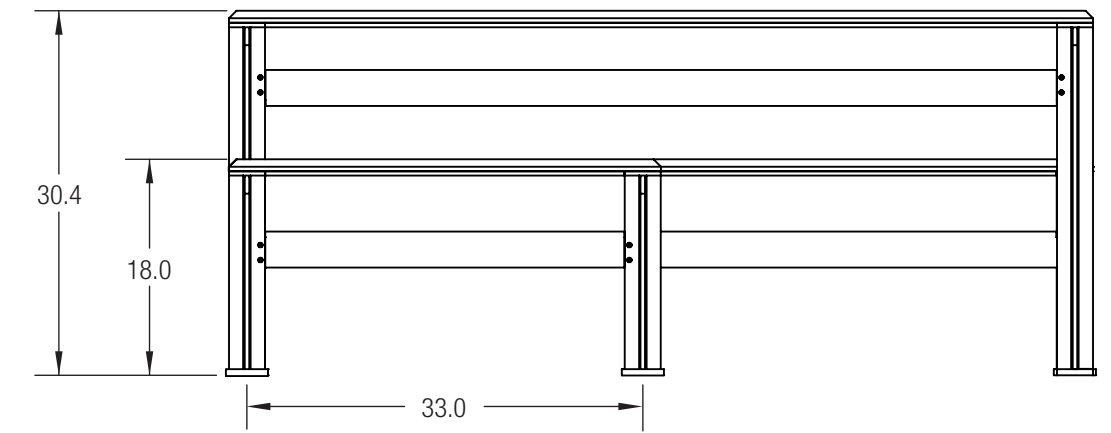
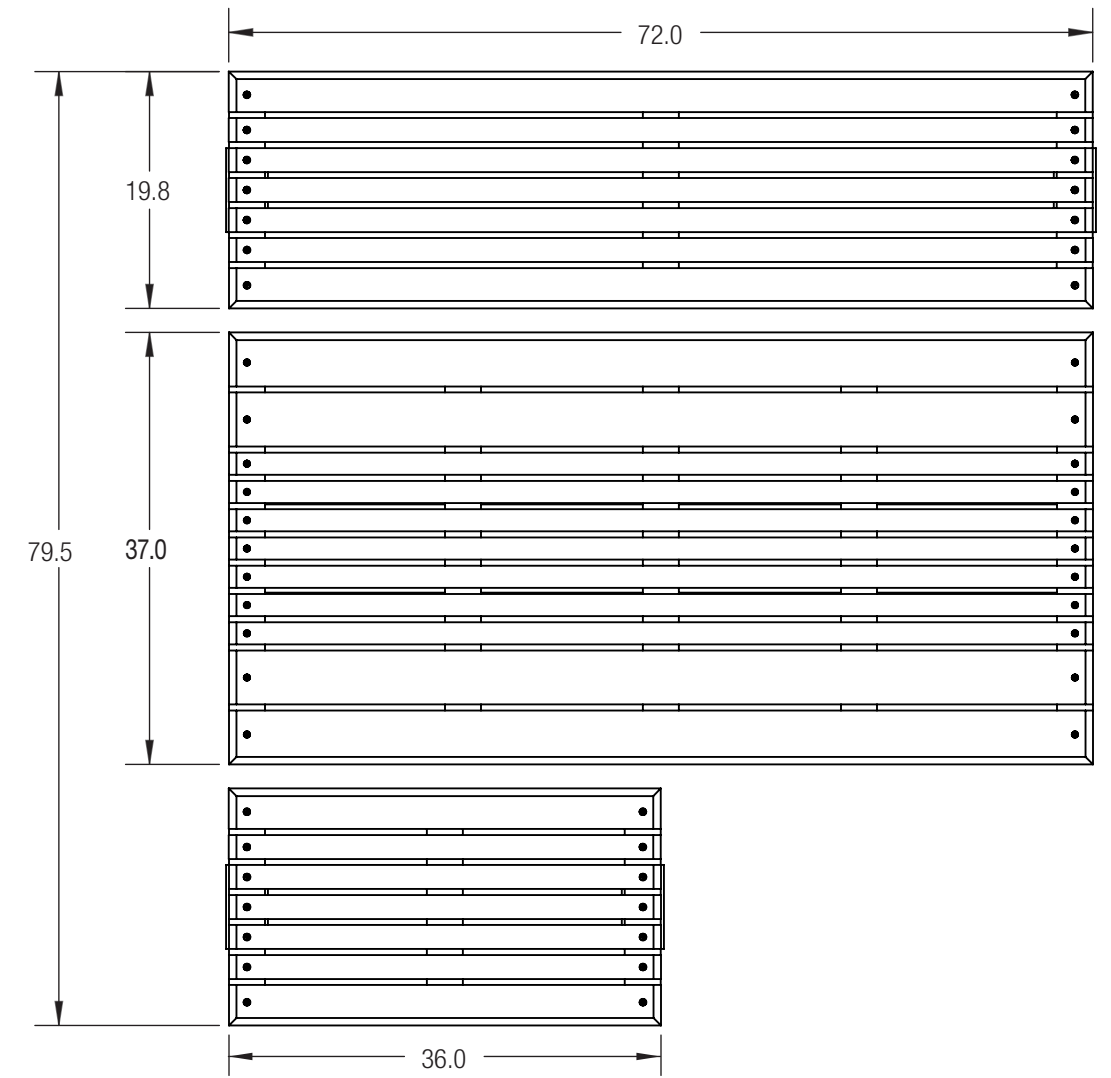

CUSTOMER APPROVAL:

X _____

DATE:

X _____

UNLESS OTHERWISE SPECIFIED,
DIMENSIONS ARE IN INCHES
TOLERANCES (UNLESS OTHERWISE
SPECIFIED):
FRACTIONAL: ±1/32
ANGULAR/BEND: ±1°
TWO PLACE DECIMAL ±.030
THREE PLACE DECIMAL ±.020
MATERIAL: SEE DATA SHEET
FINISH: SEE DATA SHEET
WEIGHT: 300 LBS.
SOURCE: MDW
SCALE: N.T.S.

FORMS+SURFACES® 30 Pine Street, Pittsburgh, PA 15223
Tel (412) 781-9003 Fax (412) 781-7840

	NAME	DATE
DWN	EMK	7/11/2014
DWN	ARS	9/26/2018

KNIGHT TABLE ENSEMBLE,
BACKLESS, ADA OPTION
STKNI-72NW-ADA

SIZE	DWG. NO.	REV	SHEET
B	STKNI-72NW-ADA	0	1 OF 1

8 7 6 5 4 3 2 1

PRINTED: 2/26/2014