

8 7 6 5 4 3 2 1

D

D

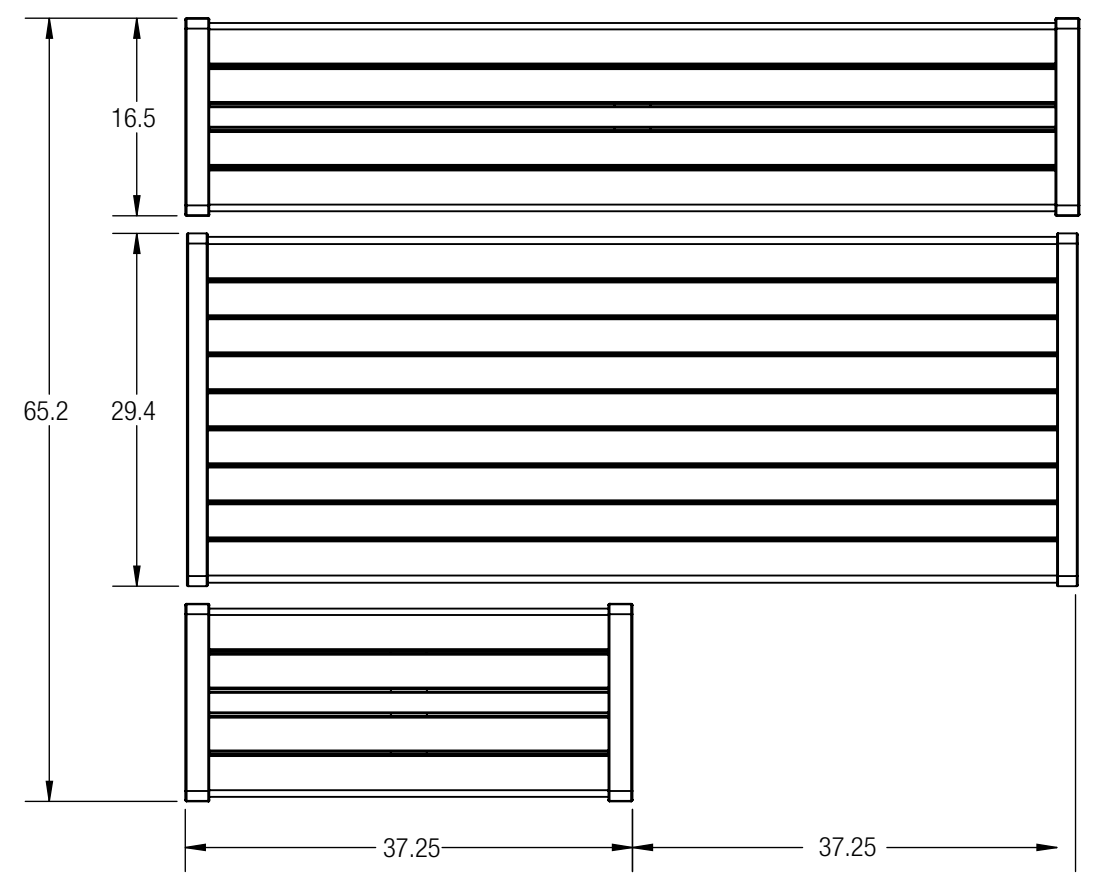

C

C

B

B

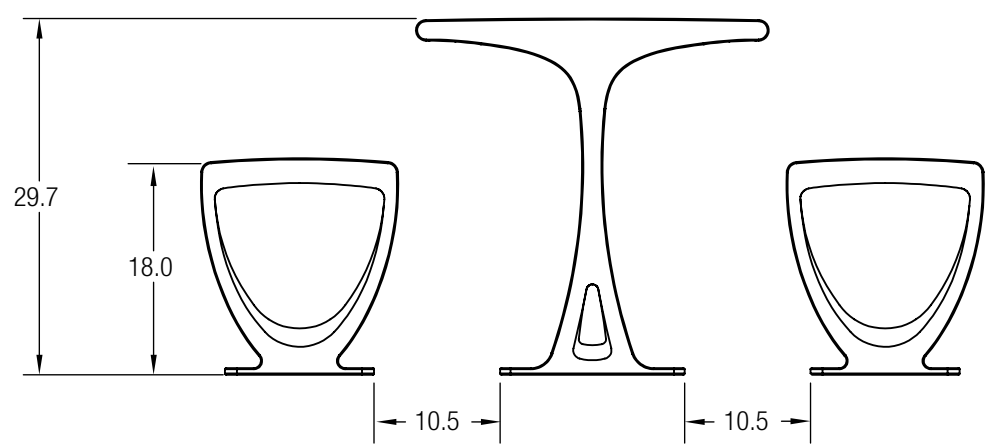
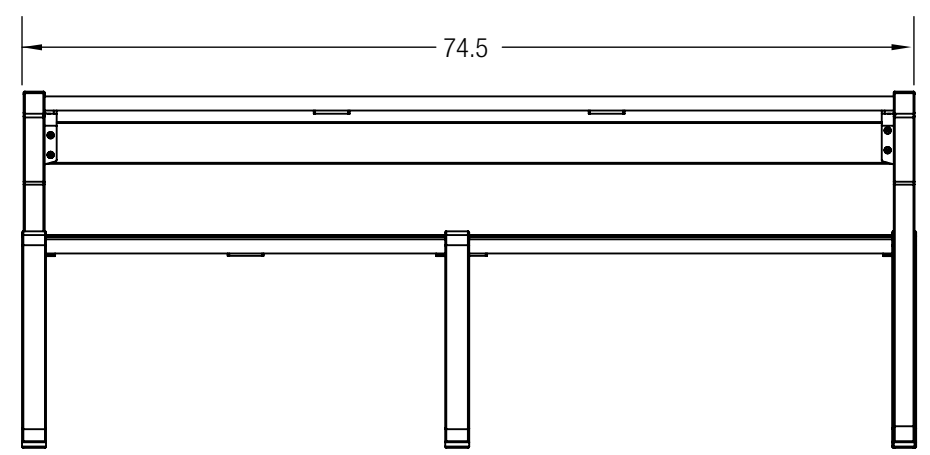

A

A

CUSTOMER APPROVAL:

X \_\_\_\_\_

DATE:

X \_\_\_\_\_

UNLESS OTHERWISE SPECIFIED, DIMENSIONS ARE IN INCHES

**FORMS+SURFACES**® 30 Pine Street, Pittsburgh, PA 15223  
Tel (412) 781-9003 Fax (412) 781-7840

TOLERANCES (UNLESS OTHERWISE SPECIFIED):  
 FRACTIONAL: ±1/32  
 ANGULAR/BEND: ±1°\*  
 TWO PLACE DECIMAL ±.030  
 THREE PLACE DECIMAL ±.020

NAME	DATE
DWN	ASG 7/03/2014

MATERIAL: SEE DATA SHEET

FINISH: SEE DATA SHEET

WEIGHT: 318 LBS.

SOURCE: MDW

SCALE: N.T.S.

DO NOT SCALE DRAWING

PROPRIETARY AND CONFIDENTIAL

THE INFORMATION CONTAINED IN THIS DRAWING IS THE SOLE PROPERTY OF FORMS + SURFACES. ANY REPRODUCTION IN PART OR AS A WHOLE WITHOUT WRITTEN PERMISSION IS PROHIBITED.

SIZE	DWG. NO.	REV	SHEET
B	STTRO-72SC-ADA	0	1 OF 1

TRIO TABLE ENSEMBLE, ADA OPTION  
STTRO-72SC-ADA

8 7 6 5 4 3 2 1

PRINTED: 24-12-2013