

UNLESS OTHERWISE SPECIFIED:				30 Pine Street, Pittsburgh, PA 15223 Tel (412) 781-9003 Fax (412) 781-7840	
1. PRIMARY DIM. ARE IN INCHES & SECONDARY [DIM] IN MM				NAME	
2. TOLERANCES		DWN	RTS	02/09/18	
FRACTIONAL: ±1/32; ANGULAR/BEND: ±1°		CHK		VAYA SIDE TABLE 25X26", VIVIDGLASS TABLE TOP FREESTANDING STVYA-2526L,M-FRS	
TWO PLACE DECIMAL ±.030		THIRD ANGLE PROJECTION			
THREE PLACE DECIMAL ±.020		DO NOT SCALE DRAWING			
3. REMOVE ALL BURRS AND SHARP EDGES		MATERIAL: SEE DATA SHEET		PROPRIETARY AND CONFIDENTIAL	
FINISH: SEE DATA SHEET		WEIGHT: SEE DATA SHEET		THE INFORMATION CONTAINED IN THIS DRAWING IS THE SOLE PROPERTY OF FORMS + SURFACES. ANY REPRODUCTION IN PART OR AS A WHOLE WITHOUT WRITTEN PERMISSION IS PROHIBITED.	
SCALE: NOT TO SCALE		SIZE	DWG. NO.	REV	SHEET
		B	STVYA-2526L,M-FRS	0	1 OF 1

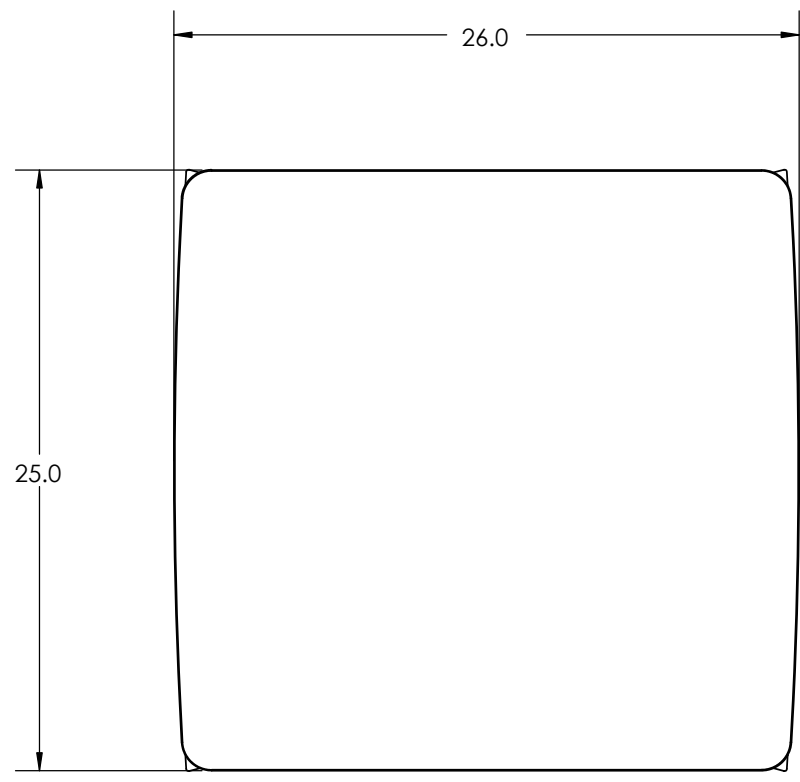

TOP VIEW



SIDE VIEW

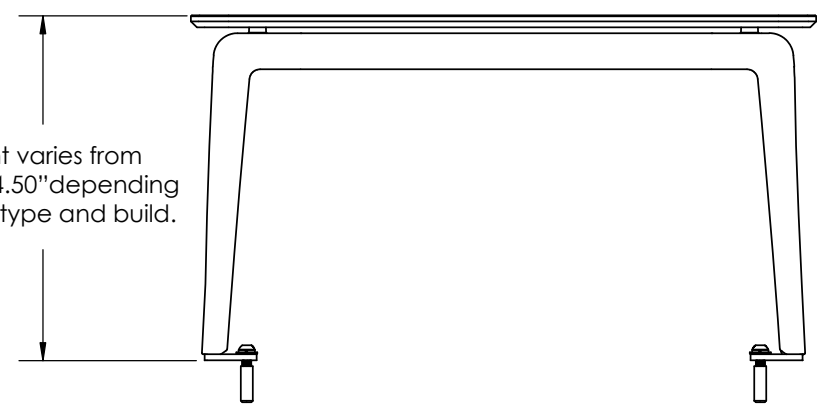

FRONT VIEW

UNLESS OTHERWISE SPECIFIED:		FORMS+SURFACES 30 Pine Street, Pittsburgh, PA 15223 Tel (412) 781-9003 Fax (412) 781-7840			
1. PRIMARY DIM. ARE IN INCHES & SECONDARY [DIM] IN MM				NAME	DATE
2. TOLERANCES		DWN	RTS	02/09/18	
FRACTIONAL: ±1/32; ANGULAR/BEND: ±1°		CHK			
TWO PLACE DECIMAL ±.030		MATERIAL: SEE DATA SHEET DO NOT SCALE DRAWING			
THREE PLACE DECIMAL ±.020		FINISH: SEE DATA SHEET			
3. REMOVE ALL BURRS AND SHARP EDGES		WEIGHT: SEE DATA SHEET			
THIRD ANGLE PROJECTION		SCALE: NOT TO SCALE			
		PROPRIETARY AND CONFIDENTIAL		SIZE	DWG. NO.
		THE INFORMATION CONTAINED IN THIS DRAWING IS THE SOLE PROPERTY OF FORMS + SURFACES. ANY REPRODUCTION IN PART OR AS A WHOLE WITHOUT WRITTEN PERMISSION IS PROHIBITED.		B	STVYA-2526L,M-SFM
				REV	SHEET
				0	1 OF 1

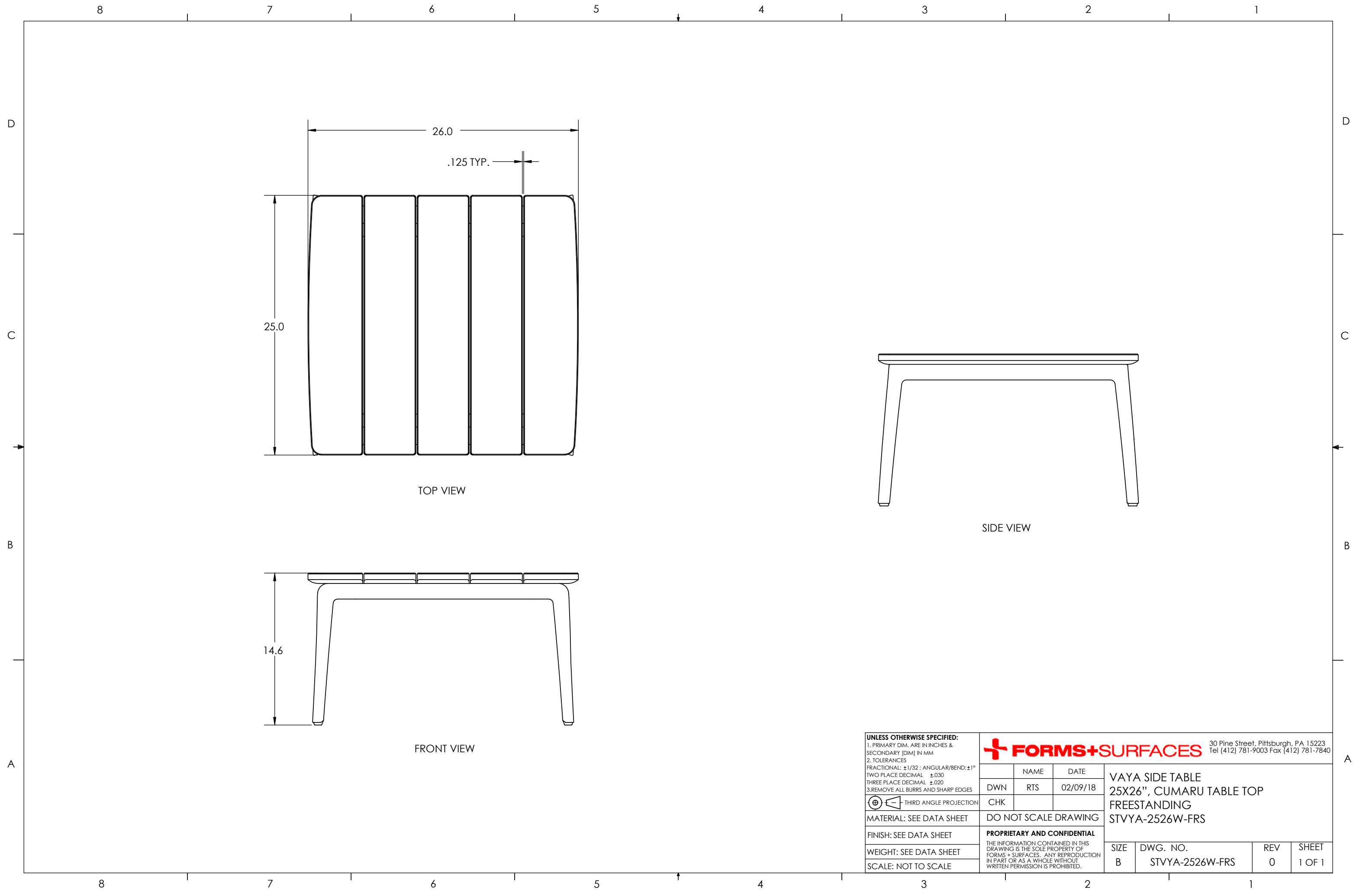

TOP VIEW



SIDE VIEW

FRONT VIEW

UNLESS OTHERWISE SPECIFIED: 1. PRIMARY DIM. ARE IN INCHES & SECONDARY [DIM] IN MM 2. TOLERANCES FRACTIONAL: ±1/32; ANGULAR/BEND: ±1° TWO PLACE DECIMAL ±.030 THREE PLACE DECIMAL ±.020 3. REMOVE ALL BURRS AND SHARP EDGES		FORMS+SURFACES 30 Pine Street, Pittsburgh, PA 15223 Tel (412) 781-9003 Fax (412) 781-7840	
THIRD ANGLE PROJECTION		NAME	DATE
MATERIAL: SEE DATA SHEET		DWN	RTS 02/09/18
FINISH: SEE DATA SHEET		CHK	
WEIGHT: SEE DATA SHEET		DO NOT SCALE DRAWING	
SCALE: NOT TO SCALE		PROPRIETARY AND CONFIDENTIAL THE INFORMATION CONTAINED IN THIS DRAWING IS THE SOLE PROPERTY OF FORMS + SURFACES. ANY REPRODUCTION IN PART OR AS A WHOLE WITHOUT WRITTEN PERMISSION IS PROHIBITED.	
SIZE	DWG. NO.	REV	SHEET
B	STVYA-2526W-FRS	0	1 OF 1

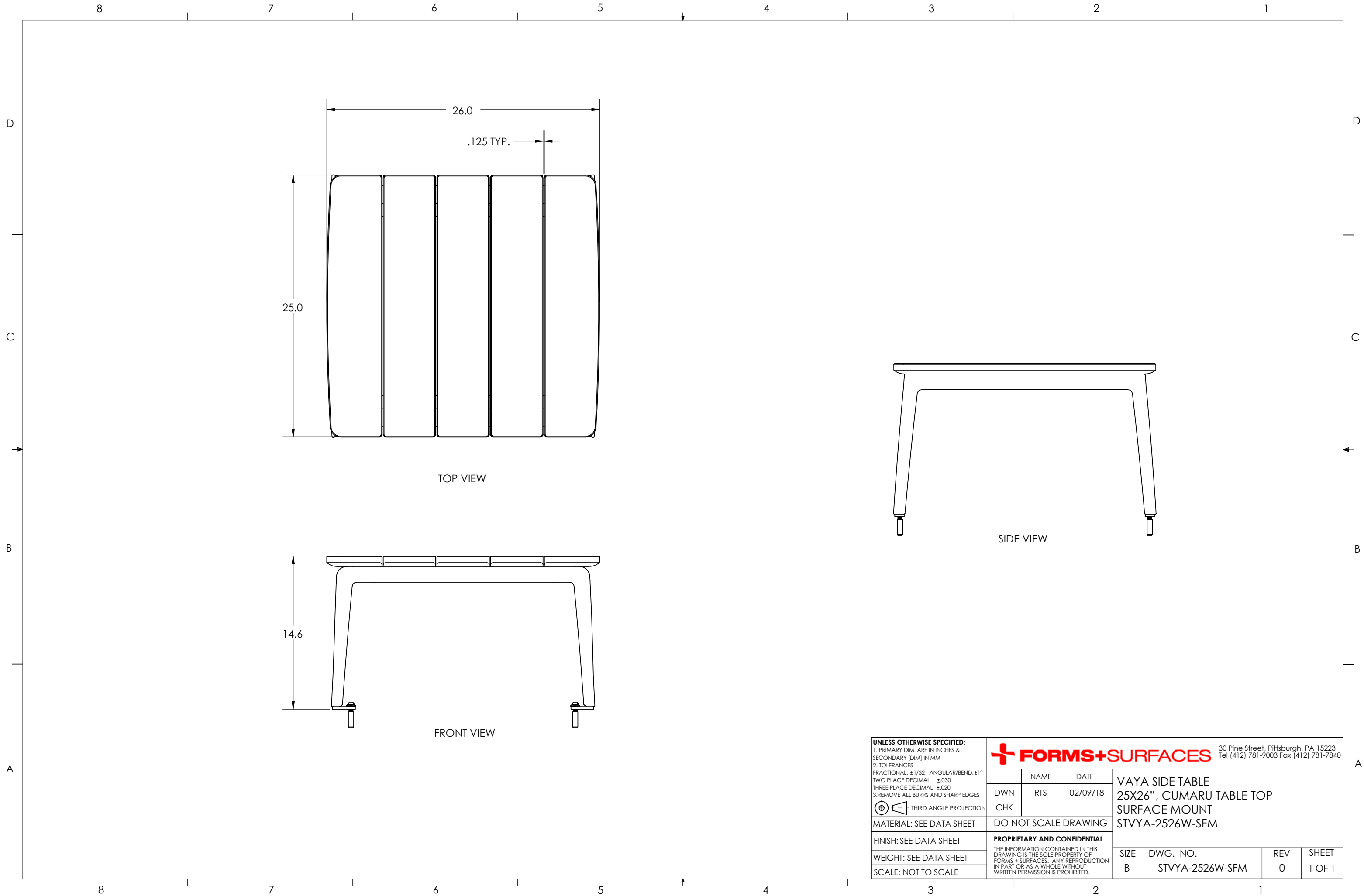
VAYA SIDE TABLE
25X26", CUMARU TABLE TOP
FREESTANDING
STVYA-2526W-FRS



UNLESS OTHERWISE SPECIFIED:		 30 Pine Street, Pittsburgh, PA 15223 Tel (412) 781-9003 Fax (412) 781-7840			
1. PRIMARY DIM. ARE IN INCHES & SECONDARY [DIM] IN MM 2. TOLERANCES FRACTIONAL: ±1/32; ANGULAR/BEND: ±1° TWO PLACE DECIMAL ±.030 THREE PLACE DECIMAL ±.020 3. REMOVE ALL BURRS AND SHARP EDGES					
 THIRD ANGLE PROJECTION		NAME	DATE	VAYA SIDE TABLE 25X26", CUMARU TABLE TOP SURFACE MOUNT STVYA-2526W-SFM	
MATERIAL: SEE DATA SHEET		DWN	RTS		
FINISH: SEE DATA SHEET		CHK		DO NOT SCALE DRAWING	
WEIGHT: SEE DATA SHEET		PROPRIETARY AND CONFIDENTIAL <small>THE INFORMATION CONTAINED IN THIS DRAWING IS THE SOLE PROPERTY OF FORMS + SURFACES. ANY REPRODUCTION IN PART OR AS A WHOLE WITHOUT WRITTEN PERMISSION IS PROHIBITED.</small>			
SCALE: NOT TO SCALE		SIZE	DWG. NO.		REV
		B	STVYA-2526W-SFM	0	1 OF 1